



US009003510B2

(12) **United States Patent**
Ellis

(10) **Patent No.:** **US 9,003,510 B2**
(45) **Date of Patent:** ***Apr. 7, 2015**

(54) **COMPUTER OR MICROCHIP WITH A SECURE SYSTEM BIOS HAVING A SEPARATE PRIVATE NETWORK CONNECTION TO A SEPARATE PRIVATE NETWORK**

(56) **References Cited**

U.S. PATENT DOCUMENTS

3,539,876 A 11/1970 Feinberg et al.
3,835,530 A 9/1974 Kilby

(Continued)

FOREIGN PATENT DOCUMENTS

DE 40 08 335 9/1991
EP 0 647 052 4/1995

(Continued)

OTHER PUBLICATIONS

Lampson, Butler. "Accountability and freedom." Cambridge Computer Seminar, Cambridge, UK. 2005.*

(Continued)

(71) Applicant: **Frampton E. Ellis**, Jasper, FL (US)

(72) Inventor: **Frampton E. Ellis**, Jasper, FL (US)

(*) Notice: Subject to any disclaimer, the term of this patent is extended or adjusted under 35 U.S.C. 154(b) by 0 days.

This patent is subject to a terminal disclaimer.

(21) Appl. No.: **14/334,283**

(22) Filed: **Jul. 17, 2014**

(65) **Prior Publication Data**

US 2014/0331307 A1 Nov. 6, 2014

Related U.S. Application Data

(63) Continuation of application No. 13/815,814, filed on Mar. 15, 2013, now Pat. No. 8,898,768, which is a continuation of application No. 13/398,403, filed on Feb. 16, 2012, now Pat. No. 8,429,735, and a

(Continued)

(51) **Int. Cl.**

G06F 15/173 (2006.01)
G06F 13/40 (2006.01)

(Continued)

(52) **U.S. Cl.**

CPC **H04L 63/02** (2013.01); **G06F 11/2043** (2013.01); **G06F 21/71** (2013.01); **G06F 21/50** (2013.01); **G06F 21/85** (2013.01); **H04L 63/0209** (2013.01)

(58) **Field of Classification Search**

CPC H04L 63/02; H04L 63/0209; G06F 21/85; G06F 21/50; G06F 11/2043; G06F 21/71

USPC 726/11, 22, 30; 713/153, 154, 194

See application file for complete search history.

Primary Examiner — Michael Simitoski

(74) *Attorney, Agent, or Firm* — Mendelsohn, Drucker & Dunleavy, P.C.

(57) **ABSTRACT**

A computer or microchip including a network connection for connection to a public network of computers including the Internet, the network connection being located in a public unit; and an additional and separate network connection for connection to a separate, private network of computers, the additional network connection being located in a protected private unit. An inner hardware-based access barrier or firewall is located between and communicatively connects the protected private unit and the public unit; and the private and public units and the two separate network connections are separated by the inner barrier or firewall. The protected private unit includes at least a first microprocessor and a system BIOS located in flash memory. The public unit includes at least a second or many microprocessors separate from the inner barrier or firewall. The inner barrier or firewall comprises a bus with an on/off switch controlling communication input and output.

35 Claims, 22 Drawing Sheets

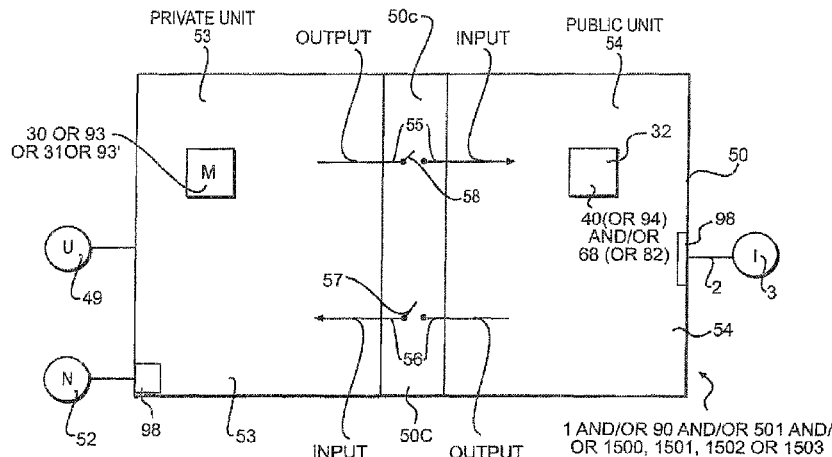

Related U.S. Application Data

- continuation-in-part of application No. 13/014,201, filed on Jan. 26, 2011, now abandoned, said application No. 13/398,403 is a continuation-in-part of application No. 13/016,527, filed on Jan. 28, 2011, now Pat. No. 8,171,537, and a continuation-in-part of application No. PCT/US2011/023028, filed on Jan. 28, 2011, and a continuation-in-part of application No. PCT/US2011/025257, filed on Feb. 17, 2011.
- (60) Provisional application No. 61/457,297, filed on Feb. 18, 2011, provisional application No. 61/457,976, filed on Jul. 26, 2011, provisional application No. 61/457,983, filed on Jul. 28, 2011, provisional application No. 61/573,006, filed on Aug. 2, 2011, provisional application No. 61/573,007, filed on Aug. 3, 2011, provisional application No. 61/282,337, filed on Jan. 26, 2010, provisional application No. 61/282,378, filed on Jan. 29, 2010, provisional application No. 61/282,478, filed on Feb. 17, 2010, provisional application No. 61/282,503, filed on Feb. 22, 2010, provisional application No. 61/282,861, filed on Apr. 12, 2010, provisional application No. 61/344,018, filed on May 7, 2010, provisional application No. 61/457,184, filed on Jan. 24, 2011.
- (51) **Int. Cl.**
H04L 29/06 (2006.01)
G06F 11/20 (2006.01)
G06F 21/71 (2013.01)
G06F 21/50 (2013.01)
G06F 21/85 (2013.01)
G06F 17/00 (2006.01)

(56) References Cited

U.S. PATENT DOCUMENTS

4,245,306	A	1/1981	Besemer et al.	5,349,682	A	9/1994	Rosenberry
4,276,594	A	6/1981	Morley	5,357,404	A	10/1994	Bright et al.
4,278,837	A	7/1981	Best	5,357,632	A	10/1994	Pian et al.
4,467,400	A	8/1984	Stopper	5,361,362	A	11/1994	Benkeser et al.
4,489,397	A	12/1984	Lee	5,381,534	A	1/1995	Shi
4,703,436	A	10/1987	Varshney	5,388,211	A	2/1995	Hornbuckle
4,736,317	A	4/1988	Hu et al.	5,392,400	A	2/1995	Berkowitz et al.
4,747,139	A	5/1988	Taaffe	5,410,651	A	4/1995	Sekizawa et al.
4,827,508	A	5/1989	Shear	5,426,741	A	6/1995	Butts, Jr. et al.
4,855,903	A	8/1989	Carleton et al.	5,428,783	A	6/1995	Lake
4,882,752	A	11/1989	Lindman et al.	5,434,998	A	7/1995	Akai
4,893,174	A	1/1990	Yamada et al.	5,446,843	A	8/1995	Fucito et al.
4,907,228	A	3/1990	Bruckert et al.	5,457,797	A	10/1995	Butterworth et al.
4,918,596	A	4/1990	Nakano	5,475,606	A	12/1995	Muyshondt et al.
4,969,092	A	11/1990	Shorter	5,497,465	A	3/1996	Chin et al.
5,025,369	A	6/1991	Schwartz	5,515,511	A	5/1996	Nguyen et al.
5,031,089	A	7/1991	Liu et al.	5,522,070	A	5/1996	Sumimoto
5,068,780	A	11/1991	Bruckert et al.	5,530,949	A	6/1996	Koda
5,103,393	A	4/1992	Harris et al.	5,535,408	A	7/1996	Hillis
5,109,329	A	4/1992	Strelhoff	5,546,594	A	8/1996	Wazumi
5,109,512	A	4/1992	Bahr et al.	5,550,984	A	8/1996	Gelb
5,136,708	A	8/1992	LaPourtre et al.	5,568,375	A	10/1996	Rausch
5,155,808	A	10/1992	Shimizu	5,570,270	A	10/1996	Naedel et al.
5,195,031	A	3/1993	Ordish	5,572,643	A	11/1996	Judson
5,212,780	A	5/1993	Padgaonkar et al.	5,576,554	A	11/1996	Hsu
5,214,657	A	5/1993	Farnworth et al.	5,586,121	A	12/1996	Moura et al.
5,237,507	A	8/1993	Chasek	5,587,928	A	12/1996	Jones et al.
5,260,943	A	11/1993	Comroe et al.	5,588,003	A	12/1996	Ohba et al.
5,282,272	A	1/1994	Guy et al.	5,590,284	A	12/1996	Crosetto
5,283,819	A	2/1994	Glick et al.	5,592,376	A	1/1997	Hodroff
5,291,494	A	3/1994	Bruckert et al.	5,592,632	A	1/1997	Leung et al.
5,291,502	A	3/1994	Pezeshki et al.	5,594,491	A	1/1997	Hodge et al.
5,291,505	A	3/1994	Nielsen	5,600,597	A	2/1997	Kean et al.
5,341,477	A	8/1994	Pitkin et al.	5,604,882	A	2/1997	Hoover et al.
				5,606,615	A	2/1997	Lapointe et al.
				5,608,448	A	3/1997	Smoral et al.
				5,615,127	A	3/1997	Beatty et al.
				5,627,879	A	5/1997	Russell et al.
				5,666,484	A	9/1997	Orimo et al.
				5,678,028	A	10/1997	Bershteyn et al.
				5,680,461	A	10/1997	McManis
				5,680,548	A	10/1997	Trugman
				5,696,902	A	12/1997	Leclercq et al.
				5,699,528	A	12/1997	Hogan
				5,701,507	A	12/1997	Bonneau, Jr. et al.
				5,710,884	A	1/1998	Dedrick
				5,734,913	A	3/1998	Iwamura et al.
				5,748,489	A	5/1998	Beatty et al.
				5,752,067	A	5/1998	Wilkinson et al.
				5,754,766	A	5/1998	Shaw et al.
				5,758,077	A	5/1998	Danahy et al.
				5,758,345	A	5/1998	Wang
				5,761,507	A	6/1998	Govett
				5,764,889	A	6/1998	Ault et al.
				5,774,337	A	6/1998	Lee et al.
				5,774,668	A	6/1998	Choquier et al.
				5,774,721	A	6/1998	Robinson
				5,784,551	A	7/1998	De Leva et al.
				5,784,628	A	7/1998	Reneris
				5,790,431	A	8/1998	Ahrens, Jr. et al.
				5,793,968	A	8/1998	Gregerson et al.
				5,794,059	A	8/1998	Barker et al.
				5,802,320	A	9/1998	Baehr et al.
				5,809,190	A	9/1998	Chen
				5,815,665	A	9/1998	Teper et al.
				5,815,793	A	9/1998	Ferguson
				5,826,014	A	10/1998	Coley et al.
				5,826,029	A	10/1998	Gore
				5,828,833	A	10/1998	Belville et al.
				5,835,726	A	11/1998	Shwed et al.
				5,838,436	A	11/1998	Hotaling et al.
				5,838,542	A	11/1998	Nelson et al.
				5,843,799	A	12/1998	Hsu et al.
				5,844,594	A	12/1998	Ferguson
				5,845,074	A	12/1998	Kobata
				5,850,449	A	12/1998	McManis
				5,861,817	A	1/1999	Palmer et al.
				5,862,357	A	1/1999	Hagersten et al.
				5,864,738	A	1/1999	Kessler et al.

(56)

References Cited

U.S. PATENT DOCUMENTS

5,870,721 A 2/1999 Norris
 5,872,987 A 2/1999 Wade et al.
 5,881,284 A 3/1999 Kubo
 5,889,989 A 3/1999 Robertazzi et al.
 5,896,499 A 4/1999 McKelvey
 5,905,429 A 5/1999 Hornstein et al.
 5,909,052 A 6/1999 Ohta et al.
 5,909,681 A 6/1999 Passera et al.
 5,917,629 A 6/1999 Hortensius et al.
 5,919,247 A 7/1999 Van Hoff et al.
 5,930,511 A 7/1999 Hinsley
 5,940,516 A 8/1999 Mason et al.
 5,943,421 A 8/1999 Grabon
 5,964,832 A 10/1999 Kisor
 5,978,829 A 11/1999 Chung et al.
 6,003,133 A 12/1999 Moughanni et al.
 6,026,502 A 2/2000 Wakayama
 6,052,555 A 4/2000 Ferguson
 6,065,118 A 5/2000 Bull et al.
 6,067,082 A 5/2000 Enmei
 6,073,209 A 6/2000 Bergsten
 6,078,733 A 6/2000 Osborne
 6,093,933 A 7/2000 Farnworth et al.
 6,098,091 A 8/2000 Kisor
 6,108,787 A 8/2000 Anderson et al.
 6,112,225 A 8/2000 Kraft et al.
 6,112,243 A 8/2000 Downs et al.
 6,115,698 A 9/2000 Tuck et al.
 6,115,819 A 9/2000 Anderson
 6,167,428 A 12/2000 Ellis
 6,202,153 B1 3/2001 Diamant et al.
 6,208,634 B1 3/2001 Boulos et al.
 6,219,627 B1 4/2001 Bonneau et al.
 6,268,788 B1 7/2001 Gray
 6,272,533 B1 8/2001 Browne
 6,287,949 B1 9/2001 Mori et al.
 6,326,245 B1 12/2001 Farnworth et al.
 6,366,472 B2 4/2002 Alina et al.
 6,440,775 B2 8/2002 Khoury
 6,487,664 B1 11/2002 Kellum
 6,578,089 B1 6/2003 Simpson et al.
 6,578,140 B1 6/2003 Policard
 6,645,832 B2 11/2003 Kim et al.
 6,701,432 B1 3/2004 Deng et al.
 6,715,084 B2 3/2004 Aaron et al.
 6,725,250 B1 4/2004 Ellis
 6,732,141 B2 5/2004 Ellis
 6,772,347 B1 8/2004 Xie et al.
 6,797,545 B2 9/2004 Farnworth et al.
 6,865,672 B1 3/2005 Carmeli
 6,950,947 B1 9/2005 Purtell et al.
 7,024,449 B1 4/2006 Ellis
 7,035,906 B1 4/2006 Ellis
 7,047,275 B1 5/2006 Ellis
 7,148,565 B2 12/2006 Kim et al.
 7,161,175 B2 1/2007 Shau
 7,406,583 B2 7/2008 Warriier et al.
 7,412,588 B2 8/2008 Georgiou et al.
 7,467,406 B2 12/2008 Cox et al.
 7,484,247 B2 1/2009 Rozman et al.
 7,506,020 B2 3/2009 Ellis
 7,562,211 B2 7/2009 Paya et al.
 7,606,854 B2 10/2009 Ellis
 7,634,529 B2 12/2009 Ellis
 7,675,867 B1 3/2010 Mraz et al.
 7,761,605 B1 7/2010 Rothwell et al.
 7,805,756 B2 9/2010 Ellis
 7,814,233 B2 10/2010 Ellis
 7,840,997 B2 11/2010 Shevchenko
 7,908,650 B2 3/2011 Ellis
 7,926,097 B2 4/2011 Ellis
 7,984,301 B2 7/2011 Kaabouch et al.
 8,010,789 B2 8/2011 Witchey
 8,068,415 B2 11/2011 Mraz
 8,125,796 B2 2/2012 Ellis

8,164,170 B2 4/2012 Ellis
 8,171,537 B2 5/2012 Ellis
 8,209,373 B2 6/2012 Ellis
 8,255,986 B2 8/2012 Ellis
 8,291,485 B2 10/2012 Ellis, III
 8,312,529 B2 11/2012 Ellis
 8,327,038 B2 12/2012 Alcouffe et al.
 8,378,474 B2 2/2013 Ellis
 8,429,735 B2 4/2013 Ellis
 8,474,033 B2 6/2013 Ellis
 8,677,026 B2 3/2014 Ellis, III
 2001/0046119 A1 11/2001 Hamano et al.
 2001/0054159 A1 12/2001 Hoshino
 2004/0073603 A1 4/2004 Ellis
 2004/0098621 A1 5/2004 Raymond
 2004/0158744 A1 8/2004 Deng et al.
 2004/0162992 A1 8/2004 Sami et al.
 2004/0215931 A1 10/2004 Ellis
 2004/0236874 A1 11/2004 Largman et al.
 2005/0138169 A1 6/2005 Bahr
 2005/0180095 A1 8/2005 Ellis
 2006/0004912 A1 1/2006 Najam et al.
 2006/0031940 A1 2/2006 Rozman et al.
 2006/0075001 A1 4/2006 Canning et al.
 2006/0095497 A1 5/2006 Ellis
 2006/0177226 A1 8/2006 Ellis
 2006/0190565 A1 8/2006 Ellis
 2006/0248749 A1 11/2006 Ellis
 2007/0127500 A1 6/2007 Maeng
 2007/0162955 A1* 7/2007 Zimmer et al. 726/2
 2007/0162974 A1 7/2007 Speidel
 2007/0196948 A1 8/2007 Trezza
 2007/0261112 A1 11/2007 Todd et al.
 2007/0300305 A1 12/2007 Gonsalves et al.
 2008/0052505 A1 2/2008 Theobald
 2008/0083976 A1 4/2008 Haba et al.
 2008/0134290 A1 6/2008 Olsson
 2008/0271122 A1 10/2008 Nolan et al.
 2009/0006834 A1* 1/2009 Rothman et al. 713/2
 2009/0026524 A1 1/2009 Kreupl et al.
 2009/0031412 A1 1/2009 Ellis
 2009/0165139 A1 6/2009 Yerazunis et al.
 2009/0200661 A1 8/2009 Ellis
 2009/0204831 A1 8/2009 Cousson et al.
 2009/0254986 A1 10/2009 Harris et al.
 2009/0282092 A1 11/2009 Ellis
 2010/0005531 A1 1/2010 Largman et al.
 2010/0011083 A1 1/2010 Ellis
 2010/0131729 A1 5/2010 Fulcheri et al.
 2011/0004930 A1 1/2011 Ellis
 2011/0004931 A1 1/2011 Ellis
 2011/0225645 A1 9/2011 Ellis
 2012/0003658 A1 1/2012 Davies et al.
 2012/0036581 A1* 2/2012 Maximilien et al. 726/26
 2012/0096537 A1 4/2012 Ellis
 2012/0155002 A1 6/2012 Ellis
 2012/0175752 A1 7/2012 Ellis

FOREIGN PATENT DOCUMENTS

EP 0 840216 5/1998
 EP 0 853 279 7/1998
 EP 1164766 A2 12/2001
 EP 1 164 766 12/2011
 WO WO 94/01964 1/1994
 WO WO 95/01060 1/1995
 WO WO 98/26366 6/1998
 WO WO 99/04561 1/1999
 WO WO 99/32972 7/1999
 WO WO 2011/094616 8/2011
 WO WO 2011/103299 8/2011
 WO WO2011094616 A1 8/2011
 WO WO2011103299 A1 8/2011
 WO WO2012112794 A1 8/2012

OTHER PUBLICATIONS

Vasudevan, Amit, et al. "Lockdown: A safe and practical environment for security applications." CMU-CyLab-09-011 (2009).*

(56)

References Cited

OTHER PUBLICATIONS

- File History of U.S. Appl. No. 11/329,423.
 File History of U.S. Appl. No. 12/164,661.
 File History of U.S. Appl. No. 12/822,928.
 File History of U.S. Appl. No. 12/829,120.
 File History of U.S. Appl. No. 13/016,149 from Jul. 23, 2013 to present.
 File History of U.S. Appl. No. 13/018,089 from Jul. 24, 2013 to present.
 Complete file history for U.S. Appl. No. 13/783,351.
 Complete file history for U.S. Appl. No. 14/174,693.
 Complete file history for U.S. Appl. No. 14/092,707.
 Complete file history for U.S. Appl. No. 12/364,745.
 Complete file history for U.S. Appl. No. 12/499,555.
 Complete file history for U.S. Appl. No. 13/240,842 from Aug. 30, 2013 to present.
 Complete file history for U.S. Appl. No. 13/283,274.
 Complete file history for U.S. Appl. No. 13/495,867 from Aug. 7, 2013 to present.
 Complete file history for U.S. Appl. No. 13/594,614.
 Complete file history for U.S. Appl. No. 13/599,484 from Aug. 1, 2013 to present.
 Complete file history for U.S. Appl. No. 13/404,888 from Aug. 30, 2013 to present.
 Complete file history for U.S. Appl. No. 09/884,041.
 Complete file history for U.S. Appl. No. 11/196,527.
 Complete file history for U.S. Appl. No. 09/315,026.
 Complete file history for U.S. Appl. No. 09/571,558.
 Complete file history for U.S. Appl. No. 10/684,657.
 Complete file history for U.S. Appl. No. 10/802,049.
 Complete file history for U.S. Appl. No. 09/085,755.
 Complete file history for U.S. Appl. No. 08/980,058.
 Complete file history for U.S. Appl. No. 09/935,779.
 Complete file history for U.S. Appl. No. 09/669,730.
 Complete file history for U.S. Appl. No. 11/338,887.
 Complete file history for U.S. Appl. No. 09/320,660.
 Complete file history for U.S. Appl. No. 09/213,875.
 Complete file history for U.S. Appl. No. 10/663,911.
 Complete file history for U.S. Appl. No. 13/180,164.
 Complete file history for U.S. Appl. No. 12/292,769.
 Complete file history for U.S. Appl. No. 12/292,553.
 Complete file history for U.S. Appl. No. 13/426,133.
 Complete file history for U.S. Appl. No. 13/398,403.
 Complete file history for U.S. Appl. No. 13/768,582.
 Complete file history for U.S. Appl. No. 14/230,713.
 Complete file history for U.S. Appl. No. 13/815,814.
 Complete file history for U.S. Appl. No. 14/328,587.
 Complete file history for U.S. Appl. No. 14/333,759.
 Famatech, Redmin v3.0, User Manual, 2007.
 Connect One. "iChip CO2064/CO2144 Data Sheet Ver. 1.20", 2011.
 Shao, Fengjing et al., "A New Secure Architecture of Network computer Based on Single CPU and Dual Bus", Fifth IEEE International Symposium on Embedded Computing, 2008.
 Wang, Tiedong et al. "A Hardware Implement of bus Bridge Based on single CPU and Dual Bus", 2008 International Symposium on computer Science and Computational Technology, 2008.
 International Search Report and Written Opinion; Mailed May 4, 2012 for corresponding International Application No. PCT/US2012/025481.
 Fengjing Shao et al., "a new secure architecture of network computer based on single CPU and Dual Bus" Fifth IEEE International Symposium on Embedded Computing, pp. 309-314 (2008).
 Tiedong Wang et al., "A Hardware implement of Bus Bridge Based on Single CPU and Dual Bus", 2008 International Symposium on Computer Science and Computational Technology, pp. 17-20 (2008).
 Farnatech "Radmin V3.0, User Manual", Jun. 3, 2007 (203 pages).
 Connect One, iChip CO2064/CO2128/CO2144, 2011 (64 pages).
 O. M. Woodward et al., "The Omniguide Antenna; An Omnidirectional Waveguide Array for UHF-TV Broadcasts", IRE International Convention Records, pp. 37-39, Mar. 1955.
 Litzkow, et al., "Condor—A Hunter of Idle Workstations", 1988 IEEE, pp. 104-111.
 Theimer, et al., "Finding Idle Machines in a Workstation-Based Distributed System", IEEE Transactions on Software Engineering, Nov. 1989, vol. 15, No. 11, pp. 1444-1458.
 Brown et al., Special Edition Using Netscape TM 2 Second Edition, Que Corporation, 1995, Ch. 1-2.
 Gilder, "Angst and Awe on the Internet by George Gilder", Forbes ASAP, Dec. 4, 1995.
 Tanduary, et al., "Batrun: Utilizing Idle Workstations for Large-scale Computing", Summer 1996, pp. 41-48.
 Brisbin, "Shopping for Internet Access" MacUser, Dec. 1994, v.10, p. 133(2).
 Gilder, "The Bandwidth Tidal Wave", Forbes ASAP, Dec. 5, 1994.
 N/A, "Special Report—Wonder Chips", Business Week, Jul. 4, 1994.
 N/A, "Supercomputers Divide and Conquer", The Economist, Dec. 14, 1996.
 N/A, "Cyber View World Widgets", Scientific American, May 1997, p. 48.
 Gibbs, "Bandwidth, Unlimited", Scientific American, Jan. 1997, p. 41.
 Markoff, "A New Standard to Govern PC's with Multiple Chips, Work Stations Mimicking Supercomputers", The New York Times, Oct. 28, 1997.
 N/A, "Aliens on your desktop", The Economist, Apr. 18, 1998, p. 78.
 Hare et al., "Master the Complexities of Network Security", Internet Firewalls and Network Security, Second Edition, pp. 325-350 and 516, 1996.
 Fox et al., Petaops and Exaops: Supercomputing on the Web, "IEEE Internet Computing", vol. 1 No. 2 Mar.-Apr. 1997, pp. 38-46.
 Dincer et al., Building a World-Wide Virtual Machine Based on Web and HPCC Technologies, "Student Technical Papers", <http://www.supercomp.org/sc96/proceedings/SC96PROC/DINCER/INDEX.HTM>, pp. 1-18 (1996).
 Hobbs et al., A Remote Process Creation and Execution Facility Supporting Parallel Execution on Distributed Systems, "IEEE 1996", pp. 92-99.
 Boku et al., The Architecture of Massively Parallel Processor CP-PACS, "IEEE 1997", pp. 31-40.
 Choi et al., A Diagnostic Network for Massively Parallel Processing Systems, "IEEE 1994", pp. 348-353.
 Bellovin et al., Network Firewalls, "IEEE Communications Magazine 1994", pp. 50-57.
 Weiyi et al., "Java-to-Go—Iterative Computing Using Java", Sep. 10, 1996 <http://ptolemy.eecs.berkeley.edu/dgm/javatools/java-to-go/>.
 Sullivan et al., "A New Major SETI Project Based on Project Serendip Data and 100,000 Personal Computers", <http://setiathome.ss/berkeley.edu/woody-paper.htm/>; (1997).
 "Ein-Chip-Firewall", ElektronikNet Top News, XP-002164257; Mar. 31, 1999.
 "Means for Implementing Optical Interconnections for Parallel Processors", IBM Technical Disclosure Bulletin, Apr. 1991, vol. 33, No. 11, pp. 56-58, XP 000110310.
 Alexandrov et al., "SuperWeb; Research Issues in Java-Based Global Computing", Concurrency, vol. 9, No. 6, Jun. 1997, pp. 535-553.
 Baratloo et al., "Charlotte: Metacomputing on the Web", 9th International Conference on Parallel and Distributed Computing Systems (PDCS), 1996, pp. 1-8.
 Bevinakoppa et al., "Digital Image Compression on a Network of Transputers", Proc. of 5th Australian Transputer & OCCAM User Group Conference, IOS Press, Amsterdam, pp. 25-32; Nov. 4, 1992.
 Blumofe, R. et al., "Scheduling Large-Scale Parallel Computations on Networks of Workstations", Proc. Of the 3rd IEEE Int'l Sump on High Performance Distributed Computing, pp. 96-105, Aug. 1994.
 Fields, Scott, "Hunting for Wasted Computing Power—New Software for Computing Networks Plus Idle PC's to Work", 1993 University of Wisconsin—Madison. Internet: <http://www.cs.wisc.edu/condor/doc/Wiseidea.html>.
 Brecht et al., "ParaWeb: Towards World-Wide Supercomputing", Proceedings of the Seventh AcM SIGOPS European Workshop, Sep. 1996, 8 pgs.

(56)

References Cited

OTHER PUBLICATIONS

- Capello et al., "Market-Based Massively Parallel Internet Computing", Proceedings Third Working Conference on Massively Parallel Programming Models, 1998, pp. 118-129.
- Celenk, M. et al., "Parallel Task Execution in LANs and Performance Analysis", Proc. Of the 1995 IEEE 14th Annual Int'l Phoenix Conf. on Computers and Communications, pp. 423-429, Mar. 1995.
- Chen, C. et al., "The DBC: Processing Scientific Data Over the Internet", Proc. Of the 16th Int'l Conf. on Distributed Computing Systems, pp. 673-679, May 1996.
- Clark, H. et al., "DAWGS—A Distributed Computer Server Utilizing Idle Workstations", Proc. Of the 5th Distributed Memory Computing Conf., IEEE, pp. 732-741, Apr. 1990.
- Fogg, C., "Survey of Software and Hardware VLC Architectures", SPIE, vol. 2186, Image and Video Compression (1994), pp. 29-37.
- Fox et al., "Towards Web/Java based High Performance Distributed Computing—an Evolving Virtual Machine", as presented at 5th IEEE Int'l Symposium on High Performance Distributed Computing, Aug. 6-9, 1996, 86 pages.
- Fox, E., "Advances in Interactive Digital Multimedia Systems", Computer, Oct. 1991, pp. 9-21.
- Gemmell, et al., "Multimedia Storage Servers: a Tutorial", Computer, May 1995, pp. 40-49.
- Hayes "Computing Science; Collective Wisdom" American Scientist, Mar.-Apr. 1998, pp. 1-8.
- Kim, B. "ATM Network: Goals and Challenges", Communications of the ACM, Feb. 1995, vol. 38, No. 2, pp. 39-44, 109.
- Kremien, O., "Buying and Selling Computational Power Over the Network", Proc. Of the 4th Int'l Conf. on Computer Communications and Networks, IEEE, pp. 616-619, Sep. 1995.
- Lindley, C., "JPEG-Like Image Compression, Part 2", Dr. Dobb's Journal, Aug. 1995, pp. 62-66, 102-105.
- Lindley, C., "JPEG-Like Image Compression, Part 1", Dr. Dobb's Journal, Jul. 1995, pp. 50-58, 101-102.
- Morris, J. et al., "Fault Tolerant Networks of Workstations", Proc. Of the 3rd Int'l Conf. on High Performance Computing, IEEE, pp. 271-276, Dec. 1996.
- Ness, R., "Hardware-software combo could simplify MPEG real-time video compression", Electronic Design, May 3, 1993, p. 36.
- Nowatzky et al., "Are Crossbars Really Dead? The Case for Optical Multiprocessor Interconnect Interconnect Systems", Proceedings of the Annual Symposium on Computer Architecture, ACM, vol. 22, Jun. 1995, pp. 106-115, XP 000687800.
- Ozer, "Digital Video: Shot by Shot", PC Magazine, Apr. 11, 1995, pp. 104-107, 110.
- Ozer, J., "Why MPEG is Hot", PC Magazine; Apr. 11, 1995, pp. 130-131.
- Plotkin, "The Digital Compression Facility—A Solution to Today's Compression Needs", 1994 IEEE; pp. 445-449.
- Qiao et al., "Time-Division Optical Communications in Multiprocessor Arrays", ACM, 1991, pp. 644-653, XP 000337522.
- Rincon et al., "The Changing Landscape of System-on-a-chip Design", MicroNews, Third Quarter 1999, www.chips.ibm.com/micronews/vol5_no3/rincon.html, pp. 1-10, vol. 5, No. 3.
- Sachs, M. et al., "LAN and I/O Convergence: A Survey of the issues", Computer, Dec. 1994, pp. 24-32.
- Sakano, et al., "A Three-Dimensional Mesh Multiprocessor System Using Board-to-Board Free-Space Optical Interconnects: COSINE-III", IEEE, 1993, pp. 278-283, XP 000463415.
- Schroeder, E. "New Offerings Buoy MPEG as Video Standard", Desktop Computing, PC Week, May 8, 1995, pp. 1 and 29.
- Shen et al., "A Parallel Implementation of an MPEG1 Encoder: Faster than Real-Time!", Proc. Of SPIE Conf. on Digital Video Compression, San Jose, CA, Feb. 1995.
- McHenry et al., "An FPGA-Based Coprocessor for ATM Firewalls", Field-Programmable Custom Computing Machines 1997, Apr. 16-18, 1997, pp. 30-39, XP-002157218.
- Shiuan, J. et al., "Client-Server Based Ray-Tracer Using ASTRA: An Asynchronous RPC Mechanism", Computer Communications, vol. 19, No. 5, pp. 445-455, May 1996.
- Szabo, B. et al., "Design Considerations for JPEG Video and Synchronized Audio in a Unix Workstation Environment", USENIX—Summer '91, pp. 353-368.
- Vetter, R., "ATM Concepts, Architectures, and Protocols", Communications of the ACM, Feb. 1995; vol. 38, No. 2, pp. 30-38, 109.
- Vetter, R. et al., "Issues and Challenges in ATM Networks", Communications of the ACM, Feb. 1995; vol. 38, No. 2, pp. 28-29.
- Waldspurger et al., "Spawn: A Distributed Computational Economy", IEEE Transactions on Software Engineering, vol. 18, No. 2, Feb. 1992, pp. 103-117 XP002124500.
- Yoshida, J., "MPEG-2 Encoders Make Show of Force at NAB", Electronic Engineering Times, Apr. 10, 1995.
- Yu, Y. et al., "Software Implementation of MPEG-II Video Encoding Using Socket Programming in LAN", SPIE vol. 2187, pp. 229-240, 1994.
- Waltz et al., "Make 'em pay: Billing Net Usage", MacWeek, vol. 6 (No. 27), p. 24 (2) (Dialog full text), (Jul. 27, 1992).
- "The Economics of Network Billing: Network Billing and Monitoring Systems can Improve Efficiency and Cut Costs", IBM System User, vol. 14 (No. 11), p. 53 (1) (Dialog Fulltext), (Nov. 1993).
- "Let Your Computer Make Money While You Sleep", Newsbytes, p. 1 (Dialog Fulltext), (Aug. 16, 1996).
- Regenold et al., "A Single-Chip Multiprocessor DSP Solution for Communication Applications", ASIC Conference and Exhibit 1994, pp. 437-440.
- Geppert, L. Solid State [Trend/Development], IEEE Spectrum, v. 33, iss. 1, 1996, pp. 51-55.
- Li, Yao, "Free-space Optical Bus-based WDMA Interconnects for Parallel Computation", LEOS '92 Conference Proceedings, Lasers and Electron-Optics Society Annual Meeting, p. 588-589, Nov. 16-19, 1992.
- Dickinson et al., "An Integrated Free Space Optical Bus", 1989 IEEE International Conference on Computer Design, VLSI in Computers and Processors, p. 62-65, Oct. 2-4, 1989.
- Natarajan et al., "Bi-Directional Optical Backplane Bus for General Purpose Multi-Processor", Journal of Lightwave Technology, vol. 13, No. 6, p. 1031-1040, Jun. 6, 1995.
- Zhao et al., "General Purpose Bidirectional Optical Backplane: High Performance Bus for Multiprocessor Systems", Massively Parallel Processing Using Optical Interconnections, 2nd International Conference, p. 188-195, Oct. 23-24, 1995.
- Wu et al., "Microprocessor Control Signal Transmission Through Optical Fiber", Conference Record of 1992, IEEE Industry Applications Society Annual Meeting, p. 1747-1750, Oct. 4-9, 1992.
- Fox et al., "Towards Web/Java based High Performance Distributed Computing—an Evolving Virtual Machine", www.npac.syr.edu/projects/webpace/doc/hpdc5/paper, Jun. 10, 1996, 11 pages.
- None, "PC Vision: Intel unveils plans to bring PCs to Vehicles"; EDGE: Work-Group Computing Report, EDGE Publishing, p. 1-2 (Oct. 28, 1996).
- The American Heritage College Dictionary 4th Ed.—definition of "firewall" (2007).
- White, "Covert Distributed Processing with Computer Viruses", Advances in Cryptology, Crypto 89, Springer LNCS, v. 435, pp. 616-619, 1989.
- Foster et al., "The Grid: Blueprint for a New Computing Infrastructure", Morgan Kaufman Publishers, Inc., 1998.
- Hwang et al., "Scalable Parallel Computing", WCB McGraw-Hill, 1998.
- Wilkinson, et al., "Parallel Programming" Prentice Hall, 1998.
- Patterson et al., "Computer Architecture: A Quantitative Approach" (2nd Edition), Morgan Kaufmann Publishers, Inc., 1996.
- Culler et al., "Parallel Computer Architecture", Morgan Kaufmann Publishers, Inc., 1998.
- Hennessy et al., "Computer Organization and Design", Morgan Kaufmann Publishers, Inc., 1998.
- Slater, "The Microprocessor Today", IEEE Micro 1996, pp. 32-44.
- Steinert-Threlkeld; "New Breed of Chip TI develops a super circuit"; The Sun Baltimore; May 4, 1992.
- Dallas Morning News; "LSI holds big plans for tiny chips Versatility of 'system on a chip' creates niche in microelectronics;" Mar. 4, 1996.
- Mokhoff; "System-on-a-chip comes to wireless arena;" Electronic Engineering Times; Feb. 12, 1996.

(56)

References Cited

OTHER PUBLICATIONS

Cindi; "System on a Chip" stars at ISSCC;" Electronic News; Feb. 19, 1996.

Ang; "System-on-a-chip to define next-generation set-top box"; Electronic Engineering Times; Dec. 15, 1995.

Marc; "New family of microprocessor cores from LSI Logic extends customers' system-on-a-chip design capability" Nov. 7, 1994.

Wall Street Journal; "Technology Brief—Advance Micro Devices Inc.: Company unveils Microchip for Hand-Held Computers"; Oct. 18, 1993.

Gelsinger, Patrick et al. "Microprocessors circa 2000," IEEE Spectrum, Oct. 1989 pp. 43-47.

Yu, Albert. "The Future of Microprocessors," IEEE Micro, Dec. 1996, pp. 46-53.

McWilliams. "Dell to Phase Out Computers Using Intel's Itanium," The Wall Street Journal, Online, Sep. 15, 2005.

David Pescovitz, "Power of the PC", Scientific American, pp. 27-28 (Apr. 2000).

Stephen H. Wildstrom, "The Problem with Firewalls", Business Week, pp. 25 (Mar. 20, 2000).

J. McH., "Build Your Own Supercomputer", Forbes, pp. 228 (Nov. 15, 1999).

Wilkinson, Barry et al., "Parallel Programming: Techniques and Applications Using Networked Workstations and Parallel Computers", Chapter 4, Prentice-Hall, Inc., 1999.

Baker, Lou at al., "Parallel Programming", Chapter 4, McGraw Hill Companies, Inc., 1996.

Kayssi, A.; Harik, L.; Ferzli, R.; Fawaz, M: "FPGA-based Internet Protocol Firewall Chip"; Electronics, Circuits and Systems, 2000. ICECS 2000. The 7th IEEE International Conference on vol. 1, Dec. 17-20, 2000 pp. 316-319 vol. 1.[retrieved from IEEE database 6.9.08].

English language abstract of EP 0 647 052, published Apr. 5, 1995. Newton's Telecom Dictionary, "Mobile IP"; p. 459; Mar. 1998.

Holographic Quantum Computer, <http://www.unitelnw.com/holo1/index> (May 1999).

Jonathan Fahey, "Screen Grab"; Forbes, pp. 52-53, Mar. 5, 2001.

Ronald Grover et al., "TV Guy", Business Week, pp. 66-76, Mar. 12, 2001.

"Distributed Computing", Red Herring, No. 87, pp. 166-202, Dec. 18, 2000.

Om Malik, "Distributed Computing Redefines Computer Networks, Underpinning Innovation, Company Formation, and Investments", Red Herring No. 86, pp. 95-96 and 105, Dec. 4, 2000.

Alan Zeichick, "P2P Network Explained", Red Herring; No. 86, pp. 204 and 206, Dec. 4, 2000.

"Napster is Clouding Grove's Crystal Ball"; Fortune, pp. 271-272, May 29, 2000.

Gordon Force, Sr., "Portable Data Encryption Approaches", WESTCON/95, Conference Record: Microelectronics Communications Technology Producing Quality Production Mobile and Portable Power emerging Technologies, Nov. 7-9, 1995, pp. 413-419.

A.D. Romig, Jr., "High Performance Microsystem Packaging: A Perspective", Microelectron Reliab., vol. 37, No. 10/11, pp. 1771-1781 (1997).

File History for U.S. Appl. No. 14/092,707 from Nov. 24, 2014 to present.

File History for U.S. Appl. No. 14/333,759 from Dec. 16, 2014 to present.

File History for U.S. Appl. No. 14/328,587 from Jan. 5, 2015 to present.

File History for U.S. Appl. No. 14/230,713 from Dec. 22, 2014 to present.

* cited by examiner

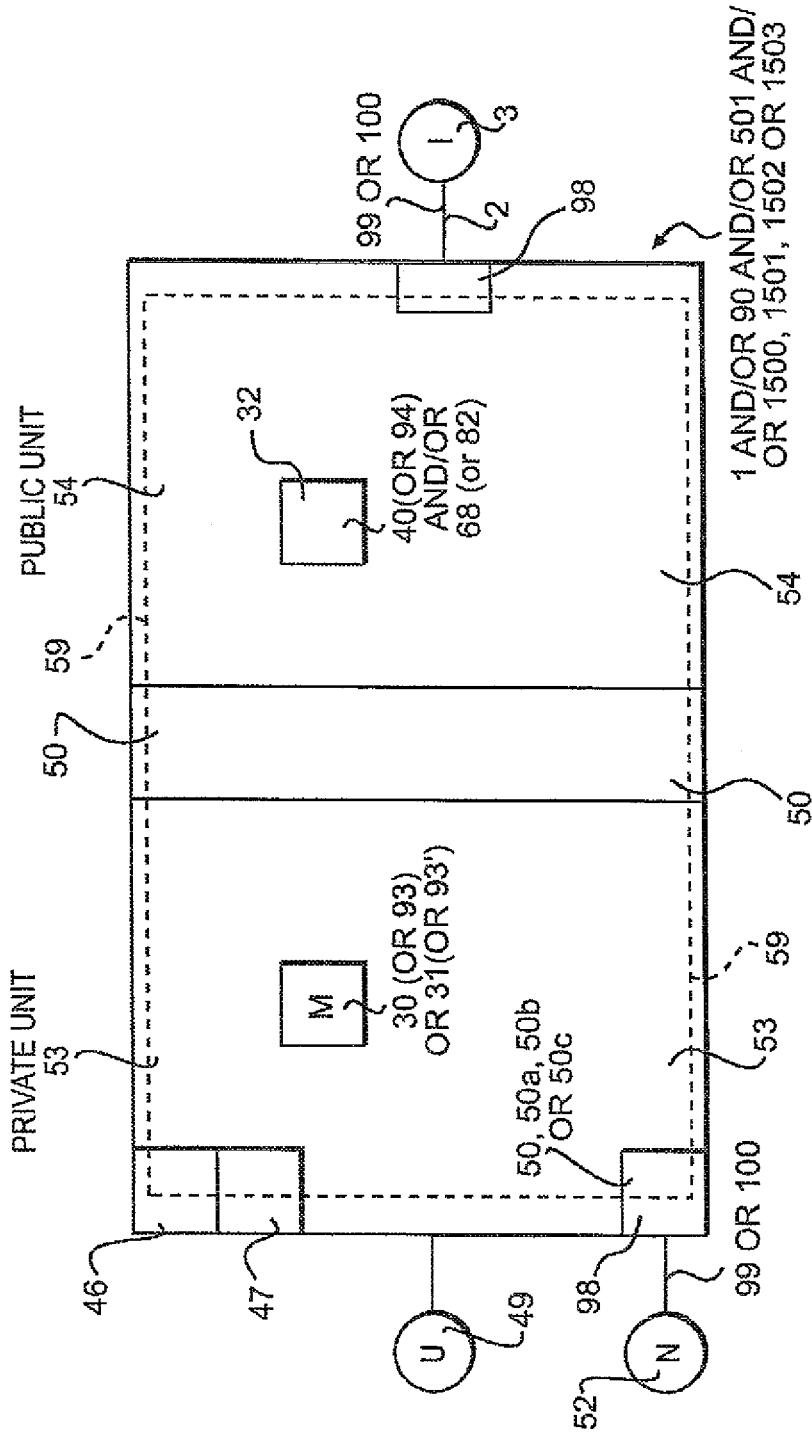

FIG. 1

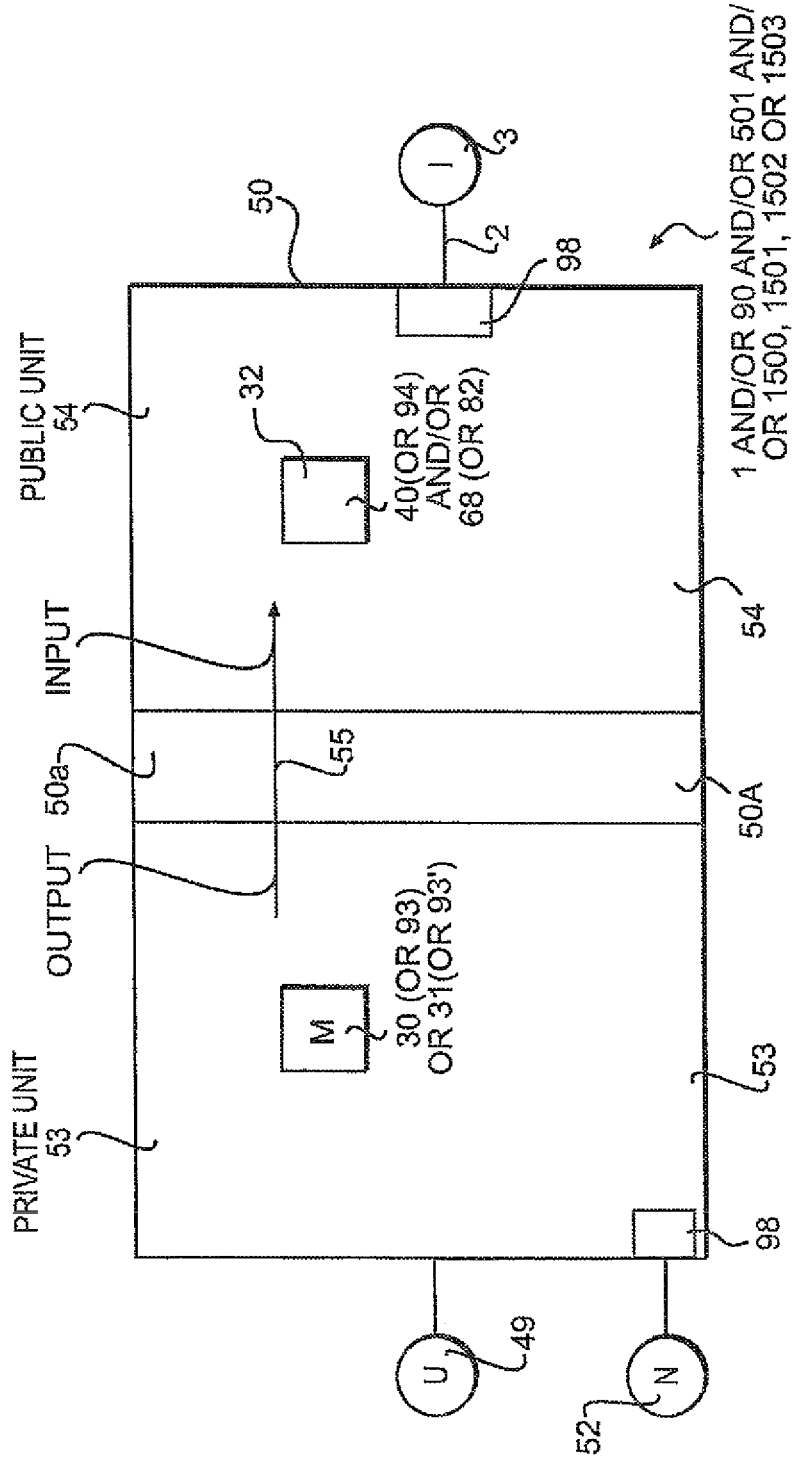

FIG. 2

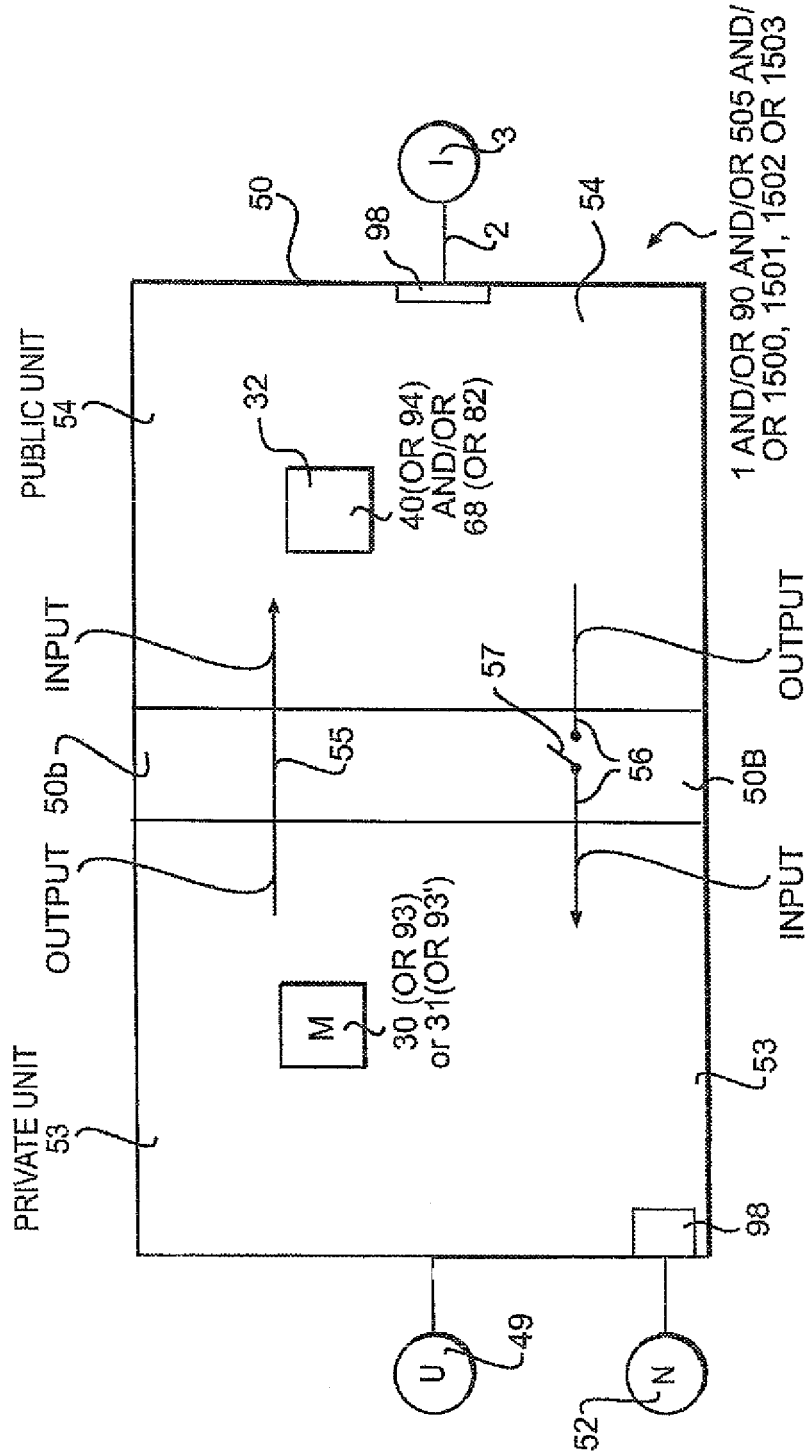

FIG. 3

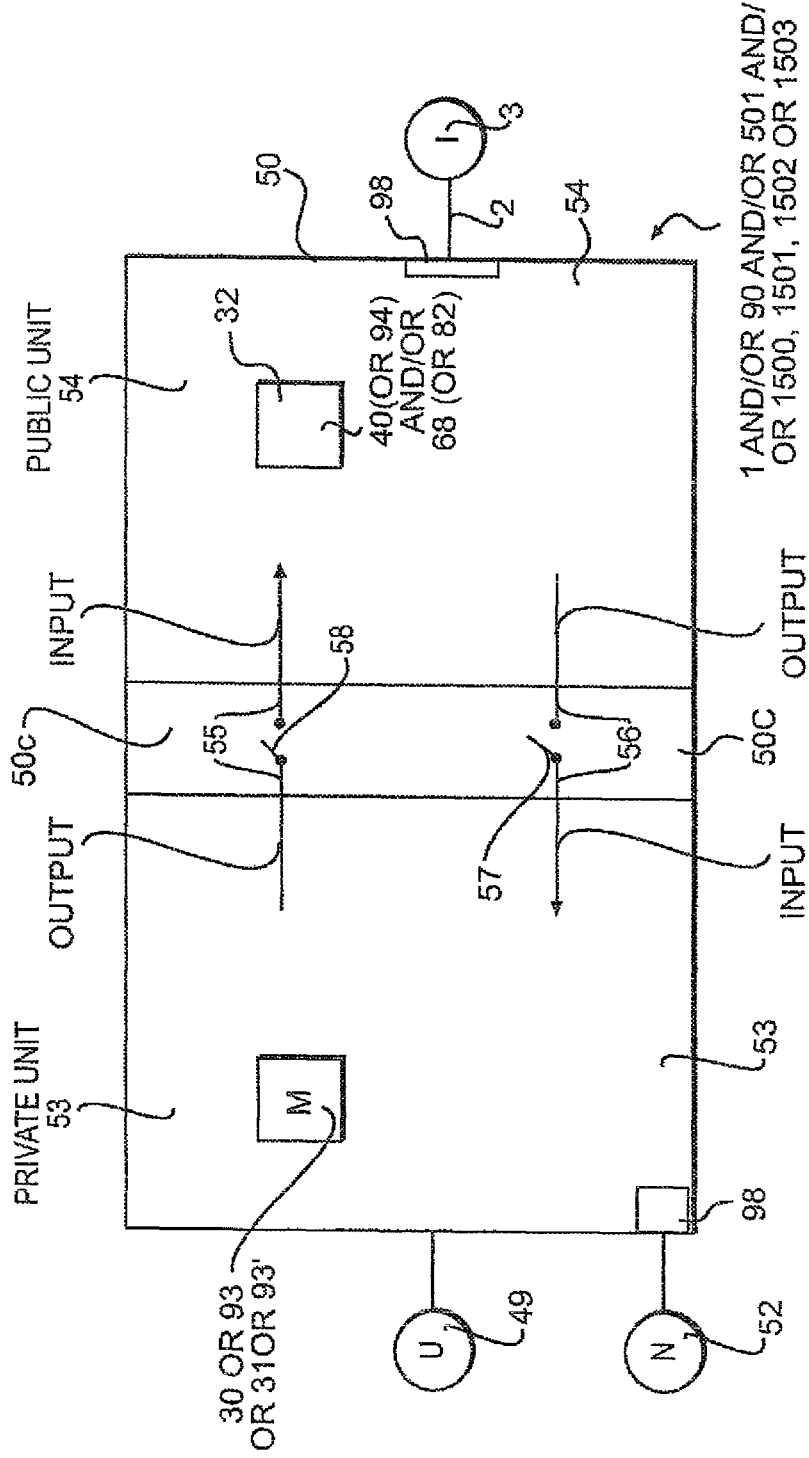

FIG. 4

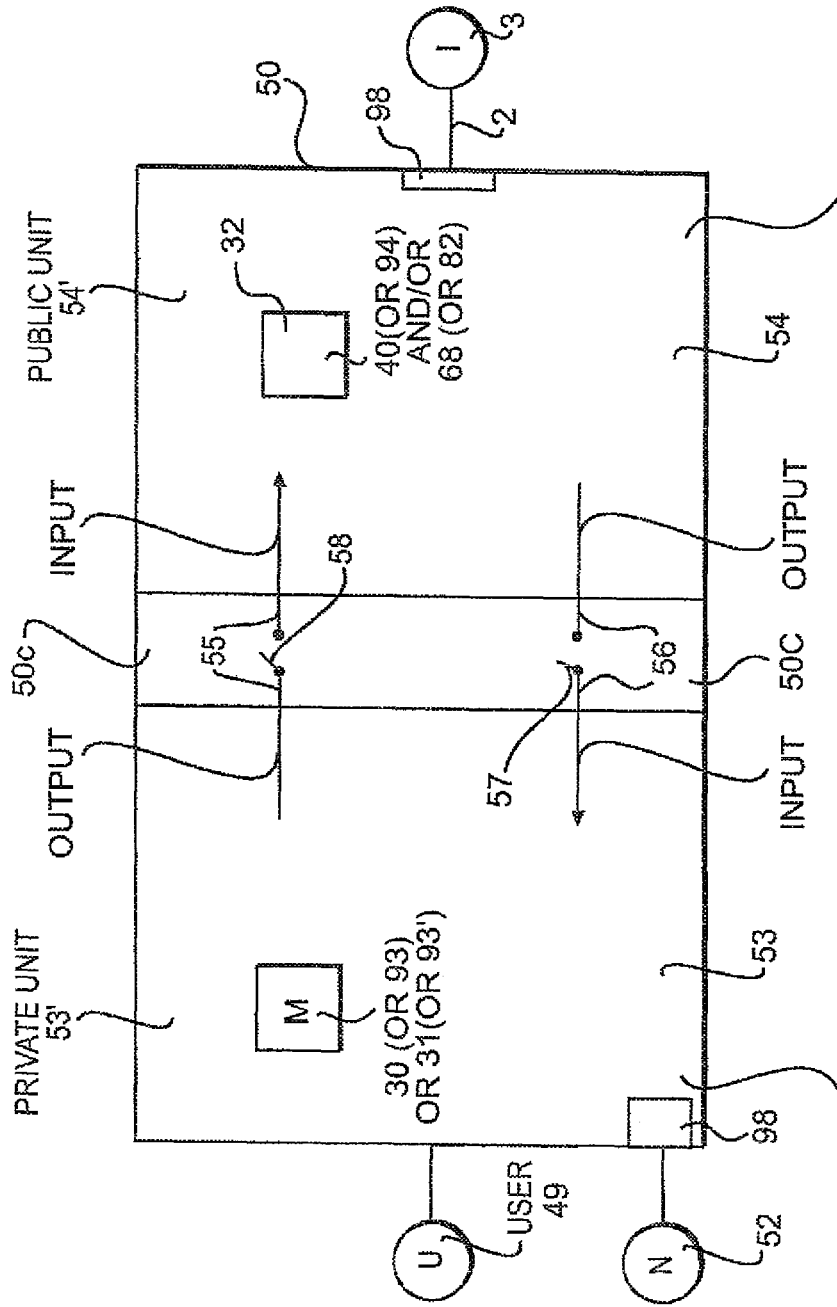

FIG. 5
FIRST 1 AND/OR 90 AND/OR 501 AND /OR 1500, 1501, 1502 OR 1503
SECOND 1 AND/OR 90 AND/OR 501 AND /OR 1500, 1501, 1502 OR 1503

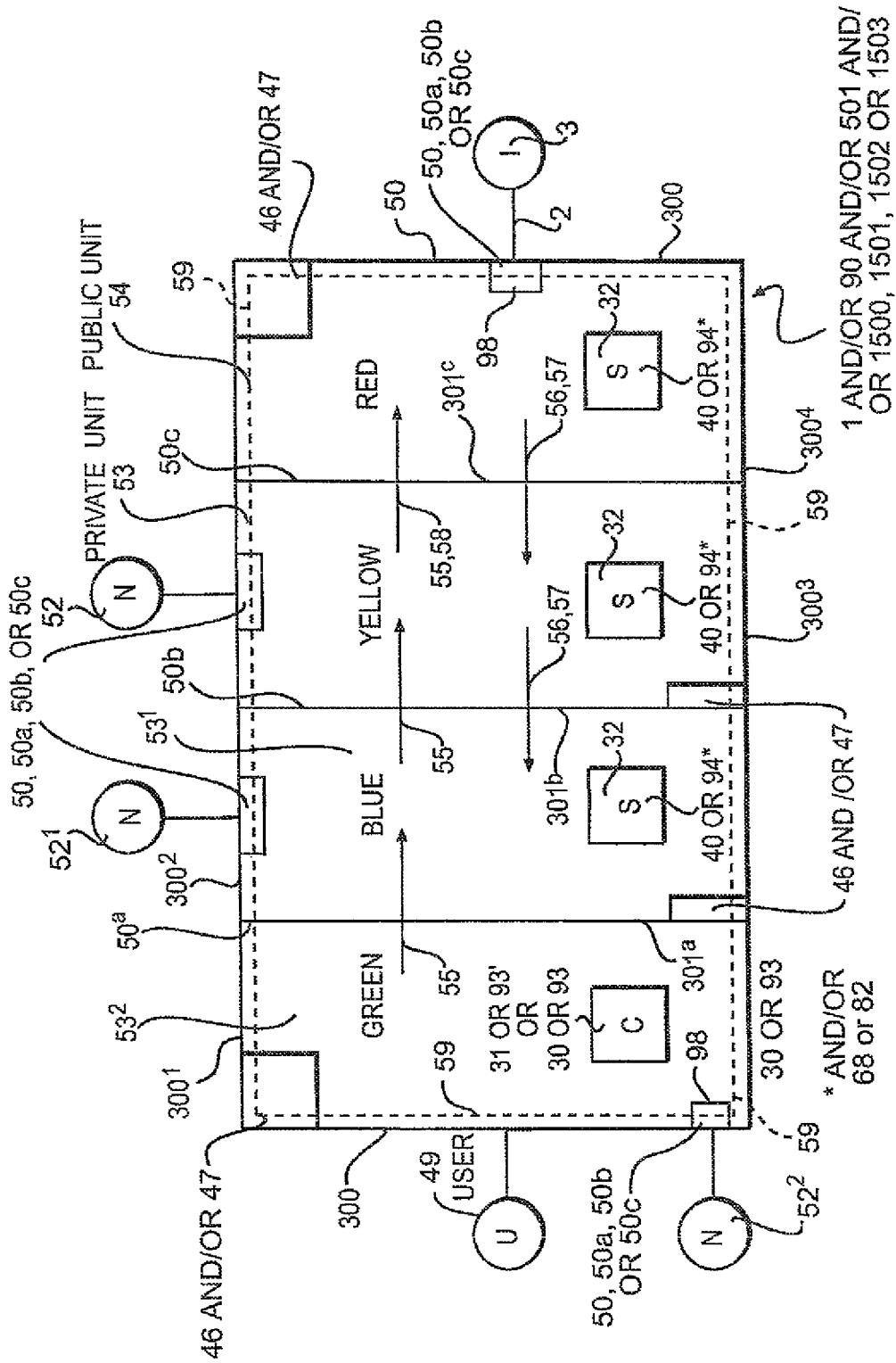
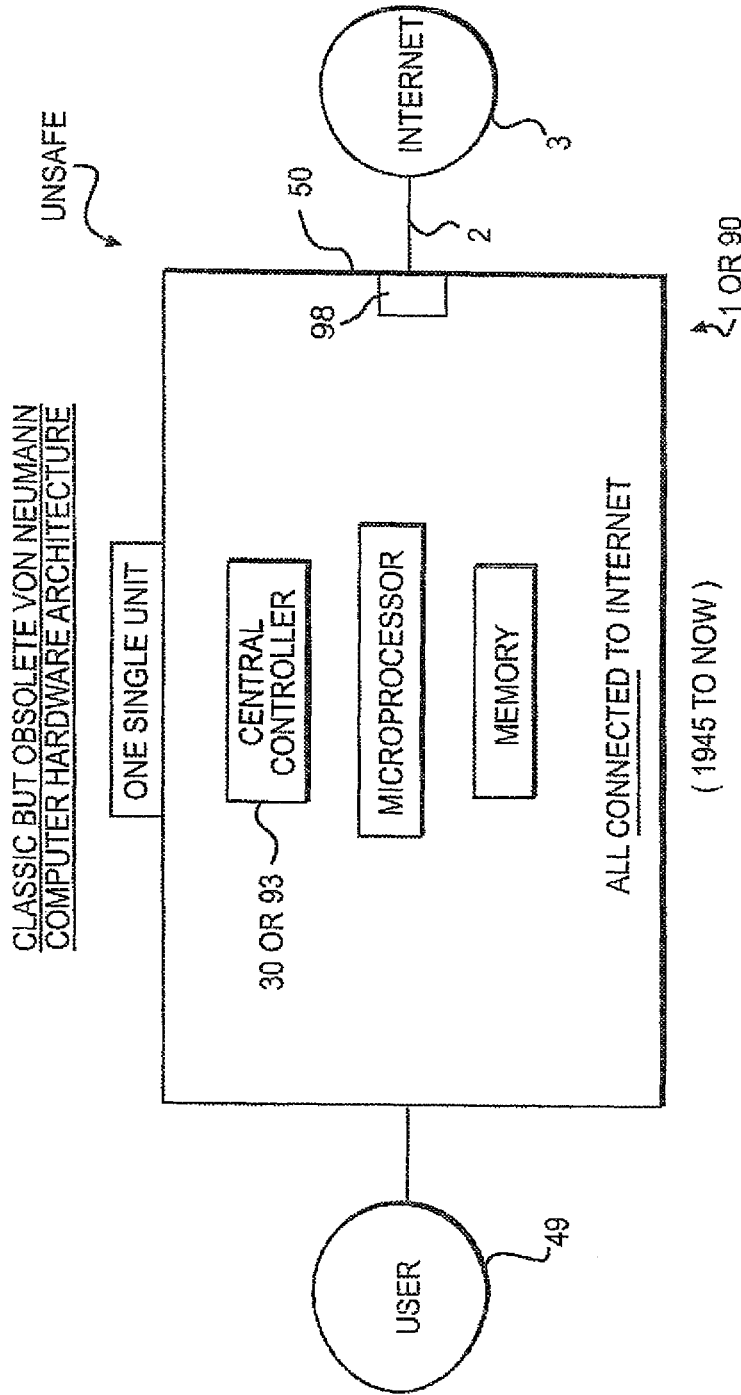
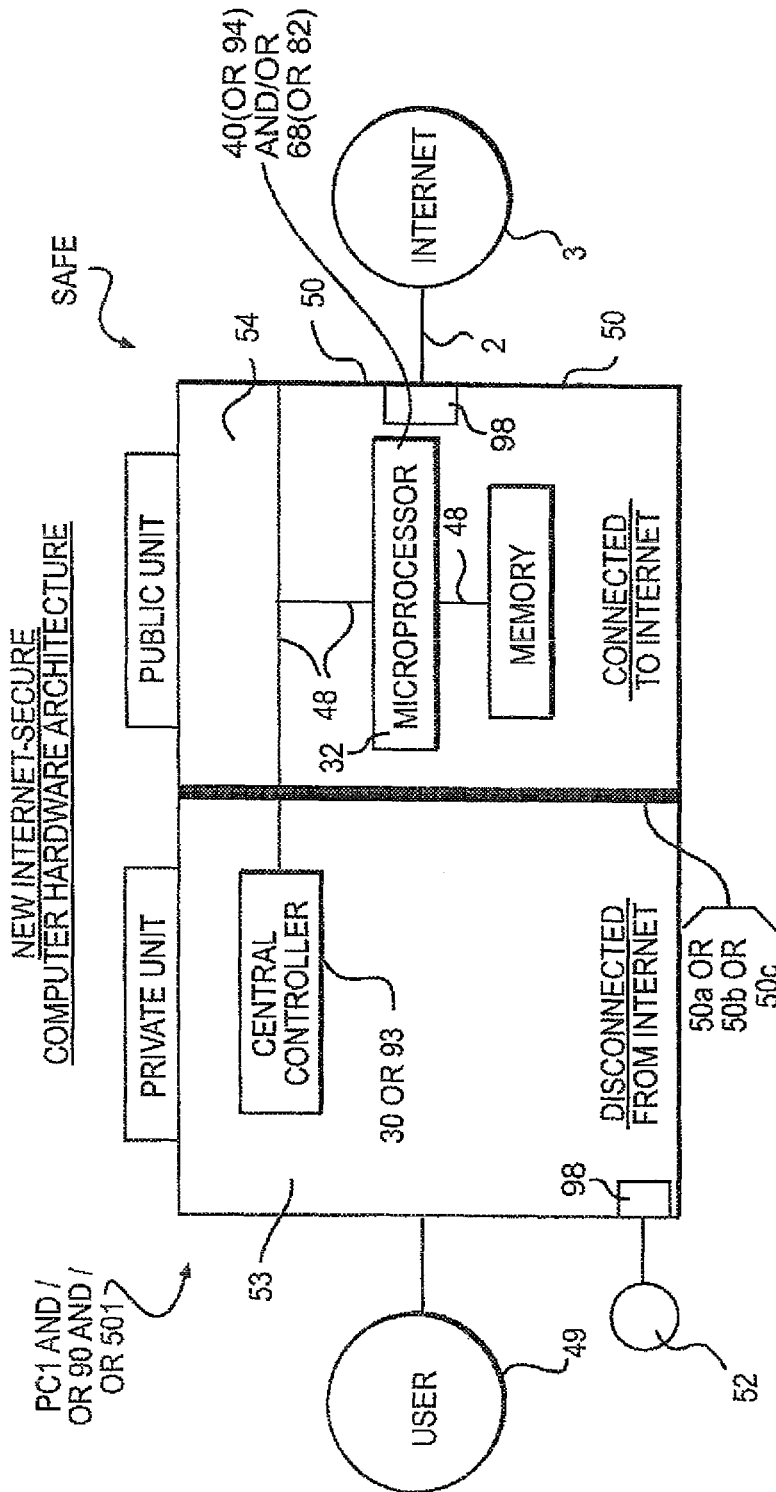

FIG. 6



THE PROBLEM: INTERNET MALWARE HAS POTENTIAL ACCESS TO ENTIRE COMPUTER TO CONTROL ANY PART OR ALL OF IT

FIG. 7



THE MOST BASIC SOLUTION: CENTRAL CONTROLLER IS HARDWARE PROTECTED TO BE INACCESSIBLE FROM INTERNET & CONTROLS ENTIRE COMPUTER

FIG. 8

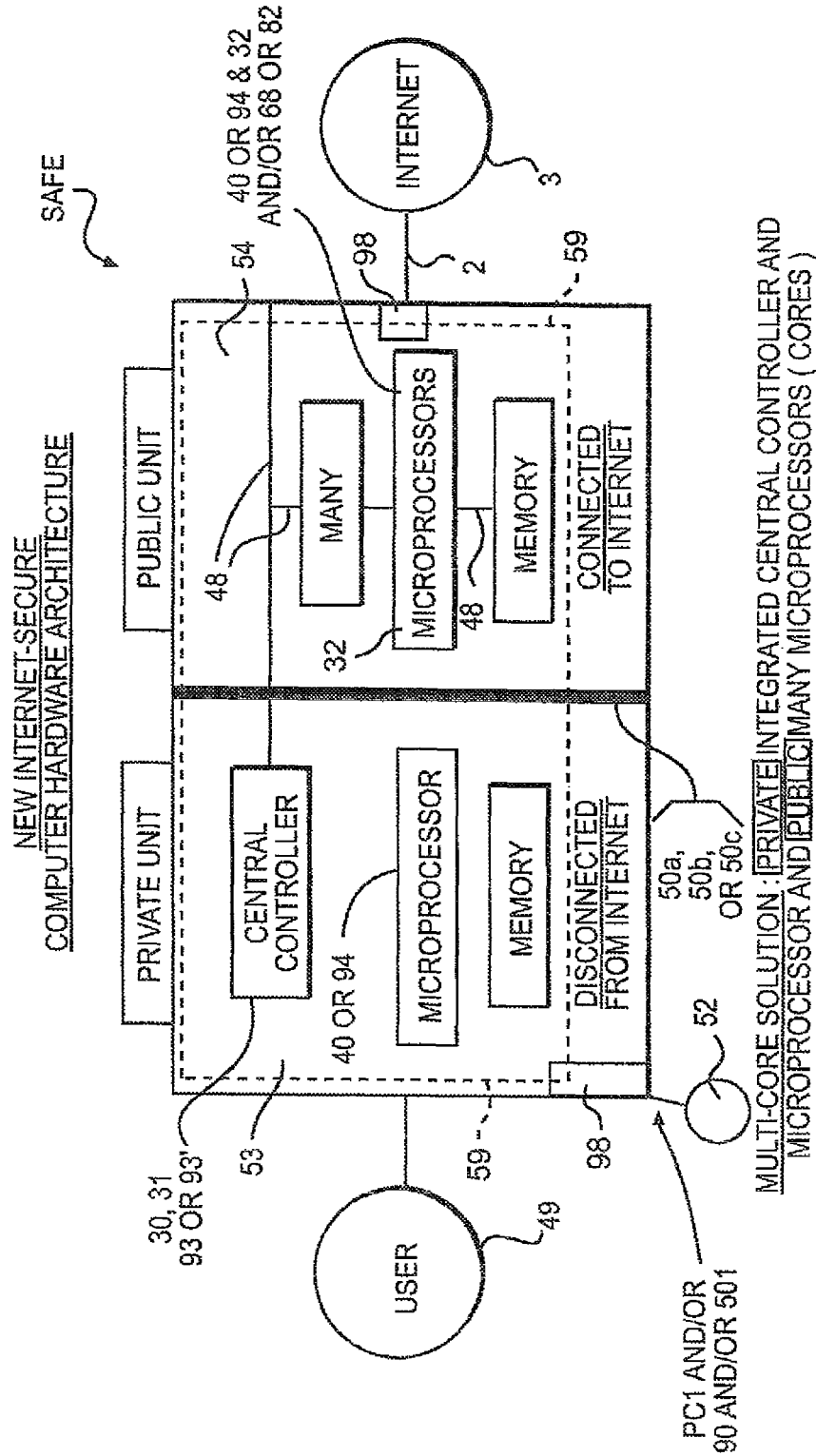

FIG. 9

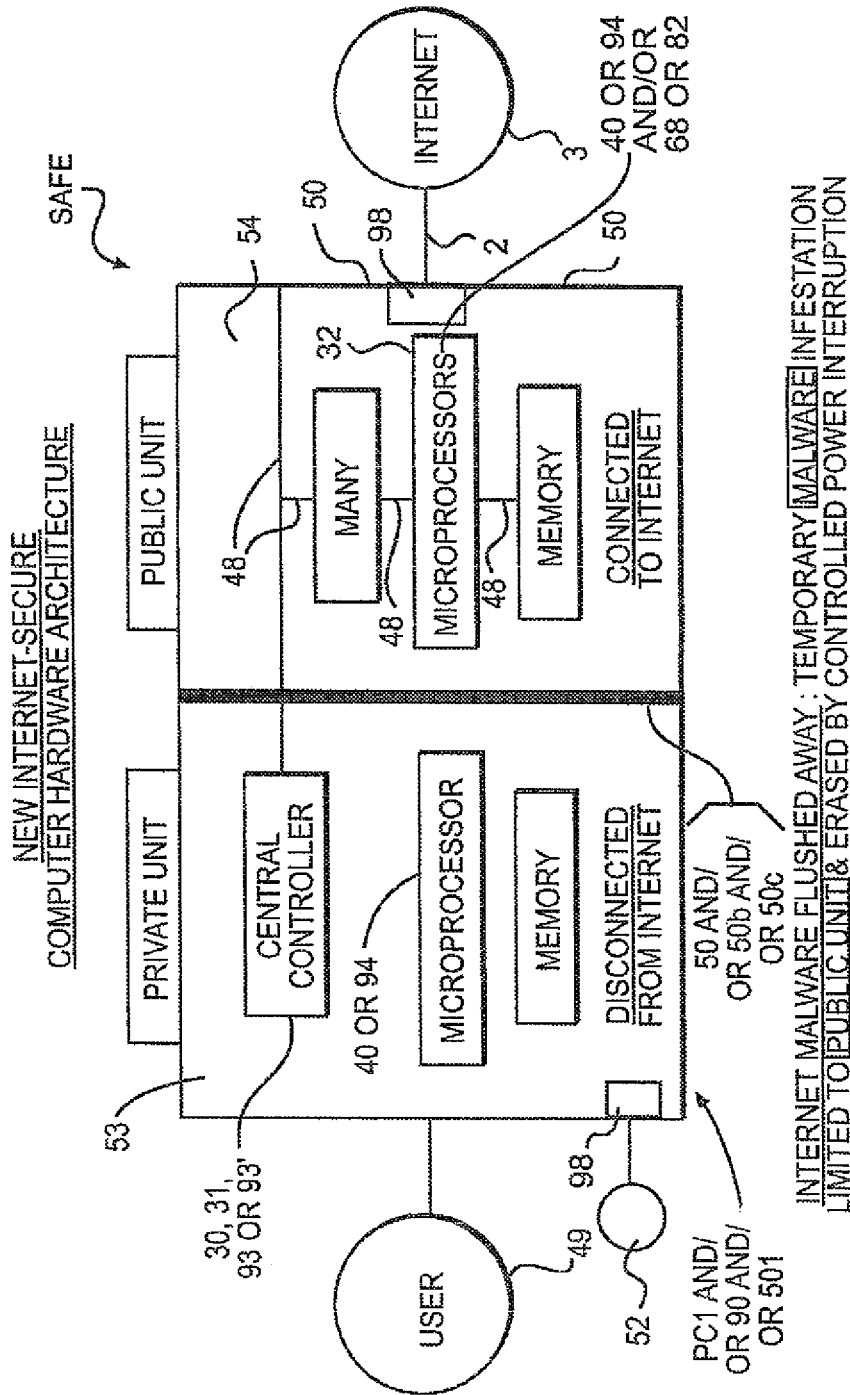

FIG. 10

MATRIX OF MULTIPLE INNER FIREWALLS CAN CREATE MANY SEPARATE COMPARTMENTS

NEW INTERNET-SECURE
COMPUTER HARDWARE ARCHITECTURE

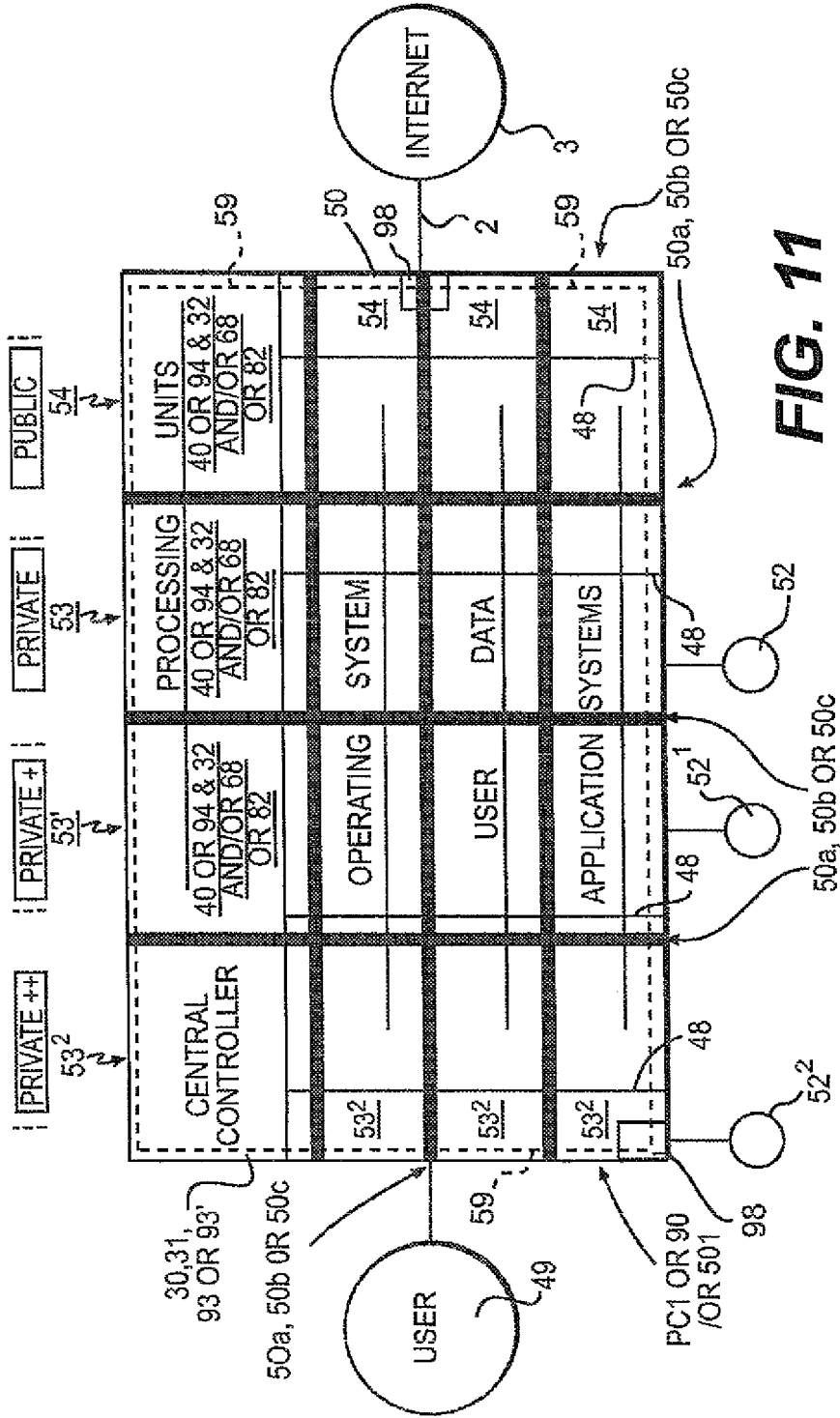

FIG. 11

NEW INTERNET-SECURE
COMPUTER HARDWARE ARCHITECTURE
ANY COMPUTER COMPONENT CAN BE SUBDIVIDED INTO KERNEL AND OTHER
SUBCOMPONENTS PROTECTED BY SUCCESSIVE FIREWALL LAYERS

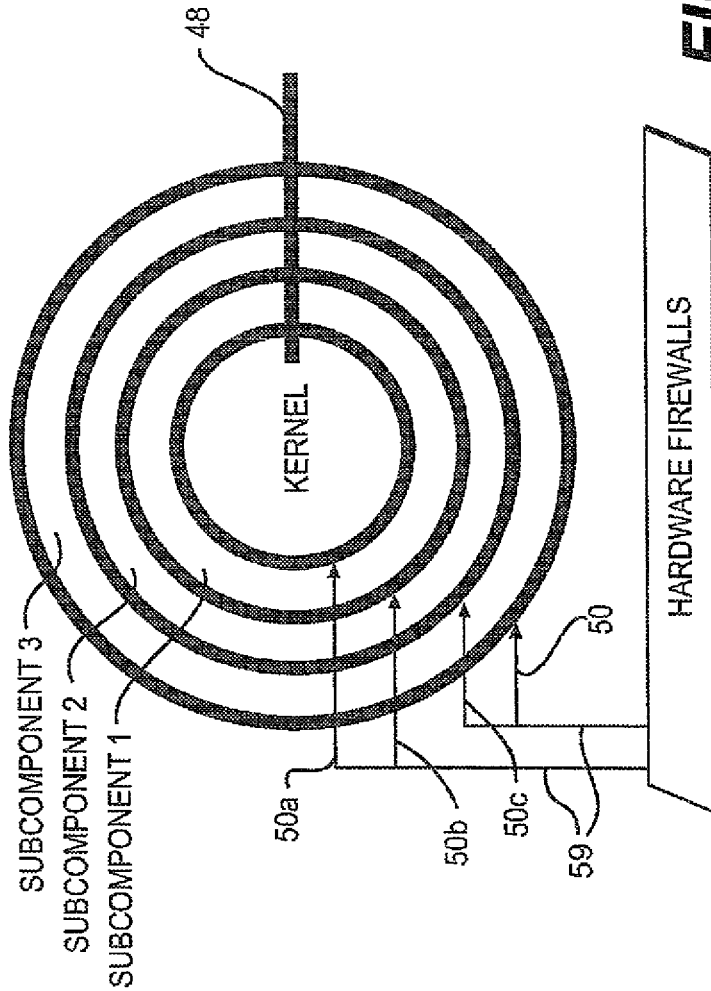

FIG. 12

NEW INTERNET-SECURE
COMPUTER HARDWARE ARCHITECTURE

ANY COMPUTER COMPONENT CAN BE
PROTECTED BY ITS OWN INNER FIREWALL (OR FIREWALLS)

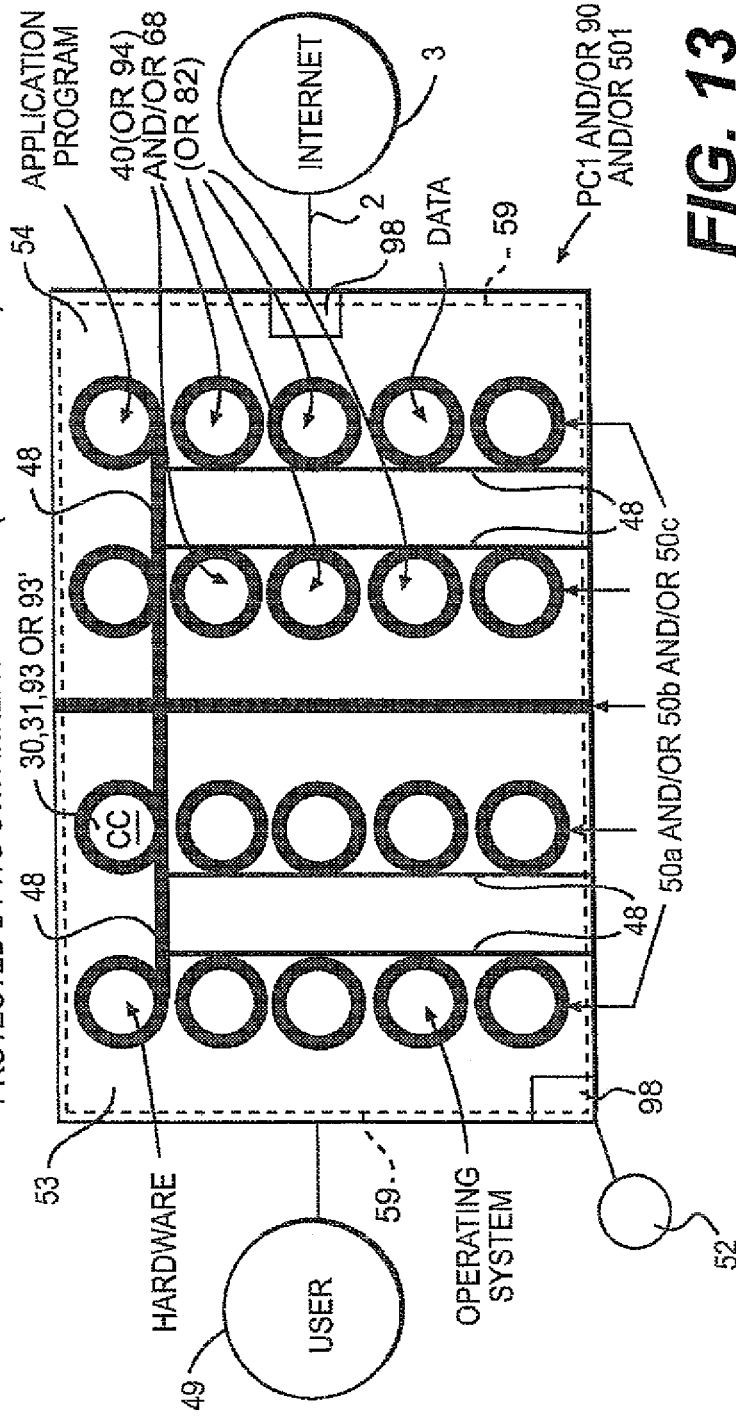
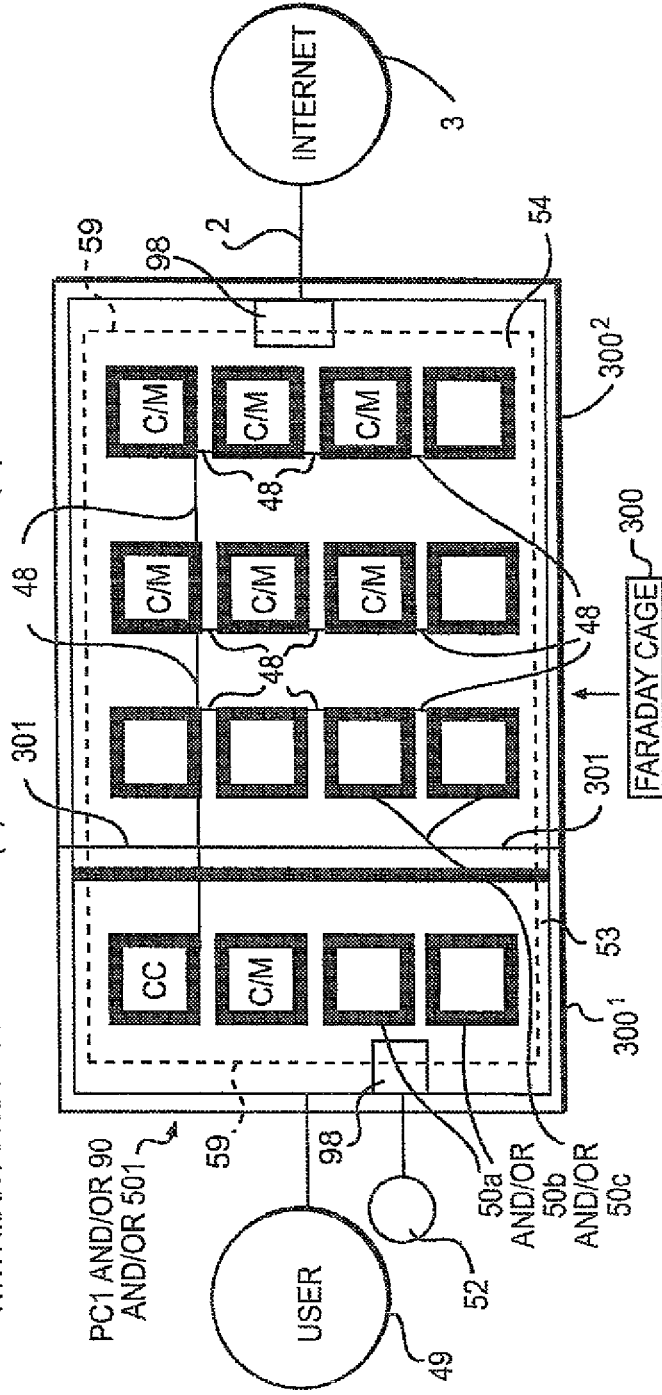

FIG. 13

NEW INTERNET-SECURE
COMPUTER HARDWARE ARCHITECTURE

COMPUTER CAN BE PERSONAL COMPUTER SYSTEM ON A CHIP (SOC) MICROCHIP
WITH MANY PROCESSING CORES (C) AND ASSOCIATED RAM (M), EACH WITH INNER FIREWALL(S)



SURROUNDS COMPUTER TO PROTECT AGAINST ELECTROMAGNETIC PULSE (EMP),
INTERFERENCE FROM OTHER COMPONENTS & SURVEILLANCE

FIG. 14

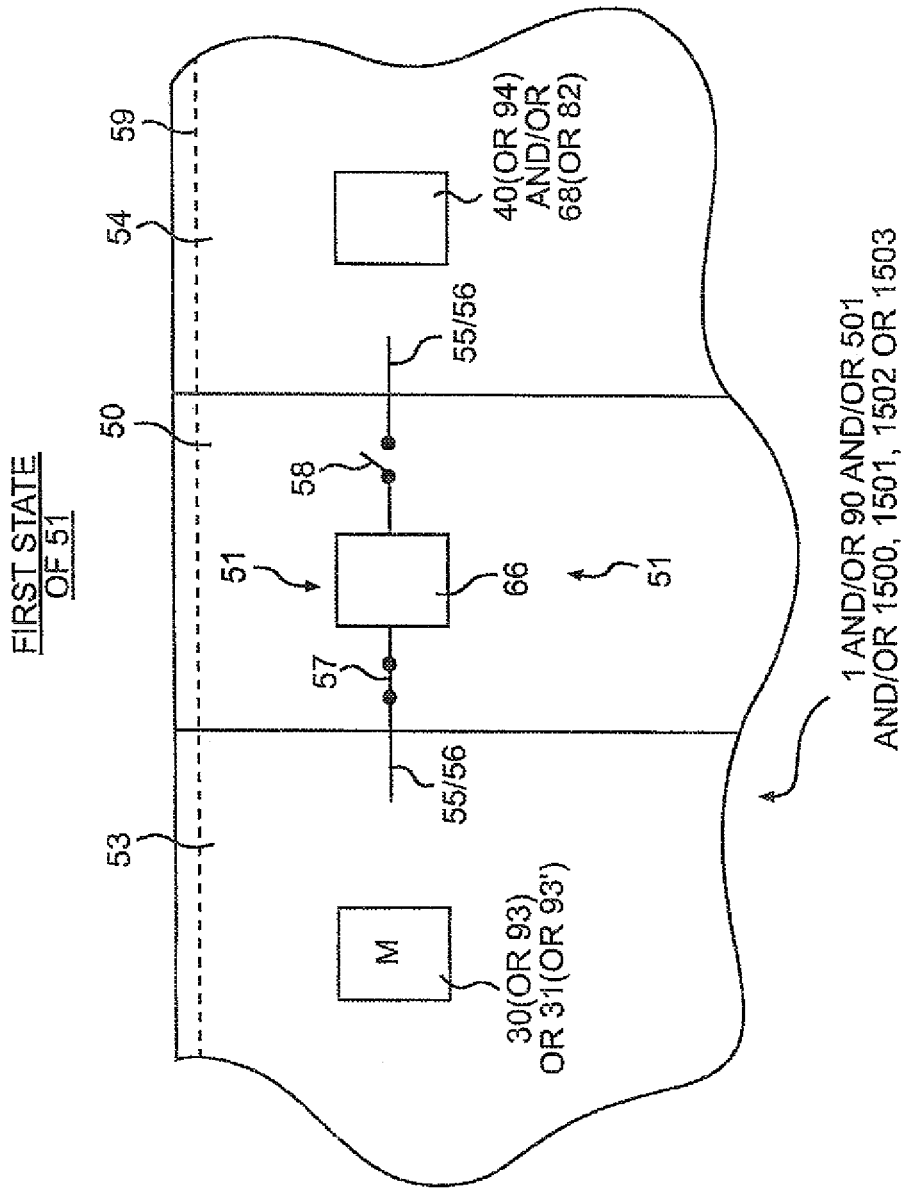

FIG. 15

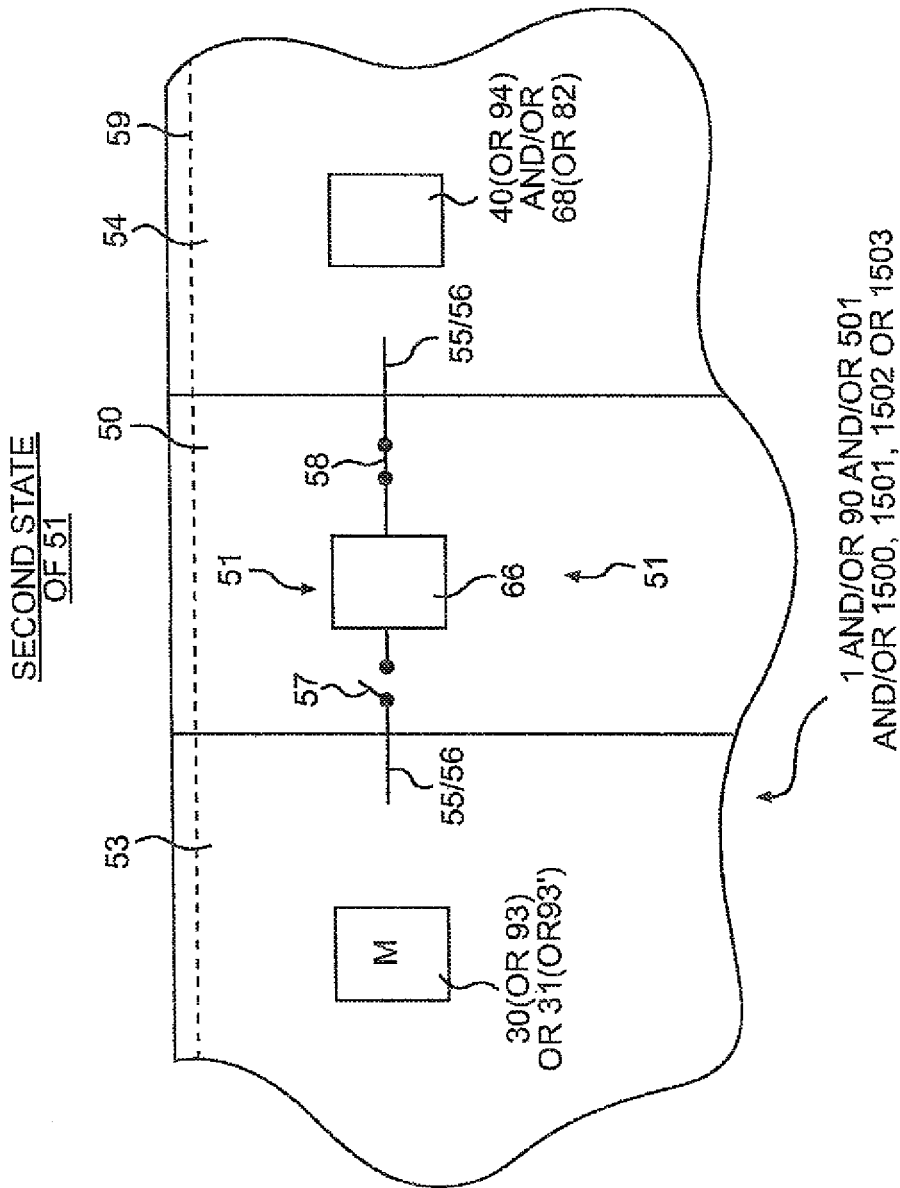
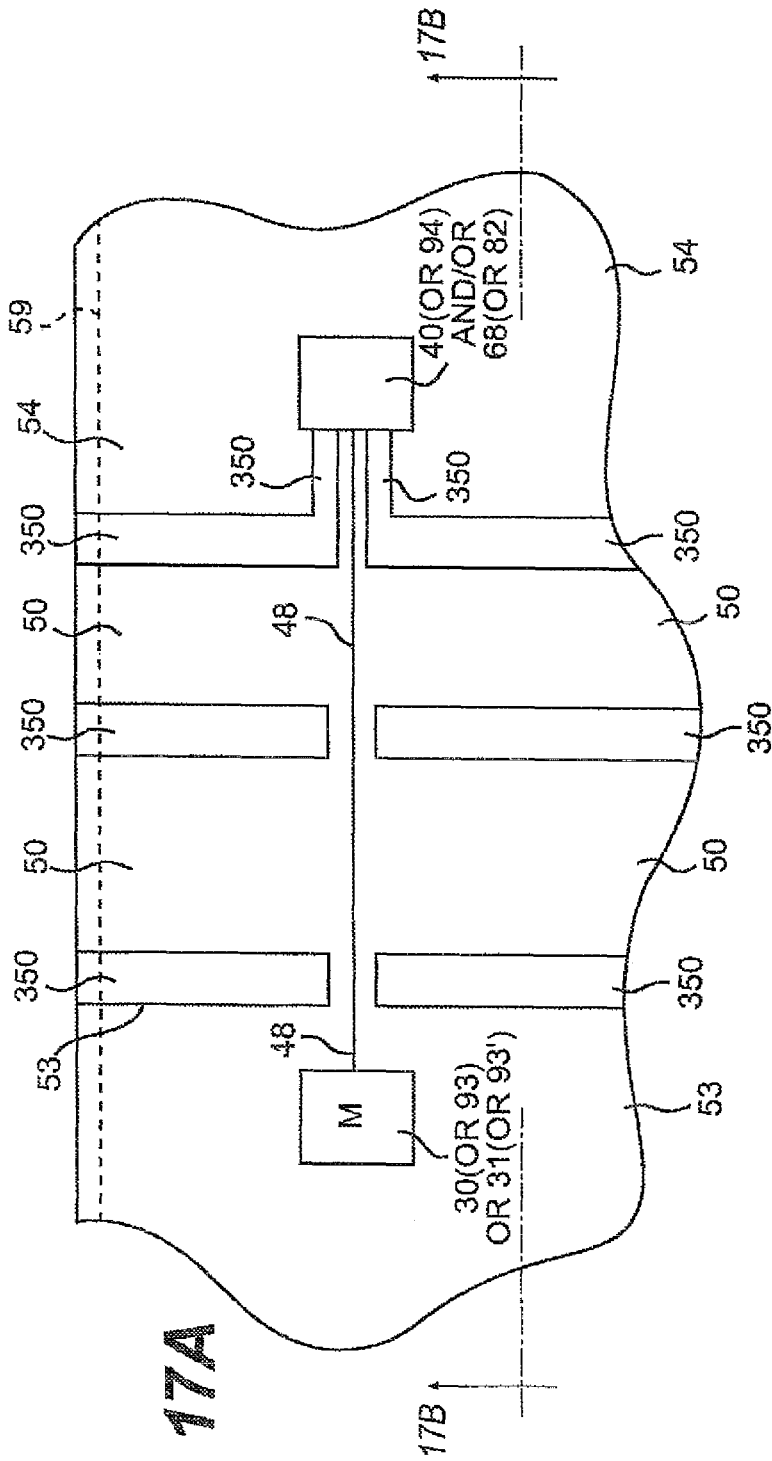
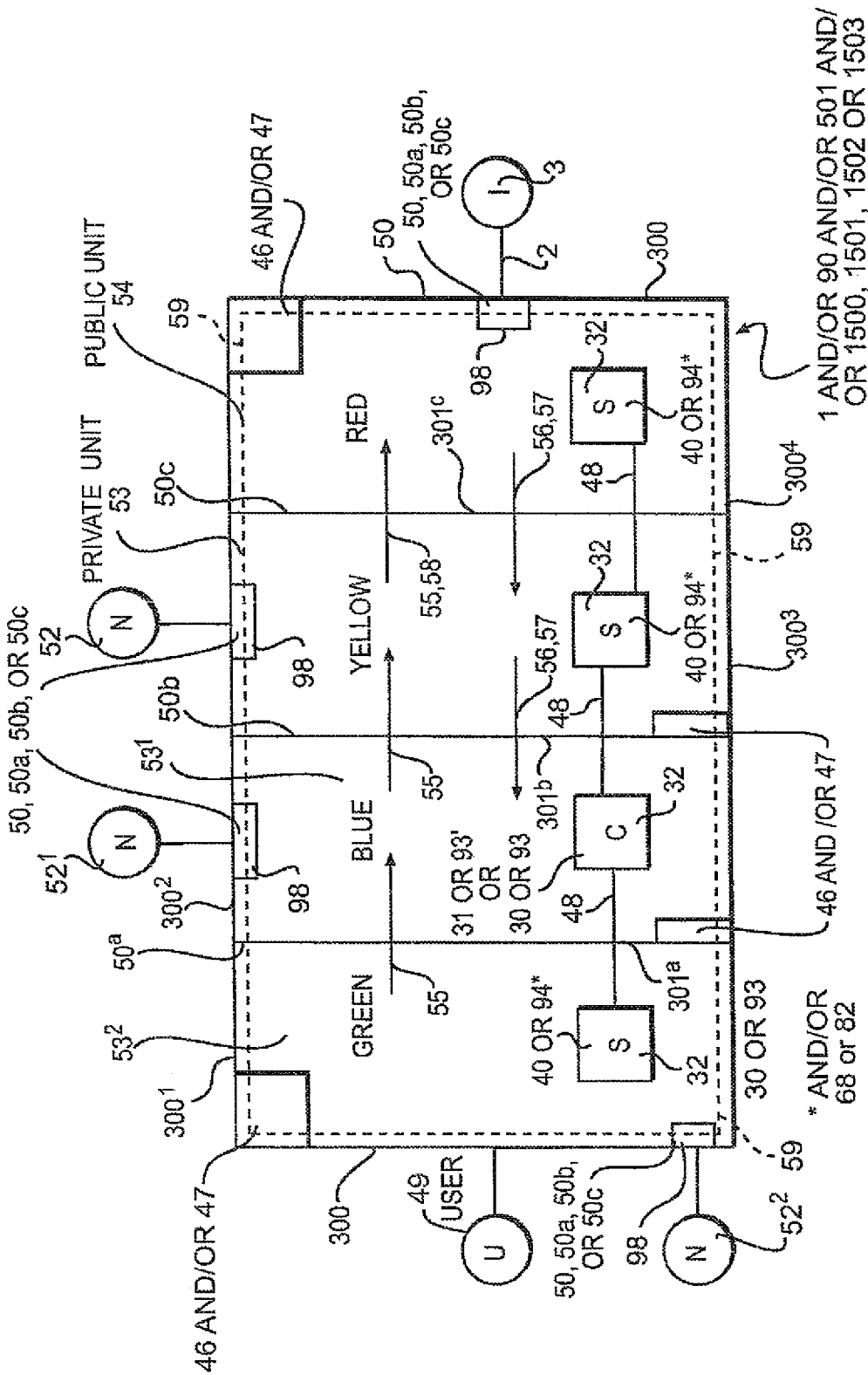

FIG. 16





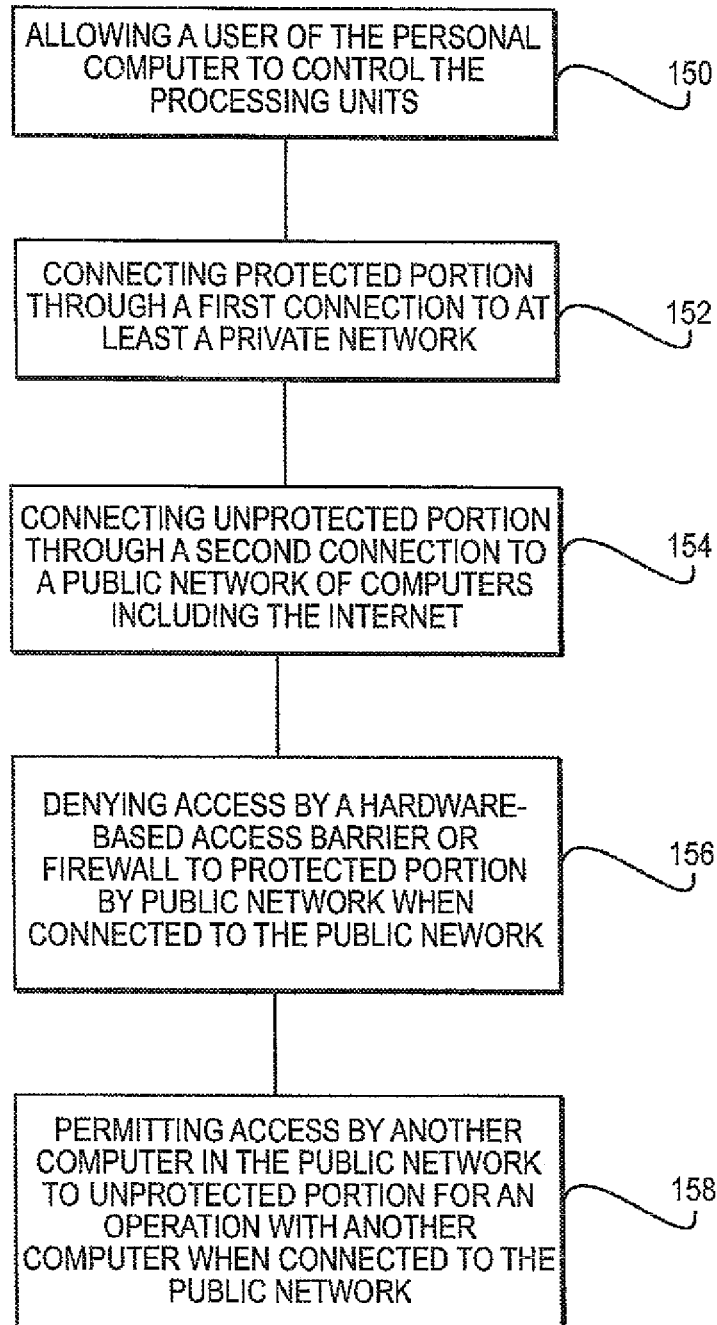

FIG. 19

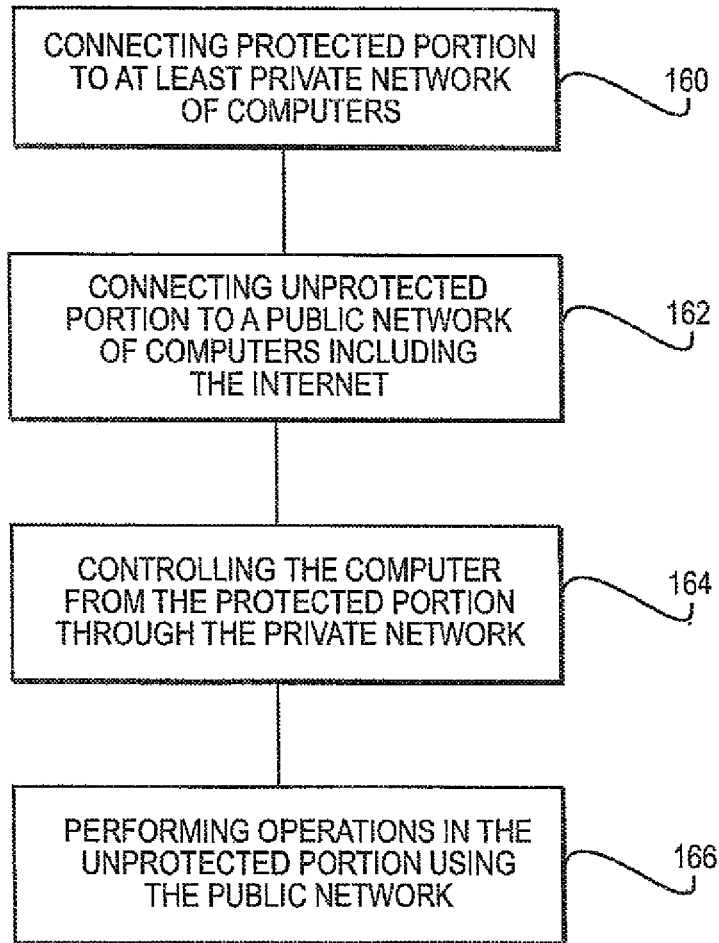

FIG. 20

FIG. 21A

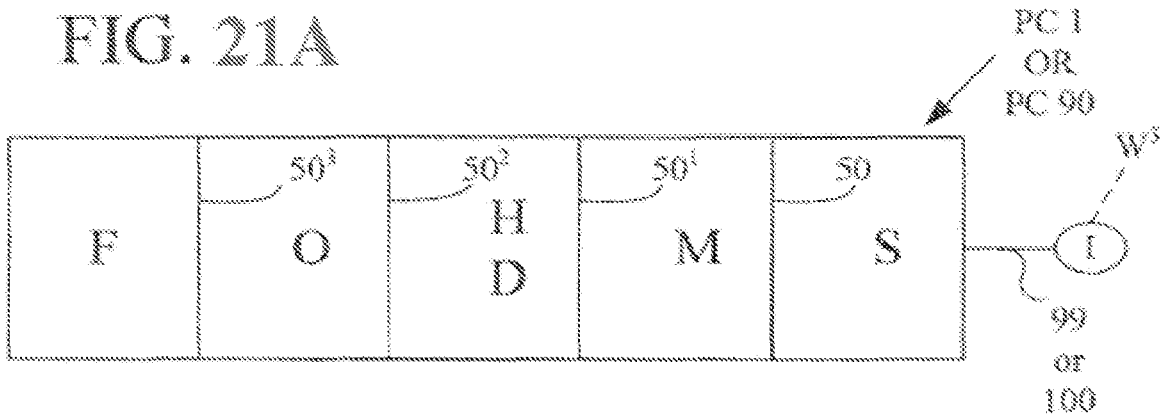

FIG. 21B

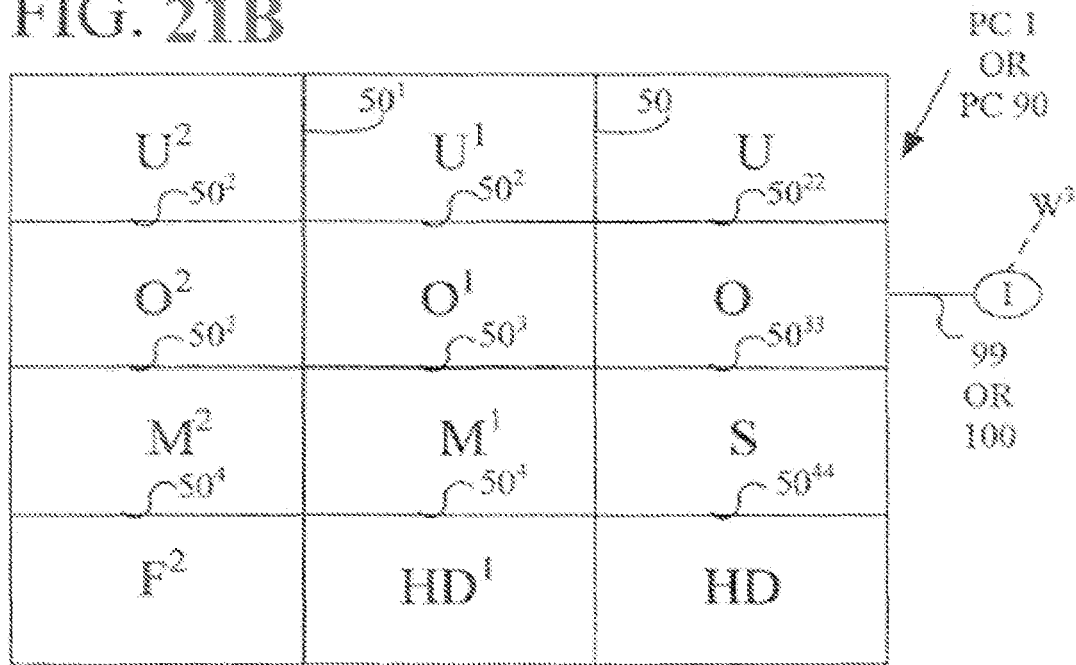

FIG. 21C

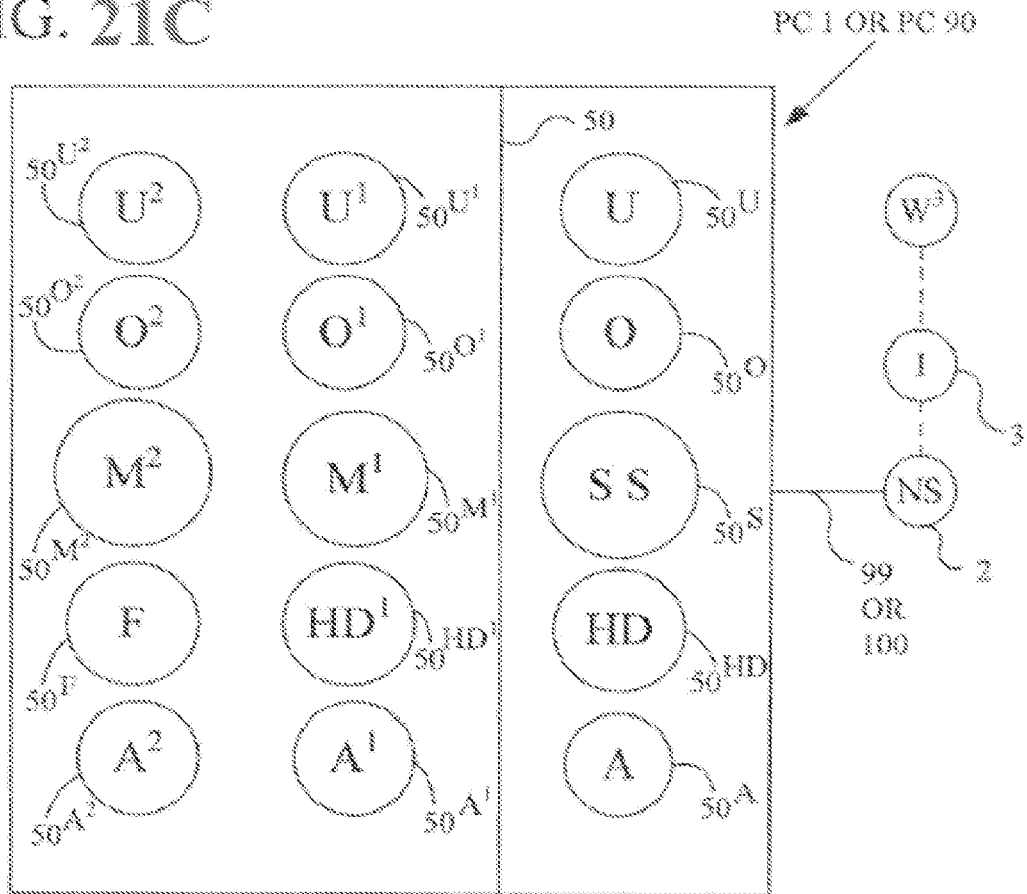

FIG. 21D

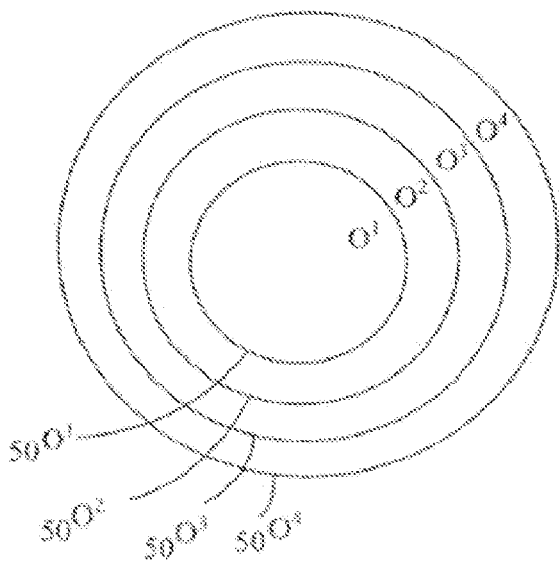
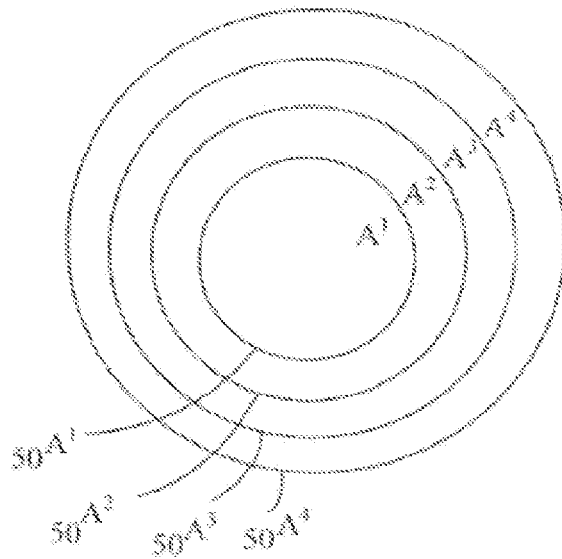

FIG. 21E



**COMPUTER OR MICROCHIP WITH A
SECURE SYSTEM BIOS HAVING A
SEPARATE PRIVATE NETWORK
CONNECTION TO A SEPARATE PRIVATE
NETWORK**

This application is a continuation of U.S. patent application Ser. No. 13/815,814, filed on Mar. 15, 2013, which is a continuation of U.S. patent application Ser. No. 13/398,403 filed on Feb. 16, 2012 which claims priority to U.S. Provisional Patent Application 61/457,184, filed Feb. 15, 2011; U.S. Provisional Patent Application No. 61/457,297, filed Feb. 18, 2011; U.S. Provisional Patent Application No. 61/457,976, filed Jul. 26, 2011; U.S. Provisional Patent Application No. 61/457,983, filed Jul. 28, 2011; U.S. Provisional Patent Application No. 61/573,006, filed Aug. 2, 2011; and U.S. Provisional Patent Application No. 61/573,007, filed Aug. 3, 2011.

This application is also a continuation-in-part of U.S. application Ser. No. 13/014,201, filed Jan. 26, 2011. U.S. application Ser. No. 13/014,201 claims benefit to U.S. Provisional Patent Application No. 61/282,337 filed Jan. 26, 2010; U.S. Provisional Patent Application No. 61/282,378, filed Jan. 29, 2010; U.S. Provisional Patent Application No. 61/282,478, filed Feb. 17, 2010; U.S. Provisional Patent Application No. 61/282,503, filed Feb. 22, 2010; U.S. Provisional Patent Application No. 61/282,861, filed Apr. 12, 2010; U.S. Provisional Patent Application No. 61/344,018, filed May 7, 2010; and U.S. Provisional Patent Application No. 61/457,184, filed Jan. 24, 2011.

This application is also a continuation-in-part of U.S. application Ser. No. 13/016,527 filed Jan. 28, 2011. U.S. application Ser. No. 13/016,527 claims benefit to U.S. Provisional Patent Application No. 61/282,378, filed Jan. 29, 2010; U.S. Provisional Patent Application No. 61/282,478, filed Feb. 17, 2010; U.S. Provisional Patent Application No. 61/282,503, filed Feb. 22, 2010; U.S. Provisional Patent Application No. 61/282,861, filed Apr. 12, 2010; U.S. Provisional Patent Application No. 61/344,018, filed May 7, 2010; and U.S. Provisional Patent Application No. 61/457,184, filed Jan. 24, 2011.

This application is also a continuation-in-part of PCT Application No. PCT/US011/023028, filed Jan. 28, 2011. PCT Application No. PCT/US011/023028 claims benefit to U.S. Provisional Patent Application No. 61/282,378, filed Jan. 29, 2010; U.S. Provisional Patent Application No. 61/282,478, filed Feb. 17, 2010; U.S. Provisional Patent Application No. 61/282,503, filed Feb. 22, 2010; U.S. Provisional Patent Application No. 61/282,861, filed Apr. 12, 2010; U.S. Provisional Patent Application No. 61/344,018, filed May 7, 2010; and U.S. Provisional Patent Application No. 61/457,184, filed Jan. 24, 2011. PCT Application No. PCT/US011/023028 also claims benefit to U.S. application Ser. No. 13/014,201, filed Jan. 26, 2011.

This application is also a continuation-in-part of PCT Application No. PCT/US011/025257, filed Feb. 17, 2011. PCT Application No. PCT/US011/025257 claims the right to priority based on U.S. Provisional Patent Application No. 61/282,478, filed Feb. 17, 2010; U.S. Provisional Patent Application No. 61/282,503, filed Feb. 22, 2010; U.S. Provisional Patent Application No. 61/282,861, filed Apr. 12, 2010; U.S. Provisional Patent Application No. 61/344,018, filed May 7, 2010; and U.S. Provisional Patent Application No. 61/457,184, filed Jan. 24, 2011. PCT Application No. PCT/US011/025257 also claims the right to priority based on U.S. Nonprovisional patent application Ser. No. 13/014,201, filed

Jan. 26, 2011, and U.S. Nonprovisional patent application Ser. No. 13/016,527, filed Jan. 28, 2011.

The contents of all of these provisional and nonprovisional patent applications are hereby incorporated by reference in their entirety.

BACKGROUND

This invention relates to any computer of any form, such as a personal computer and/or microchip, that has an inner hardware-based access barrier or firewall that establishes a private unit that is disconnected from a public unit, the public unit being configured for a connection to a public network of computers including the Internet. In addition, the computer's private unit is configured for a separate connection to at least one non-Internet-connected private network for administration, management, and/or control of the computer and/or microchip, locally or remotely, by either a personal user or a business or corporate entity.

More particularly, this invention relates to a computer and/or microchip with an inner hardware-based access barrier or firewall separating the private unit that is not connected to the Internet from a public unit connected to the Internet, the private and public units being connected only by a hardware-based access barrier or firewall in the form of a secure, out-only bus or equivalent wireless connection. Even more particularly, this invention relates to the private and public units also being connected by an in-only bus (or equivalent wireless connection) that includes a hardware input on/off switch or equivalent signal interruption mechanism, including an equivalent circuit on a microchip or nanochip (or equivalent wireless connection). Still more particularly, this invention relates to the private and public units being connected by an output on/off switch or microcircuit or nanocircuit equivalent on the secure, out-only bus (or equivalent wireless connection).

In addition, this invention relates to a computer and/or microchip that is connected to a another computer and/or microchip, the connection between computers being made with the same hardware-based access barriers or firewalls including potentially any of the buses and on/off switches described in the preceding paragraph.

Finally, this invention relates to a computer and/or microchip with hardware-based access barriers or firewalls used successively between an outer private unit, an intermediate more private unit, an inner most private unit, and the public unit (or units), with each private unit potentially being configured for a connection to a separate private network. Also, Faraday Cage protection from external electromagnetic pulses for part or all of the computer and/or microchip can be provided.

By way of background, connecting computers to the Internet has immense and well known benefits today, but also has created overwhelming security problems that were not imagined when the basic architecture of modern electronic computers was developed in 1945, which was about twenty years before networks came into use. Even then, those first networks involved a very limited number of connected computers, had low transmission speeds between them, and the network users were generally known to each other, since most networks were relatively small and local.

In contrast, the number of computers connected to the Internet today is greater by a factor of many millions, broadband connection speeds are faster by a similar magnitude, the network connections stretch worldwide and connect to hundreds of thousands of bad actors whose identity is not easily or quickly known, if ever. Indeed, the Internet of today allows

the most capable criminal hackers direct access to any computer connected to the Internet. This inescapable reality of the Internet has created a huge and growing threat to military and economic security worldwide. At the same time, connection to the Internet has become the communication foundation upon which both the global economy and individual users depend every day.

In summary, then, computer connection to the Internet is mandatory in today's world, so disconnection is not a feasible option, given the existing global dependence on the Internet. But those unavoidable connections have created a seemingly inherent and therefore unsolvable security problem so serious that it literally threatens the world. So Internet connection today is both unavoidable and unavoidably unsafe.

Past efforts to provide Internet security have been based primarily on conventional firewalls that are positioned externally, physically and/or functionally, between the computer and an external network like the Internet. Such conventional firewalls provide a screening or filtering function that attempts to identify and block incoming network malware. But because of their functionally external position, conventional firewalls must allow entry to a significant amount of incoming traffic, so either they perform their screening function perfectly, which is an impossibility, or at least some malware unavoidably gets into the computer and just a single instance of malware can cause a crash or worse. Once the malware is in, the von Neumann architecture of current computers provides only software protection, which is inherently vulnerable to malware attack, so existing computers are essentially indefensible from successful attack from the Internet, which has provided an easy, inexpensive, anonymous, and effective means for the worst of all hackers worldwide to access any computer connected to it.

SUMMARY

Therefore, computers cannot be successfully defended without inner hardware or firmware-based access barriers or firewalls that, because of their internal position, can be designed much more simply to function as an access barrier or blockers rather than as general filters. This is a distinct difference. An Internet filter has to screen any network traffic originating from anywhere in the entire Internet, which is without measure in practical terms and is constantly, rapidly changing, an incredibly difficult if not impossible screening task. In contrast, an access barrier or blocker to an inner protected area of a computer can strictly limit access to only an exception basis. So, in simple terms, a conventional firewall generally grants access to all Internet traffic unless it can be identified as being on the most current huge list of ever changing malware; in contrast, an inner access barrier or blocker can simply deny access to all network traffic, with the only exception being a carefully selected and very short and conditioned list of approved and authenticated sources or types of traffic to which access is not denied.

Such a massively simpler and achievable access blocking function allowing for a much simpler and efficient mechanism for providing reliable security. Whereas a conventional but imperfect firewall requires extremely complicated hardware with millions of switches and/or firmware and/or software with millions of bits of code, the hardware-based access barriers described in this application require as little as a single simple one-way bus and/or another simple one-way bus with just a single switch and/or both simple buses, each with just a single switch. This extraordinarily tiny amount of hardware is at the absolute theoretical limit and cannot be less.

With this new and unique access denial approach, a computer and/or microchip can be simply and effectively defended from Internet malware attack with one or more hardware-based private, protected units (or zones or compartments) inside the computer. Similar to Java Sandboxes in terms of overall function, but far more effective because hardware-based. Any or all of these private units can be administered, managed, and/or controlled by a personal or corporate computer user through the use of one or more separate and more secure non-Internet private networks. By thus avoiding any connection whatsoever to the generally insecure public Internet, connection of the computer's private unit to the secure private network allows for all the well known speed, efficiency and cost effectiveness of network connection while still completely avoiding the incalculable risk of Internet connection.

Volatile memory like Flash that is read/write can function as inexpensive read-only memory (ROM) when located in the Private Unit(s) because can be protected by an access barrier or firewall against writing. Furthermore, it can even be protected against unauthorized reading, unlike ROM. Finally, it can be written to when authorized by the central controller to update an operating system or download an app, for example, again unlike ROM.

In addition, field programmable gate arrays can be used in the private and public units, as well as in the access barriers or firewalls, and can be securely controlled by the computer or microchip central controller through the secure control bus to actively change security and other configurations, thus providing for the first time a dynamic and proactive hardware defense against Internet malware attacks.

This application hereby expressly incorporates by reference in its entirety U.S. patent application Ser. No. 10/684,657 filed Oct. 15, 2003 and published as Pub. No. US 2005/0180095 A1 on Aug. 18, 2005 and U.S. patent application Ser. No. 12/292,769 filed Nov. 25, 2008 and published as Pub. No. US 2009/0200661 A1 on Aug. 13, 2009.

Also, this application hereby expressly incorporates by reference in its entirety U.S. patent application Ser. No. 10/802,049 filed Mar. 17, 2004 and published as Pub. No. US 2004/0215931 A1 on Oct. 28, 2004; U.S. patent application Ser. No. 12/292,553 filed Nov. 20, 2008 and published as Pub. No. US 2009/0168329 A1 on Jul. 2, 2009; and U.S. patent application Ser. No. 12/292,769 filed Nov. 25, 2008 and published as Pub. No. US 2009/0200661 A1 on Aug. 13, 2009.

Finally, this application hereby expressly incorporates by reference in its entirety U.S. Pat. No. 6,167,428 issued 26 Dec. 2000, U.S. Pat. No. 6,725,250 issued 20 Apr. 2004, U.S. Pat. No. 6,732,141 issued 4 May 2004, U.S. Pat. No. 7,024,449 issued 4 Apr. 2006, U.S. Pat. No. 7,035,906 issued 25 Apr. 2006, U.S. Pat. No. 7,047,275 issued 16 May 2006, U.S. Pat. No. 7,506,020 issued 17 Mar. 2009, U.S. Pat. No. 7,606,854 issued 20 Oct. 2009, U.S. Pat. No. 7,634,529 issued 15 Dec. 2009, U.S. Pat. No. 7,805,756 issued 28 Sep. 2010, and U.S. Pat. No. 7,814,233 issued 12 Oct. 2010.

Definitions and reference numerals are the same in this application as in the above incorporated '657, '769, '049 and '553 U.S. Applications, as well as in the above incorporated '428, '250, '141, '449, '906, '275, '020, '854, '529, '756, and '233 U.S. Patents.

BRIEF DESCRIPTION OF THE DRAWINGS

FIG. 1 shows any computer of any type or size or design, such as a personal computer **1** and/or microchip **90** (and/or **501**) or nanochip with an inner hardware-based access barrier or firewall **50** establishing a Private Unit (or zone or compart-

5

ment) **53** of the computer or microchip that is disconnected from a Public Unit (or zone or compartment) **54** that is connected to the generally insecure public Internet **3** (and/or another, intermediate network **2** that is connected to the Internet **3**). FIG. **1** also shows an example embodiment of the Private Unit **53** having at least one separate connection to at least one separate, more secure non-Internet-connected private network **52** for personal or local administration of a computer such as the personal computer **1** and/or microchip **90** (and/or **501**) and/or silicon wafer **1500** (or portion **1501**, **1502**, and/or **1503**), or graphene equivalent. The number and placement of the non-Internet-connected networks **52** and the use of active configuration of the connection is optional.

FIG. **2** shows an example embodiment similar to that shown in FIG. **1**, including a personal computer **1** and/or microchip **90** (and/or **501**) with an inner hardware-based access barrier or firewall **50** separating a Private Unit **53** disconnected from the Internet **3** and a Public Unit **54** connected to the Internet **3**, but with the Private Unit **53** and Public Unit **54** connected only by a hardware-based access barrier or firewall **50a**, for example in the form of a secure, out-only bus (or wire) or channel **55** (or in an alternate embodiment, a wireless connection, including radio or optical).

FIG. **3** is an example embodiment similar to that shown in FIG. **2**, but with the Private Unit **53** and Public Unit **54** connected by a hardware-based access barrier or firewall **50b** example that also includes an in-only bus or channel **56** that includes a hardware input on/off switch **57** or equivalent function signal interruption mechanism, including an equivalent functioning circuit on a microchip or nanochip.

FIG. **4** is a similar example embodiment to that shown in FIGS. **2** and **3**, but with Private Unit **53** and Public Unit **54** connected by a hardware-based access barrier or firewall **50c** example that also includes an output on/off switch **58** or microcircuit equivalent on the secure, out-only bus or channel **55**.

FIG. **5** shows an example embodiment of any computer such as a first personal computer **1** and/or microchip **90** (and/or **501**) that is connected to a second computer such as a personal computer **1** and/or microchip **90** (and/or **501**), the connection between computers made with the same hardware-based access barrier or firewall **50c** example that includes the same buses or channels with on/off switches or equivalents as FIG. **4**.

FIG. **6** shows an example embodiment of a personal computer **1** and/or microchip **90** (and/or **501**) similar to FIGS. **23A** and **23B** of the '657 application, which showed multiple access barriers or firewalls **50** with progressively greater protection, but with hardware-based access barriers or firewalls **50c**, **50b**, and **50a** used successively from an inner private unit **53**, to an intermediate more private unit **53**¹, and to an inner most private unit **53**², respectively; each Private Unit **53**, **53**¹, and **53**² has at least one separate connection to at least one separate private or limited-access network.

FIG. **7** shows a schematic illustration of a classic Von Neumann computer hardware architecture.

FIGS. **8-14** are additional architectural schematic embodiment examples of **48** the use of hardware-based access barriers or firewalls **50a**, **50b**, and **50c** to create multiple compartments, as well as secure control buses and Faraday Cages.

FIGS. **15** and **16** show a lock mechanism **51** in access barrier/firewall **50** that enables a highly controlled method of transferring data or code between computer or microchip units separated by **50**, such as between a Private Unit **53** and a Public Unit **54**.

6

FIG. **17A** shows a buffer zone **350** without circuitry in any process layer in the zone, which functions to prevent hidden backdoor connections between microchip (or computer) units separated by an access barrier/firewall **50**, such as between a Private Unit **53** and a Public Unit **54**; FIG. **17B** shows a cross section of the FIG. **17A** embodiment.

FIG. **18** is like FIG. **6**, but shows an embodiment with the central controller (C) positioned in Private Unit **53**¹ and a secondary controller (S) **32** in Private Unit **53**².

FIGS. **19** and **20** illustrate methods in accordance with the present disclosure.

FIGS. **21A-21E** show multiple firewalls **50** within a personal computer **1** or PC microchip **90**.

DETAILED DESCRIPTION OF EXAMPLE EMBODIMENTS

FIGS. **1-4**, **6**, **8-14** all show useful architectural example embodiments of any computer or microchip, including a personal computer **1** and/or microchip **90** (and/or **501**) or silicon wafer (or graphene equivalent) **1500** (wafer or wafer portion **1501**, **1502**, and/or **1503**), as described in FIGS. **19-26** and associated text of the '553 application, which are incorporated by reference herein); tablets, smartphones, servers (including blades) and cloud or supercomputer arrays are other well known examples of computers. The computer shown has an inner hardware-based access barrier or firewall **50** establishing a secure Private Unit (or zone or compartment) **53** that is directly controlled by a user **49** (local in this example) and disconnected by hardware-based access barrier or firewall **50** from a Public Unit (or zone or compartment) **54** that is connected to the open, public and generally insecure Internet **3** and/or another, intermediate network **2**; the connection of the computer **1** (and/or **90** and/or **501** and/or **1500** or **1501**, **1502**, or **1503**) to the network **2** and/or Internet **3** can be wired **99** or wireless **100**.

Hardware-based access barrier or firewall **50** (or **50a**, **50b**, or **50c**) as used in this application refers to an access barrier that includes one or more access barrier or firewall-specific hardware and/or firmware components. This hardware and/or firmware configuration is in contrast to, for example, a computer firewall common in the art that includes only software and general purpose hardware, such as an example limited to firewall-specific software running on the single general purpose microprocessor or CPU of a computer.

The Internet-disconnected Private Unit **53** includes a master controlling device (M or CC) **30** for the computer PC**1** (and/or a master controller unit **93** for the microchip **90** and/or **501**) that can include a microprocessor or processing unit and thereby take the form of a general purpose microprocessor or CPU, for one useful example, or alternatively only control the computer as a master controller **31** or master controller unit **93'** (with relatively little or no general purpose processing power compared to the processing units or cores of the computer or microchip being controlled). The user **49** controls the master controlling device **30** (or **31** or **93** or **93'**) located in the Private Unit **53** and controls both the Private Unit **53** at all times and any part or all of the Public Unit **54** selectively, but can peremptorily control any and all parts of the Public Unit **54** at the discretion of the user **49** through active intervention or selection from a range of settings, or based on standard control settings by default, using for example a secure control bus **48** (to be discussed later). The Public Unit **54** typically can include one or more cores or general purpose microprocessors **40** or **94** and/or graphics-based microprocessors **68** or **82** that are designed for more general operations and not limited to graphics-related operations, including very large

numbers of either or both types of microprocessors, and potentially including one or more secondary controllers 32, as well as any number of specialized or single-function microprocessors.

The inner hardware-based access barrier or firewall has the capability of denying access to said protected portion of the computer 1 or microchip 90 by a generally insecure public network including the Internet, while permitting access by any other computer in the public network including the Internet to said one or more of the processing units included in the unprotected portion of the computer 1 or microchip 90 for an operation with said any other computer in the public network including the Internet when the computer is connected to the public network including the Internet. The operation can be any computer operation whatsoever involving some interaction between two computers including simply sending and/or receiving data and also including, but not limited to, specific examples such as searching, browsing, downloading, streaming, parallel processing, emailing, messaging, file transferring or sharing, telephoning or conferencing.

More particularly, FIG. 1 shows a useful example of an optional (one or more) private network 52, which is more secure by being, for example, closed and disconnected from the Internet 3 (permanently or temporarily) and/or by having controlled access, to be used for administration and/or management and/or control of the Private Unit 53, including for example by a business enterprise. Wired 99 connection directly to the Private Unit 53 offers superior security generally for the closed and secure private network 52, but wireless 100 connection is a option, especially if used with a sufficiently high level of encryption and/or other security measures, including low power radio signals of high frequency and short range and/or directional, as well as frequency shifting and other known wireless security measures. Access from the private non-Internet-connected network 52 can be limited to only a part of the Private Unit 53 or to multiple parts or to all of the Private Unit 53.

FIG. 1 shows a computer 1 and/or microchip 90 (and/or 501 and/or 1500, 1501, 1502, or 1503) with the at least one Public Unit 54 and the at least one Private Unit 53. The at least one Public Unit 54 is configured for connection to the Internet 3, either directly or through at least one intermediate network 2. The at least one Private Unit 53 is disconnected from the networks 2 and 3 by the access barrier/firewall 50 and is connected to only a private network 52 from a network connection location in the Private Unit 53. The Public Unit 54 is connected to network 2 and/or 3 from a separate network connection location in the Public Unit 54. Separate and distinct network connection components 98 for separate wired 99 and/or wireless 100 network connections are shown at the at least two separate and distinct network connection locations, one location in the Private Unit (or units) 53 and the other location in Public Unit 54 indicated in FIG. 1 and FIGS. 2-11, 12-14 and 18.

Such a one or more private non-Internet-connected network 52 (not connected to the open and insecure public Internet 3 either directly or indirectly, such as through another, intermediate network like an Intranet 2) can allow specifically for use as a highly secure and closed private network for providing administrative or management or control functions like testing, maintenance, trouble-shooting, synchronizing files, modifying security, or operating or application system updates to the Private Units 53 of any computers (PC1 or microchip 90 or 501) with one or more Public Units 54 that are connected to a less secure local network 2, such as a business or home network, that is connected to the public Internet 3.

A particularly useful business example would be administering large numbers of local employee personal computers or network servers, and also including large arrays (especially blades) for cloud applications or supercomputer arrays with a vast multitude of microprocessors or local clusters; in the latter examples, it is possible for a centralized operator to use the private network 52 to control, securely and directly, the master controlling devices 30 or 31 or master controller unit 93 or 93' and associated memory or other devices in the Private Units 53 of a multitude of servers, blades, or large arrays or clusters of computers that are connected to the Internet 3. A personal use example would be to use a private network 52 to connect the private unit 53 of a personal user's smartphone to the private unit 53 of the user's computer laptop in order to update and/or synchronize data or code between the two private units 53. To maximize security, some or all network 52 traffic can be encrypted and/or authenticated, especially if wireless 100, including with a very high level of encryption.

In addition, in another useful example, a computer (PC1 and/or 90 and/or 501) can be configured so that the private non-Internet-connected network 52 can have the capability to allow for direct operational control of the Private Unit 53, and thus the entire computer, from any location (including a remote one), which can be useful for example for businesses operating an array of servers like blades to host cloud operations or supercomputers with large numbers of microprocessors or cores.

One or more access barriers or firewalls 50a, 50b, or 50c can be located between the secure private non-Internet-connected network 52 and the Private Unit 53, providing a useful example of increased security that can be controlled using the private network 52.

In yet another useful example, a personal user 49 can dock his smartphone (PC1 and/or 90 and/or 501 and/or 1500, 1501, 1502, or 1503) linking through wire or wirelessly to his laptop or desktop computer (PC1 and/or 90 and/or 501 and/or 1500, 1501, 1502, or 1503) in a network 52 connection to synchronize the Private Units 53 of those two (or more) personal computers or perform other shared operations between the Private Units 53. In addition, the Public Units 54 of the user's multiple personal computers can be synchronized simultaneously during the same tethering process, or perform other shared operations between the Public Units 54. Other shared operations can be performed by the two or more linked computers of the user 49 utilizing, for example, two or three or more Private Units 53, each unit with one or more private non-Internet connected networks 52, while two or more Public Units 54 can perform shared operations using one or more other networks 2, including the open and insecure Internet 3, as shown later in FIG. 6.

Also shown in FIG. 1 for personal computer PC1 embodiments is an optional removable memory 47 located in the Private Unit 53; the removable memory 47 can be of any form or type or number using any form of one or more direct connections to the Private Unit 53; a thumbdrive or SD card are typical examples, connected to USB, Firewire, SD, or other ports located in the Private Unit 53 (or other ports or card slots of any form), which can also be used for the physical connection to the private network 52. FIG. 1 shows as well an optional one or more removable keys 46, of which an access key, an ID authentication key, or an encryption and/or decryption key are examples, also connected to the Private Unit 53 using any form of connection, including the above examples; both 46 and 47 can potentially be isolated from other parts of the Private Unit 53 by access barrier(s) or

firewall(s) **50**, **50a**, **50b**, and/or **50c**, which can use active configuration such as field programmable gate array(s) **59**.

For microchip **90** (and/or **501**) embodiments, wireless connection is a feasible option to enable one or more removable memories **47** or one or more removable keys **46** (or combination of both), particularly for ID authentication and/or access control, utilizing the same ports described above. In addition, all or part of the Private Unit **53** of a computer **PC1** and/or microchip **90** and/or **501** (or wafer **1500**, **1501**, **1502**, or **1501**) can be removable from the remaining portion of the same computer **PC1** and/or microchip **90** and/or **501**, including the Public Unit **54**; the access control barrier or firewall **50** (or **50a** and/or **50b** and/or **50c**) can be removable with the Private Unit **53** or remain with Public Unit **54**.

Finally, FIG. **1** shows schematically within the dashed lines indicated the potential use anywhere in (and in any hardware component of) computer **1** and/or microchip **90** (and/or **501** and/or **1500**, **1501**, **1502**, or **1503**) of a field programmable gate array or arrays (FPGA) **59** (or other means of active hardware configuration), including in the Private Unit **53**, the Public Unit **54**, or the access barriers or firewalls **50**, **50a**, **50b**, and/or **50c** that are shown in FIGS. **2-6** and later figures, and including any such barriers or firewalls located between the Private Unit **53** and either the secure private network **52** as shown in FIG. **1** or networks **52**, **52¹**, or **52²** as shown in FIG. **6**, for example. The field programmable gate array(s) **59** can be controlled by the master controlling device **30** or **93** or **31** or **93*** using a secure control bus **48**, as discussed and shown later in this application. By using FPGA **59** thus controlled securely by the central controller, the access barrier(s) or firewall(s) can be changed at any time, such as from **50a** to **50b** or **50c** or any other change (these new access barriers or firewalls will be discussed in later figures), for example. In addition, FPGA **59** can also change, for example, any of the circuitry in the Private Unit **53** of computer **1** or microchip **90** or **501** (or any other part) while keeping any new such hardware configuration from view or control of any network intruders that may have gained access to the Public Unit **54**. Similarly, the FPGA **59** in the Public Unit **54** can be controlled to show one hardware configuration for a while and then securely change it to any other hardware configuration (such as altering access to ports or network connections, for example), either randomly or proactively or in response to a malware attack, by rebooting the new hardware configuration under control of the secure central controlling device in the Private Unit **53** of the microchip or computer and using the secure control bus **48**. In this way, a secure dynamic and proactive hardware defense for computers and microchips is possible for the first time. Other useful examples of the potential for use anywhere in computers **1** and/or microchips **90** (and/or **501** and/or **1500**, **1501**, **1502**, or **1503**) of a field programmable gate array or arrays (FPGA) **59** (or other means of active hardware configuration) is shown schematically in FIGS. **6**, **9**, and **11-17** and can be used in a similar way in FIGS. **2-6** as well.

FIG. **2** shows an example embodiment that, in terms of communication between the two Units, the Private Unit **53** and Public Unit **54** are connected only by an inner hardware-based access barrier or firewall **50a** in the form of a secure, out-only bus (or wire) or channel **55** that transmits data or code that is output from the Private Unit **53** to be input to the Public Unit **54**. The user **49** controls the Private Unit **53**-located master controlling device **30** (or **31** or **93** or **93'**), which controls all traffic on the secure out-only bus or channel **55**. Connections between the user **49** and the master controlling device **30** (or **31** or **93** or **93'**), as well as between the master controlling device **30** (or **31** or **93** or **93'**) and any component

controlled by it, can be for example hardwired on a motherboard (and/or executed in silicon on a microchip **90** and/or **501**) to provide the highest level of security.

In the example shown in FIG. **2**, there is no corresponding in-only bus or channel **56** transmitting data or code that is output from the Public Unit **54** to be input to the Private Unit **53**. By this absence of any bus or channel into the Private Unit **53**, all access from the Internet **3** or intervening network **2** to the Private Unit **53** is completely blocked on a permanent basis. Another example is an equivalent wireless connection between the two Units would require a wireless transmitter (and no receiver) in the Private Unit **53** and a receiver (and no transmitter) in the Public Unit **54**, so the Private Unit **53** can only transmit data or code to the Public Unit **54** and the Public Unit **54** can only receive data or code from the Private Unit **53** (all exclusive of external wireless transmitters or receivers of the **PC1** and/or microchip **90** and/or **501**).

The Private Unit **53** can include any non-volatile memory, of which read-only memory and read/write memory of which flash memory (and hard drives and optical drives) are examples, and any volatile memory, of which DRAM (dynamic random access memory) is one common example.

An equivalent connection, such as a wireless (including radio and/or optical) connection, to the out-only bus or channel **55** between the two Units **53** and **54** would require at least one wireless transmitter in the Private Unit **53** and at least one receiver in the Public Unit **54**, so the Private Unit **53** can transmit data or code to the Public Unit **54** only (all exclusive of external wireless transmitters or receivers of the **PC1** and/or microchip **90** and/or **501**).

An architecture for any computer or microchip (or nanochip) can have any number of inner hardware-based access barriers or firewalls **50a** arranged in any configuration.

FIG. **2** also shows an example embodiment of a firewall **50** located on the periphery of the computer **1** and/or microchip **90** (and/or **501**) controlling the connection between the computer and the network **2** and Internet **3**; the firewall **50** can be hardware-controlled directly by the master controlling device **30** (or **31** or **93** or **93'**), for example.

FIG. **3** is a similar useful architectural example embodiment to that shown in FIG. **2**, but with the Private Unit **53** and Public Unit **54** connected in terms of communication of data or code by an inner hardware-based access barrier or firewall **50b** example that includes a secure, out-only bus or channel **55**. The connection between units also includes an in-only bus or channel **56** that is capable of transmitting data or code that is output from the Public Unit **54** to be input into the Private Unit **53**, strictly controlled by the master controller **30** (and/or **31** and/or **93** and/or **93'**) in the Private Unit **53**. The in-only bus or channel **56** includes an input on/off switch (and/or microchip or nanochip circuit equivalent) **57** that can break the bus **56** Public to Private connection between Units, the switch **57** being controlled by the Private Unit **53**-located master controlling device **30** (or **31** or **93** or **93'**), which also controls all traffic on the in-only bus or channel **56**; the control can be hardwired.

For one example, the master controller **30** (or **31** or **93** or **93'**) can by default use the on/off switch and/or micro-circuit (or nano-circuit) equivalent **57** to break the connection provided by the in-only bus or channel **56** to the Private Unit **53** from the Public Unit **54** whenever the Public Unit **54** is connected to the Internet **3** (or intermediate network **2**). In an alternate example, the master controller **30** (or **31** or **93** or **93'**) can use the on/off switch and/or micro or nano-circuit equivalent **57** to make the connection provided by the in-only bus or channel **56** to the Private Unit **53** only when very selective criteria or conditions have been met first, an example of which

11

would be exclusion of all input except when encrypted and from one of only a few authorized (and carefully authenticated) sources, so that Public Unit 54 input to the Private Unit 53 is extremely limited and tightly controlled from the Private Unit 53.

Another example is an equivalent connection, such as a wireless (including radio and/or optical) connection, to the in-only bus or channel 56 with an input on/off switch 57 between the two Units 53 and 54 would require at least one wireless receiver in the Private Unit 53 and at least one transmitter in the Public Unit 54, so the Private Unit 53 can receive data or code from the Public Unit 54 while controlling that reception of data or code by controlling its receiver, switching it either "on" when the Public Unit 54 is disconnected from external networks 2 and/or 3, for example, or "off" when the Public Unit 54 is connected to external networks 2 and/or 3 (all exclusive of external wireless transmitters or receivers of the PC1 and/or microchip 90 and/or 501).

An architecture for any computer and/or microchip (or nanochip) can have any number of inner hardware-based access barriers or firewalls 50b arranged in any configuration.

FIG. 4 is a similar useful architectural example embodiment to that shown in FIGS. 2 and 3, but with Private Unit 53 and Public Unit 54 connected in terms of communication of data or code by an inner hardware-based access barrier or firewall 50c example that also includes an output on/off switch and/or microcircuit equivalent 58 on the secure out-only bus or channel 55, in addition to the input on/off switch and/or microcircuit (or nano-circuit) equivalent 57 on the in-only bus or channel 56.

The output switch or microcircuit equivalent 58 is capable of disconnecting the Public Unit 54 from the Private Unit 53 when the Public Unit 54 is being permitted by the master controller 30 (or 31 or 93 or 93') to perform a private operation controlled (completely or in part) by an authorized third party user from the Internet 3, as discussed previously by the applicant relative to FIG. 17D and associated textual specification of the '657 application incorporated above. The user 49 using the master controller 30 (or 31 or 93 or 93') always remains in preemptive control on the Public Unit 54 and can at any time for any reason interrupt or terminate any such third party-controlled operation. The master controller 30 (or 31 or 93 or 93') controls both on/off switches 57 and 58 and traffic (data and code) on both buses or channels 55 and 56 and the control can be hardwired.

Another example is an equivalent connection, such as a wireless connection, to the in-only bus or channel 56 and out-only bus or channel 55, each with an on/off switch 57 and 58 between the two Units 53 and 54, would require at least one wireless transmitter and at least one receiver in the Private Unit 53, as well as at least one transmitter and at least one receiver in the Public Unit 54, so the Private Unit 53 can send or receive data or code to or from the Public Unit 54 by directly controlling the "on" or "off" state of its transmitter and receiver, controlling that flow of data or code depending, for example on the state of external network 2 or Internet 3 connection of the Public Unit 54 (again, all exclusive of external wireless transmitters or receivers of the PC1 and/or microchip 90 and/or 501).

The buses 55 and/or 56 can be configured to transport control and/or data and/or code between the Units (or any components thereof) of a computer and/or microchip; and there can be separate buses 55 and/or 56 for each of control and/or data and/or code, or for a combination of two of control or data or code.

12

An architecture for any computer and/or microchip (or nanochip) can have any number of inner hardware-based access barriers or firewalls 50c arranged in any configuration.

FIG. 5 shows an architectural example embodiment of a first computer (personal computer 1 and/or microchip 90 and/or 501 or wafer 1500, or 1501, 1502, or 1503) functioning as a Private Unit 53' that is connected to at least a second computer (or to a multitude of computers, including personal computers 1 and/or microchips 90 and/or 501 or 1500, 1501, 1502, or 1503) functioning as a Public Unit or Units 54'. The connection between the private computer 53' and the public computer or computers 54' is made including the same inner hardware-based access barrier or firewall 50c architecture that includes the same buses and channels 55 and 56 with the same on/off switches 57 and 58 as previously described above in the FIG. 4 example above and can use the same hardware control. Alternatively, inner hardware-based access barriers or firewalls 50a or 50b can be used. In addition, inner hardware-based access barriers or firewalls 50a, 50b, and 50c can be used within the first and/or second computers.

The connection between the first and second computer can be any connection, including a wired network connection like the Ethernet, for example, or a wireless network connection, similar to the examples described above in previous FIGS. 2-4. In the Ethernet example, either on/off switch 57 or 58 can be functionally replaced like in a wireless connection by control of an output transmitter or an input receiver on either bus or channel 55 or 56; the transmitter or receiver being turned on or off, which of course amounts functionally to mere locating the on/off switches 55 or 56 in the proper position on the bus or channel 55 or 56 to control the appropriate transmitter or receiver, as is true for the examples in previous figures.

FIG. 6 shows a useful architectural example embodiment of any computer (a personal computer 1 and/or microchip 90 and/or 501 or wafer 1500, 1501, 1502, or 1503) similar to FIGS. 23A and 23B of the '657 application incorporated by reference above, which showed multiple inner firewalls 50 with progressively greater protection. FIG. 6 shows an example of an internal array of inner hardware-based access barriers or firewalls 50c, 50b, and 50a (described in previous FIGS. 2-4 above) used in a specific sequence between a public unit 54 and a first private unit 53, between the first private unit 53 and a more private second unit 53¹, and between the more private second unit 53¹ and a most private third unit 53², respectively.

In addition, FIG. 6 shows a useful architectural example embodiment of one or more master controllers C (30 or 93) or master controllers-only (31 or 93') located in the most private unit 53², with one or more microprocessors or processing units or "cores" S (40 or 94) (and/or 68 or 82) located in the more private unit 53¹, in the private unit 53, and in the public unit 54. Each of the microprocessors or processing units or cores S can have at least one secondary controller 32 with which it can be integrated, for example.

The microprocessors S (or processing units or cores) can be located in any of the computer units, but the majority in a many core architecture can be in the public unit to maximize sharing and Internet use. Alternatively, for computers that are designed for more security-oriented applications, a majority of the microprocessors S (or processing units or cores) can be located in the private units; any allocation between the public and private units is possible. Any other hardware, software, or firmware component or components can be located in the same manner as are microprocessors S (or master controllers-only C) described above.

The one or more master controlling device (M) **30** or master controller unit **93** (or **31** or **93'**), sometimes called the central controller (CC) or central processing unit (CPU), can be usefully located in any Private Unit **53**, including for example as shown in FIG. 6 in Private Unit **53²**, or in Private Units **53¹** or **53**, such as utilizing one of the secondary controllers (S) **32** (**40** or **94**) as the master controller (M or CC), either on a permanent or temporary basis. Particularly on a temporary basis, the master controller (M or CC) can move from one location to another, such as moving from a less private unit **53** to a more private Unit **53¹** or to a most private Unit **53²** in response for example to an increased level in the threat environment or to a direct malware attack, respectively. Such movement can be effected simply by designation or assignment by a user **49** or through the Private Network **52**, for example. It is even possible to locate the master controller (M or CC) in at least part of the Public Unit **54**, including for example when it has its own access barrier or firewall **50** (including **50a**, **50b**, and/or **50c**), as shown in FIG. 13, and/or when booted in a controlled manner from a Private Unit **53**, on a temporary or permanent basis, such as for example when used in a particularly secure environment. Such movement of M or CC noted above can also be effected by field programmable gate array or arrays (FPGA) or another form of active hardware configuration. The existing increasing use of multiple or many microprocessors in computers from smartphones to huge server arrays and supercomputers, in the form of multiple or many processor (CPU) microchips and/or in the form of multiple or many "cores" on a processor microchip, facilitates the easy movement of the master or central controller (M or CC) within a computer **1** and/or microchip **90** (and/or **501** and/or **1500**, **1501**, **1502**, or **1503**), since the M or CC can easily be moved from one general purpose processor microchip to another and/or from one general purpose core to another (and/or potentially between hybrid graphics microchips or cores). FIG. 18 is like FIG. 6, but shows an example embodiment with the central controller (C) positioned in Private Unit **53¹** and a secondary controller (S) **32** in Private Unit **53²**, temporarily or permanently.

An architecture for any computer and/or microchip or nanochip can have any number of inner hardware-based access barriers or firewalls **50a** and/or **50b** and/or **50c** arranged in any combination or configuration.

As shown in FIG. 6, the private non-Internet network **52**, which was discussed previously relative to FIG. 1, can consist in an example embodiment of more than one network, with each additional non-Internet network **52** being used to connect Private Units **53²**, **53¹**, and **53** of one computer and/or microchip to separate non-Internet networks **52²**, **52¹** and **52**, respectively, and that are connected to Private Units **53²**, **53¹**, and **53**, respectively, of other computers and/or microchips. That is, each computer and/or microchip Private Unit **53²**, **53¹**, and **53** can have its own separate, non-Internet network **52²**, **52¹**, and **52**, respectively, and so that any Private Unit can be connected to other computer PC1 and/or microchip **90** (and/or **501**) units of the same level of security; any Private Unit can also be subdivided into subunits of the same level of security. This is a useful embodiment example for making relatively local connections from business or home networks and scales up to large business servers, cloud, or supercomputers applications. The connections can be wired or wireless and local or non-local.

Similarly, a computer PC1 and/or microchip **90** or **501** Public Unit **54** can be subdivided into a number of different levels of security, for example, and each subdivided Public Unit **54** can have a separate, non-Internet connected network **52**; and a subdivided Public Unit **54** can be further subdivided

with the same level of security. In addition, any hardware component (like a hard drive or Flash memory device (and associated software or firmware), within a private (or public) unit of a given level of security can be connected by a separate non-Internet network **52** to similar components within a private (or public) unit of the same level of security.

Any configuration of access barriers or firewalls **50a** and/or **50b** and/or **50c** can be located between any of the private non-Internet-connected networks **52²**, **52¹**, and **52**, and the Private Units **53²**, **53¹**, and **53**, respectively, providing a useful example of increased security control as shown in FIG. 6.

Also shown in the example embodiment of FIG. 6, each Private Unit **53²**, **53¹**, and **53** can have one or more ports (or connections to one or more ports), like for a USB connection to allow for the use of one or more optional removable access and/or encryption or other keys **46**, and/or one or more optional removable memory (such as a USB Flash memory thumbdrive) or other device **47**, both of which as discussed previously in the text of FIG. 1, which example can also have one or more ports for either **46** and/or **47** and/or other device. The Public Unit **54** can also have one or more of any such removable devices, or ports like a USB port to allow for them.

Any data or code or system state, for example, for any Public or Private Unit **54** or **53** can be displayed to the personal user **49** and can be shown in its own distinctive color or shading or border (or any other visual or audible distinctive characteristic, like the use of flashing text). FIG. 6 shows an example embodiment of different colors indicated for each of the Units.

For embodiments requiring a higher level of security, it may be preferable to eliminate permanently or temporarily block (by default or by user choice, for example) the non-Internet network **52²** and all ports or port connections in the most private unit **53²**.

The public unit **54** can be subdivided into an encrypted area (and can include encryption/decryption hardware) and an open, unencrypted area, as can any of the private units **53**; in both cases the master central controller **30**, **31**, **93**, or **93'** can control the transfer of any or all code or data between an encrypted area and an unencrypted area considering factors such authentication.

Finally, FIG. 6 shows the potential use anywhere in computers **1** and/or microchips **90** (and/or **501** and/or **1500**, **1501**, **1502**, or **1503**) of a field programmable gate array or arrays (FPGA or other means of active hardware configuration) **59**, as described under FIG. 1.

The invention example structural and functional embodiments shown in the above described FIGS. 1-6, as well as the following FIGS. 7-16 and the associated textual specification of this application all most directly relate to the example structural and functional embodiments of the inner firewall **50** described in FIGS. 10A-10D, 10J-10Q, 17A-17D, 23A-23E, 24, 25A-25D and 27A-27G, and associated textual specification, of the above '657 application incorporated by reference.

FIG. 7 shows the fundamental security problem caused by the Internet connection to the classic Von Neumann computer hardware architecture that was created in 1945. At that time there were no other computers and therefore no networks of even the simplest kind, so network security was not a consideration in its fundamental design, which is unsafe for use when connected to an open insecure public network of enormous scale, such as the Internet.

FIGS. 8-14 are useful architectural example embodiments of the inner hardware-based access barriers or firewalls **50a**, **50b**, and **50c**.

FIG. 8 shows a useful example embodiment of the applicant's basic architectural solution to the fundamental security

15

problem caused by the Internet, the solution being to protect the central controller of the computer with an inner firewall **50** controlling access by the Internet, as discussed in detail in FIGS. 10A-10D and 10J-10Q, and associated textual specification of the '657 application, those specific drawing and text portions of which are incorporated by reference in this application; they were discussed as well as earlier in this application. FIG. **8** and subsequent figures describe example embodiments of a number of specific forms of an inner hardware-based access barrier or firewall **50**, such as access barriers or firewalls **50a** and/or **50b** and/or **50c** as described previously in this application; the number and potential configurations of access barriers or firewalls **50a** and/or **50b** and/or **50c** within any computer, such as computer PC **1** and/or microchip **90** (and/or **501**) is without any particular limit.

FIG. **9** is a similar embodiment to FIG. **8**, but also showing a useful architectural example of a central controller integrated with a microprocessor to form a conventional general purpose microprocessor or CPU (like an Intel x86 microprocessor, for example). FIG. **8** also shows a computer PC **1** and/or microchip **90** and/or **501** with many microprocessors or cores.

Finally, FIG. **9** shows the potential use anywhere in computers **1** and/or microchips **90** (and/or **501** and/or **1500**, **1501**, **1502**, or **1503**) of a field programmable gate array or arrays (FPGA) **59** (or other means of active hardware configuration), as described under FIG. **1**.

FIG. **10** is the same embodiment as FIG. **9**, but also shows a major functional benefit of the applicant's access barrier or firewall **50a**, **50b**, and **50c** invention, which is to enable a function to flush away Internet malware by limiting the memory access of malware to DRAM **66** (dynamic random access memory) in the Public Unit **54**, which is a useful example of a volatile memory that can be easily and quickly erased by power interruption. The flushing function use of a firewall **50** was discussed earlier in detail in FIGS. 25A-25D and associated textual specification of the '657 application and those specific drawing and text portions of the '657 application are incorporated by reference herein. After being flushed, the Public Unit **54** can be rebooted from the Private Unit **53** by the central controller using the secure control bus **48** to be discussed and shown later.

FIG. **11** is a useful example embodiment similar to FIG. **6** and shows that any computer or microchip can be partitioned into many different layers of public units **54** and private units **53** using an architectural configuration of access barriers or firewalls **50a**, **50b**, and **50c**; the number and arrangement of potential configurations is without any particular limit; and the number of microprocessors **40** or **94** and/or **68** or **82** in the public unit **53** can be potentially any number, including 1 or 2 or 3 or at least 4 or 8 or 16 or 32 or 64 or 128 or 256 or 512 or 1024 or many more, as could potentially be the case in prior or subsequent figures. The partition architecture provided by firewalls **50** was discussed earlier in detail in FIGS. 23A-23B and associated textual specification of the '657 application and those specific drawing and text portions are incorporated by reference herein.

Finally, FIG. **11** shows the potential use anywhere in computers **1** and/or microchips **90** (and/or **501** and/or **1500**, **1501**, **1502**, or **1503**) of a field programmable gate array or arrays (FPGA) **59** (or other means of active hardware configuration), as described under FIG. **1**.

FIG. **12** is another useful architectural example embodiment of the layered use of access barriers or firewalls **50**, **50a**, **50b**, and **50c** based on a kernel or onion structure; the number of potential configurations including relative to layers or

16

types of access barriers or firewalls is without any particular limit. This structure was discussed in detail relative to firewalls **50** in FIGS. 23D-23E and associated textual specification of the '657 application and those specific drawing and text portions are incorporated by reference herein.

FIG. **12** also shows the potential use anywhere in computers **1** and/or microchips **90** (and/or **501** and/or **1500**, **1501**, **1502**, or **1503**) of a field programmable gate array or arrays (FPGA) **59** (or other means of active hardware configuration), as described under FIG. **1**.

FIG. **13** is a useful architectural example embodiment showing the presence of many FIG. **12** example embodiments with layered access barriers or firewalls **50a**, **50b**, and **50c** structures on all of the many hardware, software, and/or firmware components of a computer; the number of FIG. **12** embodiments or their potential configurations including relative to layers or types of access barriers or firewalls is without any particular limit in either the private unit **53** or the public unit **54** of any computer or microchip. The many layered kernels structure was discussed in more detail in FIG. 23C and associated textual specification of the '657 application and those specific drawing and text portions are incorporated by reference earlier. Note that any subcomponent or kernel of the FIG. **12** example embodiment can be protected by a hardware-based access barrier **50a** (or **50b** or **50c** or **50**), a secure, out-only bus or channel **55**, and therefore can for example be effectively disconnected from any input from any network, including either the secure private network **52** and the insecure public network including the Internet **3**.

FIG. **13** shows the potential use anywhere in computers **1** and/or microchips **90** (and/or **501** and/or **1500**, **1501**, **1502**, or **1503**) of a field programmable gate array or arrays (FPGA) **59** (or other means of active hardware configuration), as described under FIG. **1**.

FIG. **14** is a useful architectural example embodiment similar to FIG. **13**, but also showing the computer PC **1** and/or microchip **90** and/or **501** surrounded by a Faraday Cage **300**; the number of potential similar configurations is without any particular limit. This use of Faraday Cages **300** was discussed in detail in FIGS. 27A-27G and associated textual specification of the '657 application and those specific drawing and text portions are incorporated by reference herein.

FIG. **14** shows a useful example embodiment of a Faraday Cage **300** surrounding completely a computer PC **1** and/or microchip **90** and/or **501**. The Faraday Cage **300** can be subdivided by an example partition **301** to protect and separate the Private Unit **53** from the Public Unit **54**, so that the Private Unit **53** is completely surrounded by Faraday Cage **300**¹ and Public Unit **54** is completely surrounded by Faraday Cage **300**², in the example embodiment shown. Each unit can alternatively have a discrete Faraday Cage **300** of its own, instead of partitioning a larger Faraday Cage **300** and the surrounding of a Unit can be complete or partial. Any number or configuration of Faraday Cages can be used in the manner shown generally in FIG. **14**, including a separate Faraday Cage for any hardware component of the computer or microchip. The Faraday Cages can provide protection against an external electromagnetic pulse, including massive ones, and against external surveillance or internal surveillance including between private and public portions of a computer and/or microchip or nanochip.

Finally, FIG. **14** shows the potential use anywhere in computers **1** and/or microchips **90** and/or **1500**, **1501**, **1502**, or **1503** of a field programmable gate array or arrays (FPGA) **59** (or other means of active hardware configuration), as described under FIG. **1**.

The example embodiments shown in FIGS. 1-4, 6-11, and 13-19 are a computer of any sort, including a personal computer PC1; or a microchip 90 or 501, including a microprocessor or a system on a chip (SoC) such as a personal computer or a microchip 90; or a combination of both, such as a computer with the architecture shown in FIGS. 1-4, 6-11, and 13-19, the computer also including one or more microchips also with the architecture shown in FIGS. 1-4, 6-11, and 13-19.

The Public Unit 54 shown in FIGS. 1-6, 8-11, and 13-17 can be used in a useful embodiment example to run all or a part of any application (or "apps") downloaded from the Internet or Web, such as the example of any of the many thousands of apps for the Apple iPhone that are downloaded from the Apple Apps Store, or to run applications that are streamed from the Internet or Web. Similarly, all or part of a video or audio file like a movie or music that would otherwise be protected by digital management rights can be downloaded or streamed from the Web and played in the Public Unit 54 for viewing and/or listening by the computer user 49, while at the same time that user 49 has no control over the Public Unit 54 to copy the protected files since he can be denied access to those functions during the download or streaming.

Some or all personal data pertaining to a user 49 can be kept exclusively on the user's computer PC1 and/or microchip 90 and/or 501 for any cloud application or app to protect the privacy of the user 49 (or kept non-exclusively as a back-up), unlike conventional cloud apps, where the data of a personal user 49 is kept in the cloud. In existing cloud architectures, user data is separated and protected only by software, not hardware, and there can be potentially shared intentionally or carelessly compromised without authorization by or knowledge of the personal user 49. In effect, the Public Unit 54 can function as a safe and private local cloud, with personal files can be operated on there using cloud apps downloaded from a cloud web site and those personal files can be retained in the Private Unit 53 after the operation is completed. All or part of an app can also potentially be downloaded or streamed to one or more Private Units, including 53², 53¹, and 53, and retained or used for local operations either in the Private Unit or in a Public Unit, in the manner that apps are currently.

Privacy in conventional clouds can also be significantly enhanced using the inner hardware-based access barriers or firewalls 50a and/or 50b and/or 50c described in this application, since each individual or corporate user of the cloud can be assured that their data is safe because it can be physically separated and segregated by hardware, instead of by software alone, as is the case currently.

Similarly, the example embodiment of FIG. 6 shows a computer and/or microchip Public Unit 54 and Private Units 53, 53¹, and 53², each with a separate Faraday Cage. 300⁴, 300³, 300², and 300¹, respectively, that are create using partitions 301^c, 301^b, and 301^a, respectively. Any Public Unit 54 or Private Unit 53 can be protected by its own Faraday Cage 300. The Faraday Cage 300 can completely or partially surround the any Unit in two or three dimensions.

FIGS. 8-11 and 13-14 also show example embodiments of a secure control bus (or wire or channel) 48 that connects the master controlling device 30 (or 31) or master control unit 93 (or 93') or central controller (as shown) with the components of the computer PC1 and/or microchip 90 and/or 501, including those in the Public Unit 54. The secure control bus 48 provides hardwired control of the Public Unit 54 by the central controller in the Private Unit 53. The secure control bus 48 can be isolated from any input from the Internet 3 and/or an intervening other network 2 and/or from any input or monitoring from any or all parts of the Public Unit 54. The secure

control bus 48 can provide and ensure direct preemptive control by the central controller over any or all the components of the computer, including the Public Unit 54 components. The secure control bus 48 can, partially or completely, coincide or be integrated with the bus 55, for example. The secure control bus 48 is configured in a manner such that it cannot be affected, interfered with, altered, read or written to, or superseded by any part of the Public Unit 54 or any input from the Internet 3 or network 2, for example. A wireless connection can also provide the function of the secure control bus 48 a manner similar to that describing wireless connections above in FIGS. 2-6 describing buses 55 and 56.

The secure control bus 48 can also provide connection for the central controller to control a conventional firewall or for example access barrier or firewall 50c located on the periphery of the computer or microchip to control the connection of the computer PC1 and/or microchip 90 and/or 501 to the Internet 3 and/or intervening other network 2.

The secure control bus 48 can also be used by the master central controller 30, 31, 93, or 93' to control one or more secondary controllers 32 located on the bus 48 or anywhere in the computer PC1 and/or microchip 90 and/or 501, including in the Public Unit 54 that are used, for example, to control microprocessors or processing units or cores S (40 or 94) located in the Public Unit 54. The one or more secondary controllers 32 can be independent or integrated with the microprocessors or processing units or cores S (40 or 94) shown in FIGS. 9 and 11 above, for example; such integrated microprocessors can be a special purpose design or a common general purpose microprocessors like an Intel x86 microprocessor, for example.

FIG. 15 is an enlargement of the upper central portion of FIG. 1 showing a computer 1 and/or microchip 90 (and/or 501 and/or 1500, 1501, 1502, or 1503) and also shows a lock mechanism 51 in at least one hardware-based access barrier/firewall 50 for the transfer of data or code between units separated by access barrier/firewall 50, such as between the Private Unit 53 and the Public Unit 54.

FIG. 15 shows at least one random access memory RAM 66, which includes any volatile RAM, of which DRAM is a common example; volatile RAM is particularly useful because of its speed and ease of erase, such as by power interruption. The at least one RAM 66 component is located in the access barrier/firewall 50 and is connected to both units like the Public and Private Units 54 and 53 separated by the access barrier/firewall 50; the connection can be made, for example, by a bus, which can be unidirectional like 55 and 56 discussed in previous figures, or bidirectional like 55/56 shown in FIG. 15.

As shown, the access barrier/firewall lock mechanism 51 includes at least one switch 58 that is located between the RAM 66 component and the Public Unit 54 and is shown in the open position so that transmission of data and/or code is interrupted or blocked between RAM 66 and Public Unit 54. In addition, the lock mechanism 51 includes at least one switch 57 that is located between the RAM 66 component and the Private Unit 53 and is shown in the closed position so that the transmission of data and/or code is enabled between RAM 66 and Private Unit 53.

FIG. 15 shows the first state of what is an either/or condition of the access barrier/firewall lock mechanism 51. In the first state shown, data and/or code can be transmitted between the at least one RAM 66 component and the Private Unit 53 in either or both directions, but is blocked in both directions between the RAM 66 component and the Public Unit 54.

Finally, FIG. 15 shows the potential use anywhere in computers 1 and/or microchips 90 and/or 1500, 1501, 1502, or

1503 of a field programmable gate array or arrays (FPGA) 59 (or other means of active hardware configuration), as described under FIG. 1.

FIG. 16 is like FIG. 15 and shows the at least one access barrier/firewall lock mechanism 51, but shows the opposite condition of both switches 57 and 58 from that shown in FIG. 15. Switch 57 is shown in the open position so that the transmission of data and/or code is interrupted or blocked between RAM 66 and the Private Unit 53. Switch 58 is shown in the closed position so that the transmission of data and/or code is enabled between RAM 66 and the Public Unit 54.

FIG. 16 thus shows the second state of the either/or condition of the access barrier/firewall lock mechanism 51. In the second state shown, data and/or code can be transmitted between the RAM 66 component and the Public Unit 54 in either or both directions, but is blocked in either direction between the RAM 66 component and the Private Unit 53.

The access barrier/firewall lock mechanism 51 can include any number of the RAM 66 components, buses 55, 56, or 55/56, and switches 57 and 58 in any useful configuration in any of the access barriers/firewalls 50 shown in other figures of this application or in the applicant's previous related applications and patents that have been incorporated by reference. Any other components of the computer or microchip can also be incorporated temporarily or permanently in any lock mechanism 51 to provide additional useful functions. Any or all of the components of the lock mechanism can be controlled through the secure control bus 48.

In a general way, the lock mechanism 51 example shown in FIGS. 15 and 16 functions like a canal lock, which enable canal boats to avoid natural river rapids and instead be safely raised or lowered to different canal water levels by opening a first canal gate to allow a boat to enter at, for example, a lower water level and then shutting that first gate. Water is then allowed to enter the canal lock from the second gate, which holds back a higher level of water on the other side of the canal lock and which was shut when the boat first entered the canal lock. When a sufficient amount of water has entered the lock so that the water level is as high as that outside the second gate, the second gate can be opened to allow the boat to continue at the higher water level.

So in a manner like the canal lock allowing a boat to safely move between different water levels of a canal, the access barrier/firewall lock mechanism 51 allows data and/or code to move in a safely controlled fashion between different hardware-based security levels in a microchip or computer. The lock mechanism 51 allows data and/or code to be transmitted between different levels of microchip 90 (or computer 1 hardware) security, such as between a Public Unit 54 and a Private Unit 53, in a manner of transmission that can be controlled by the master controlling mechanism of the computer 1 and/or microchip 90 (and/or 501, and/or 1500, 1501, 1502, or 1503) using the secure control bus 48, for example.

The at least one lock mechanism 51 can provide other advantageous embodiments besides the either/or state described above, but the either/or state embodiment of the lock mechanism 51 described in FIGS. 15 and 16 does provide the definite benefit of allowing one and only one of either the Public Unit 54 or the Private Unit 53 to read and/or write to the RAM 66 component of the access barrier/firewall 50 at any given time, thus provide a high degree of secure control. No simultaneous access by both Units 53 and 54 would be possible with the locking mechanism 51 operating on the either/or state example shown.

The one or more access barrier/firewall lock mechanism 51 can include other computer or microchip components besides the one or more RAM 66 component shown that are useful to

fulfill the lock mechanism's general function, as well as to provide other security functions between units such as screening or testing data and/or code to be transmitted between units.

The RAM 66 component of the lock mechanism 51 shown in FIGS. 15 and 16 can be controlled using the secure control bus 48, including through the memory controller of the RAM 66 component.

Finally, FIG. 16 shows the potential use anywhere in computers 1 and/or microchips 90 and/or 1500, 1501, 1502, or 1503 of a field programmable gate array or arrays (FPGA) 59 (or other means of active hardware configuration), as described under FIG. 1.

FIG. 17A is similar to FIGS. 15 and 16 and shows one or more buffer zones 350 that functions like a DMZ (demilitarized zone) or moat between a Public Unit 54 and an access barrier/firewall 50; it is a physical barrier forming a boundary or zone without circuitry between Public and Private Units 54 and 53 so that any potential backdoor connections cannot be disguised in within a highly complex pattern of circuitry on a microchip (or motherboard of a computer, such as a smart phone, tablet computer, or personal computer); except for interruptions for authorized connections like the at least one secure control bus 48 (or buses 55, 56 or 55/56), an otherwise continuous boundary completely separating two units, such as the Units 54 and 53, provides the highest level of security. FIG. 17B shows a cross section of the FIG. 17A embodiment.

The at least one buffer zone 350 can be used, for example, with benefit in either or both of the floorplan or integrated circuit layout of a microchip 90 (and/or 501 and/or 1500, 1501, 1502, or 1503), but the buffer zone 350 provides a particularly significant security enhancement particularly when used in the physical design of a microchip 90 (and/or 501 and/or 1500, 1501, 1502, or 1503). One or more buffer zones 350 can be configured to provide a sufficient vacant space between the integrated circuits of the Public Unit 54 and the access barrier/firewall 50 (including the 50a, 50b, or 50c examples) to ensure that no "backdoor" connections exist between any portions of the Public Unit 54 and the Private Unit 53, or between any two portions of the microchip 90 (and/or 501 and/or 1500, 1501, 1502, or 1503) that are separated by an access barrier/firewall 50. The one or more buffer zones 350 can also be used in the same or similar manner in the motherboard of a computer.

Besides the absence of integrated circuitry, the one or more buffer zones 350 can usefully be configured in three dimensions so that, somewhat like a moat or an indentation, it can interrupt multiple layers of the microchip process used in making the microchip 90 (and/or 501 and/or 1500, 1501, 1502, or 1503), including 3D designs, so that there are no backdoor connections between the Public Unit 54 and the access barrier/firewall 50 (or any other units separated by an access barrier/firewall 50); a continuous boundary completely separating all microchip process layers between two units, such as the Units 54 and 53, provides the highest level of security.

The one or more buffer zones 350 can be of any number or configured in any size or shape or space necessary or useful to facilitate their function or that provides a security benefit. One or more of the buffer zones 350 can be usefully located at or near the same location as a part or all of one or more Faraday Cages 300 or Faraday Cage partitions 301, including for example fitting part or all of a boundary edge of a Faraday Cage 300 or partition 301 into a three dimensional moat-like or indented structure of the one or more buffer zones 350.

The one or more buffer zones **350** can also be configured to protect a part or all of one or more secure control buses **48**, such as in the Public Unit **54** as shown in the FIG. **17A** example embodiment.

The one or more buffer zones **350** can be particularly useful prior to microchip packaging (or computer assembly), so that it can be visually inspected, including by microscopic scanning or other device for manual or automated (including digital) comparison to an approved template, physical or digitized, including by xray or any other useful electromagnetic wavelength. The one or more buffer zones **350** can also be configured to include, for example, a non-conductive marker material in the form of a layer that outlines the boundary of the buffer zone, for example, to enhance the accuracy and speed of a scanning validation process to ensure compliance with an approved template and to mark the microchip for ease of alignment with the template.

The width of the buffer zone **350** can be configured to be any useful width, including to provide electromagnetic radiation buffering against interference or surveillance where a Faraday Cage **300** or partition **301** are not used; the width can be, for example, at least the size of process used in making the microchip **90** (and/or **501** and/or **1500**, **1501**, **1502**, or **1503**), such as current examples like 180, 130, 90, 65, 32, or 22 nanometer processes, or multiples of any of those processes, such as at least 360 nm, 480 nm, or 720 nm, for example.

The buffer zone **350** can also be positioned between, for example, the access barrier/firewall **50** and the Private Unit **53**, and it can be incorporated into the access barrier/firewall **50**.

More than one buffer zone **350** can be used between any two units in any configuration, as shown in the FIG. **17** example, which shows also one access barrier/firewall **50** with an integrated buffer zone **350** in its central portion.

The one or more buffer zones **350** can be configured to allow planned and/or authorized buses such as **55**, **56**, and/or **55/56**, and/or one or more secure control buses **48**, for example.

Finally, FIG. **17** shows the potential use anywhere in computers **1** and/or microchips **90** and/or **1500**, **1501**, **1502**, or **1503** of a field programmable gate array or arrays (FPGA) **59** or (other means of active hardware configuration), as described under FIG. **1**.

FIG. **18** is like FIG. **6**, but shows an example embodiment with the central controller (C) positioned in Private Unit **53¹** and a secondary controller (S) **32** in Private Unit **53²**, temporarily or permanently.

In accordance with the present disclosure, a method of protecting a computer is disclosed in FIG. **19**. The computer includes a master controlling device that is configured using hardware and firmware; at least two general purpose microprocessors; a protected portion of the computer; an unprotected portion of the computer; and an inner hardware-based access barrier or firewall that is located between the protected portion of the computer and the unprotected portion of the computer, the protected portion including at least the master controlling device and at least one of the microprocessors, and the unprotected portion including at least one of the microprocessors, the at least one microprocessor of the unprotected portion being separate from and located outside of the inner hardware-based access barrier or firewall. As shown in FIG. **19**, the method includes allowing a user of the computer to control the microprocessors (**150**); connecting the protected portion of the computer through a first connection to at least a private network of computers (**152**); connecting the unprotected portion of the computer through a second connection to a public network of computers including the

Internet (**154**); denying access by the hardware-based access barrier or firewall to the protected portion of the computer by the public network when the personal computer is connected to the public network (**156**); and permitting access by any other computer in the public network to the one or more of the processing units included in the unprotected portion of the computer for an operation with the any other computer in the public network when the personal computer is connected to the public network (**158**).

In accordance with the present disclosure, a method of protecting a computer disclosed in FIG. **20**. The computer includes a master controlling device that is configured using hardware and firmware; at least two general purpose microprocessors; a protected portion of the computer; an unprotected portion of the computer; and an inner hardware-based access barrier or firewall that is located between the protected portion of the computer and the unprotected portion of the computer, the protected portion including at least the master controlling device and at least one of the microprocessors, and the unprotected portion including at least one of the microprocessors, the at least one microprocessor of the unprotected portion being separate from and located outside of the inner hardware-based access barrier or firewall. As shown in FIG. **20**, the method includes connecting the protected portion of the computer through at least a first connection to at least a private network of computers (**160**); connecting the unprotected portion of the computer through a second connection to an public network of computers including the Internet (**162**); controlling the computer from the protected portion through the private network (**164**); and performing operations in the unprotected portion using the public network (**166**).

FIG. **21A** shows multiple firewalls **50**. FIG. **21A** shows a PC **1** or microchip **90** with a primary firewall **50** and additional interior firewalls **50¹**, **50²**, and **50³**, that are within primary firewall **50**. As shown, interior firewall **50³** is in the most protected position, since it is inside all the other firewalls, while the other interior firewalls **50²**, and **50¹** are progressively less protected, since, for example, interior firewall **50¹** is protected from the outside network only by the primary firewall **50**. As shown, progressively more protected positions can be created within the PC1 or microchip **90**. The interior firewalls can also be arranged in any other way within the primary firewall **50**. The interior firewalls can be used to separate user files from system files, for example, or to separate various hardware components from each other. In this manner, a number of compartments can be created within the PC1 or microchip **90** to more safely protect the software, hardware, and firmware of the PC1 or microchip **90**, just as ships have a number of separate watertight compartments to protect against flooding and avoid sinking. Any of the primary or interior (or other inner firewalls discussed below) can be hardware, software, or firmware, or a combination, and can coexist in layers, so that a firewall **50**, for example, may have a hardware firewall, a software firewall, and a firmware firewall, either as independent units or as integrated components. W³ in FIG. **21A** and subsequent Figures denotes the World Wide Web.

FIG. **21B** shows another embodiment of compartments created by inner firewalls within a PC1 or microchip **90**. Primary firewall **50** and interior firewall **50¹** are like FIG. **21A**, but interior firewalls **50²**, **50³**, and **50⁴** are shown perpendicular to firewalls **50** and **50¹** (just to illustrate in a simplified schematic way, which may be different in an actual embodiment). In this way, an upper row of compartments U¹ and U² can be used, for example, to bring from the network files which are first authenticated and then enter into the U¹

compartment, are decrypted, and undergo a security evaluation, such as by virus scan, before transfer to the most secure compartment U². Any operations could potentially occur in any compartment, depending on the level of security desired by the user (by over-ride) for example, but an advantageous default system would allow for files with the highest levels of authentication, encryption, and other security evaluations to be allowed into the most secure compartments.

Similarly, operating system files can also be authenticated and brought from the network side of the PC1 or microchip 90 into compartment O¹ for decryption and security evaluation or other use, and then finally transferred into the most secure compartment O².

Again, similarly, a row of compartments can be used for separating hardware, such as a master microprocessor 30 or 93 being located in compartment M¹ and a remote controller 31, for example, located in compartment M².

Also, additional inner firewalls 50²², 50³³, and 50⁴⁴ can be located outside the primary firewall 50, but within the network portion of the PC1 or microchip 90, to separate user files in compartment U from operating system files in compartment O from hardware such as a slave microprocessor in compartment S on the network side. In the example shown, an additional row is shown for hardware, including a hard drive in a compartment HD on the network side, a hard drive in compartment HD¹ on the PC1 or microchip 90 user's side, and flash memory (such as system bios 88) in compartment F². Each microprocessor 30, 40, 93, or 94 can have its own compartment in a manner like that shown in FIG. 23B, as can associated memory or any other hardware component.

FIG. 21C shows an inner firewall 50 embodiment similar to FIG. 21B, but FIG. 21C shows that any file or set of files, such as operating files O or user data files U or application files A, can have its own inner firewall 50^O or 50^U or 50^A. Similarly, any hardware component, such as hard drive HD, also can have its own inner firewall 50^{HD}. Additionally, more than one file or set of files or hardware components can be grouped together within an inner firewall, such as 50^S shown in FIG. 21C.

FIGS. 21D and 21E show operating system files O or application files A like those shown in FIG. 21C, but organized differently in discrete layers, each separate grouping of the operating or application files having a separate firewall 50 (and optionally with as well as a PC1 or PC90 firewall shown in earlier Figures), so that the firewall structure is like that of an onion. The operating system files O or application files A can have a parallel structure, with an innermost kernel operating system or application file located in the center, with additional features in other files in subsequent layers, from the simplest to the most complex and from the most secure and trusted to the least secure and trusted. Using this structure, as shown in FIG. 21D, an innermost operating system core O¹ may be firmware stored in a read-only memory (ROM), located in a microchip for quick access, so that a simplest version operating system with all core features can be protected absolutely from alteration and can be available almost immediately, without lengthy boot up procedures required by loading the operating system from a hard drive, for example. The core operating system O¹ can include a core of the system BIOS or of the operating system kernel, for example; it would be advantageous for this core to be capable of independent operation, not dependent on components in other levels to operate at the basic core level (similarly, other levels can advantageously be independent of higher levels).

A secondary operating system O² can be software located advantageously on flash or other microchip non-volatile memory such as magnetic (or less advantageously, a hard

drive or other mechanical storage media) and can consist of additional features that are more optional, such as those not always used in every session, or features that require updating, changing, or improving, such features coming from trusted sources located on a network, such as the Internet or the Web; additional portions of or upgrades to the system BIOS and the operating system kernel can be located in O², for example. A third level operating system O³ located, for example, on a hard drive, can consist of additional software features that are used only occasionally and are more optional, and can be loaded as needed by a user into DRAM or magnetic memory microchip for execution, for example. Operating systems O² and O³ can include, for example, the most recent upgrades from a known and trusted source, such as a commercial software vendor or open source software developer, that are downloaded from a network, including the Internet and the Web, or loaded from conventional memory media like CD or floppy diskette. All three levels of such operating systems O¹, O², and O³ together can constitute, for example, roughly the equivalent of a conventional PC operating system typical in the year 2000.

A fourth level operating system O⁴, for example, can consist of special use or single use operating system add-ons, especially software coming from untrusted or unauthenticated sources on a network, such as the Internet or the Web.

For example, the graphical interface of the operating system can be in 2D only at the O¹ level, in 3D at the O² level, rendering at the O³ level, and animation in the O⁴ level; additionally, a standard format can be maintained in the O¹ and O² levels, with user or vender customization at the O³ level.

As shown in FIG. 21E, application files such as A¹, A², A³, and A⁴ can be structured the same way as operating system files O in FIG. 21D and with the same layered approach to firewalls 50 as in FIG. 21D. Typical application software of the year 2000 can be restructured in this manner.

The kernel operating system files O¹ and O², as well as kernel application files A¹ and A² can be located in any personal computer PC1 or PC90, including at the level of an appliance including the simplest device, advantageously in ROM and in non-volatile read/write memory such as Flash (or magnetic such as MRAM, or ovonic memory) microchips, for example, as described in FIGS. 21D and 21E above. Inclusion of wireless connection capability is advantageous, as is the use of DWDM.

An advantage of the file and firewall structures shown in FIGS. 21D and 21E is that a system crash or file corruption should never occur at the simple and unalterable level O¹ or A¹ and any level above O¹ or A¹ can be recovered at a lower level, specifically the highest level at which there is a stable system or uncorrupted data. For example, a word processing application program can have the most basic functions of a typewriter (i.e. storing alphanumeric, punctuation, spacing, and paragraph structure data) stored on a ROM microchip in A¹ and related user files (i.e. such as a word document) on U². Insertion of a digital video file into a word document can be handled at the A³ level and insertion of a downloaded special effect at the A⁴ level. In this example, a crash caused by the insertion at the least secure and most complex A⁴ level would not disturb the word document located at the U² or U³ level. Rebooting and/or recovery can be automatic when detected by the operating system or at the option of the user.

Thus, FIGS. 21A-21E illustrate embodiments wherein a PC1 or microchip 90 includes a hierarchy of firewalls. In the context of the present invention, firewalls may be structured to allow varying degrees of access from the network side of PC1 or microchip 90. As discussed above, ROM may totally

25

deny access from the network side, effectively creating an innermost firewall. Hardware, software, firmware, or combinations thereof may be structured to deny or allow a predetermined maximum level of access from the network side, effectively creating outer firewalls. Similarly, intermediate firewalls effectively may be created.

Any one or more features or components of FIGS. 1-20 of this application can be usefully combined with one or more features or components of FIGS. 1-31 of the above '657 U.S. application or FIGS. 1-27 of the above '769 U.S. application. Each of the above '657 and '769 applications and their associated U.S. publications are expressly incorporated by reference in its entirety for completeness of disclosure of the applicant's combination of one or more features or components of either of those above two prior applications of this applicant with one or more features or components of this application. All such useful possible combinations are hereby expressly intended by this applicant.

Furthermore, any one or more features or components of FIGS. 1-20 of this application can be usefully combined with one or more features or components of the figures of the above '049 and '553 U.S. applications, as well as in the above '428, '250, '141, '449, '906, '275, '020, '854, '529, '756, and '233 U.S. patents. Each of the above '049 and '553 applications and their associated U.S. publications, as well as the above '428, '250, '141, '449, '906, '275, '020, '854, '529, '756, and '233 U.S. patents are expressly incorporated by reference in its entirety for completeness of disclosure of the applicant's combination of one or more features or components of either of those above two prior applications of this applicant with one or more features or components of this application. All such useful possible combinations are hereby expressly intended by this applicant.

In addition, one or more features or components of any one of FIGS. 1-20 or associated textual specification of this application can be usefully combined with one or more features or components of any one or more other of FIGS. 1-20 or associated textual specification of this application. And any such combination derived from the figures or associated text of this application can also be combined with any feature or component of the figures or associated text of any of the above incorporated by reference U.S. applications '657, '769, '049, and '553, as well as U.S. Pat. Nos. '428, '250, '141, '449, '906, '275, '020, '854, '529, '756, and '233.

The invention claimed is:

1. A computer or microchip comprising:

at least one network connection for connection to at least a public network of computers, said at least one network connection being located in at least one public unit of said computer or microchip,

at least one additional and separate network connection for connection to at least a separate, private network of computers, said at least one additional and separate network connection being located in at least one protected private unit of said computer or microchip, and

at least one inner hardware-based access barrier or inner hardware-based firewall that is located between and communicatively connects said at least one protected private unit of said computer or microchip and said at least one public unit of said computer or microchip wherein said private and public units and said two separate network connections are separated by said at least one inner hardware-based access barrier or inner hardware-based firewall; and

said at least one protected private unit of the computer or microchip includes at least a first microprocessor and a

26

system BIOS of the computer or microchip located in flash or other non-volatile memory;

said at least one public unit of the computer or microchip includes at least a second microprocessor, and said second microprocessor is separate from said at least one inner hardware-based access barrier or inner hardware-based firewall.

2. The computer or microchip of claim 1, wherein the at least one inner hardware-based access barrier or firewall comprises at least one bus with an on/off switch controlling communication input and output.

3. The computer or microchip of claim 1, wherein said at least one protected private unit of the computer or microchip includes a central controller of the computer or microchip, including a master controlling device or a master control unit.

4. The computer or microchip of claim 3, wherein said master controlling device comprises a microprocessor, core or processing unit configured for general purposes.

5. The computer or microchip of claim 1, wherein said at least one protected private unit of the computer or microchip is not configured to connect to the Internet.

6. The computer or microchip of claim 1, wherein the computer or microchip is included in one of a personal computer, a smartphone, a tablet computer, a server, a cloud server array, a blade, a cluster, a supercomputer, a supercomputer array, and a game machine.

7. The computer or microchip of claim 1, wherein the at least one public unit of the computer or microchip includes at least 2 or 4 or 8 or 16 or 32 or 64 or 128 or 256 or 512 or 1024 microprocessors or processing units or cores.

8. The computer or microchip of claim 1, wherein said at least one additional and separate network connection is at least one wired connection to said at least one separate, private network of computers.

9. The computer or microchip of claim 1, wherein said at least one additional and separate network connection is at least one wireless connection to said at least one separate, private network of computers.

10. The computer or microchip of claim 1, wherein the computer or microchip is surrounded by a Faraday Cage.

11. The computer or microchip of claim 1, wherein the at least one inner hardware-based access barrier or inner hardware-based firewall comprises a bus with an on/off switch controlling communication input and output.

12. The computer or microchip of claim 1, wherein the at least one public unit of the computer or microchip includes at least a second microprocessor configured to operate as a general purpose microprocessor.

13. The computer or microchip of claim 1, wherein the computer or microchip is configured to operate as a general purpose computer or microchip.

14. A computer or microchip configured to be securely controlled through a private network of computers, said computer or microchip comprising:

at least a secure private unit of said computer or microchip that is protected by at least one inner hardware-based access barrier or firewall;

an unprotected public unit of said computer or microchip, said unprotected public unit including at least one network connection for a public network of computers;

at least a separate private network connection for at least said private network of computers, at least said separate private network connection for said private network of computers being located in at least said secure private unit of said computer or microchip;

at least one microprocessor, core or processing unit configured for general purposes is located in said unprotected

27

tected public unit, wherein said at least one microprocessor, core or processing unit is separate from said at least one inner hardware-based access barrier or firewall;

at least a central controller of the computer or microchip, including a master controlling device or a master control unit and being located in said secure private unit;

a system BIOS of the computer or microchip located in flash or other non-volatile memory which is located in said secure private unit; and

a secure control bus configured to connect at least said master controlling device with at least said microprocessor, core or processing unit located in said unprotected public unit, said secure control bus being isolated from input from said network and input from components of said unprotected public unit; and

said master controlling device being configured for securely controlling at least one operation executed by at least one said microprocessor, core or processing unit in said unprotected public unit, said secure control being provided by said master controlling device in said secure private unit through said private network of computers to said additional and separate private network connection in said secure private unit and via said secure control bus.

15. The computer or microchip of claim 14, wherein the inner hardware-based access barrier or firewall comprises at least one bus with an on/off switch controlling communication input and output.

16. The computer or microchip of claim 15, wherein said secure control bus provides and ensures direct preemptive control by said master controlling device over said unprotected public unit.

17. The computer or microchip of claim 14, wherein said master controlling device comprises a microprocessor, core or processing unit configured for general purposes.

18. The computer or microchip of claim 17, wherein said master controlling device comprises a non-volatile memory.

19. The computer or microchip of claim 14, wherein said secure control bus is configured such that it cannot be affected, interfered with, altered, read from or written to, or superseded by any part of said unprotected public unit or by input from said network.

20. The computer or microchip of claim 19, wherein said one or more secondary controllers are used to control one or more of said at least one microprocessor, core or processing unit located in said unprotected public unit.

21. The computer or microchip of claim 20, wherein said one or more secondary controllers are integrated with one or more of said at least one microprocessor, core or processing unit located in said unprotected public unit.

22. The computer or microchip of claim 14, wherein said secure control bus is configured such that it can be used by said master controlling device to control one or more secondary controllers located on said secure control bus.

23. The computer or microchip of claim 22, wherein said one or more secondary controllers are located in the unprotected public unit.

24. The computer or microchip of claim 14, wherein said secure control bus is wired, wireless or a channel.

28

25. The computer or microchip of claim 14, wherein said secure control bus is configured to provide a connection to control at least a second firewall located on the periphery of said computer or microchip.

26. The computer or microchip of claim 14, wherein the inner hardware-based access barrier or inner hardware-based firewall comprises a bus with an on/off switch controlling communication input and output.

27. A computer or microchip configured to be securely controlled, said computer or microchip comprising:

at least one microprocessor, core or processing unit being configured for general purposes and having a connection for a network of computers;

at least a master controlling device for the computer or microchip; and

a system BIOS of the computer or microchip located in flash or other non-volatile memory which is located in a portion of the computer or microchip protected by an inner hardware-based access barrier or firewall; and

a secure control bus configured to connect at least said master controlling device with at least said at least one microprocessor, core or processing unit, and said secure control bus being isolated from input from said network and input from components of said computer or microchip other than said master controlling device; and

said master controlling device being configured for securely controlling at least one operation executed by at least one said microprocessor, core or processing unit, said secure control being provided by said master controlling device via said secure control bus.

28. The computer or microchip of claim 27, wherein the inner hardware-based access barrier or firewall comprises a bus with an on/off switch controlling communication input and output.

29. The computer or microchip of claim 27, wherein said master controlling device comprises a microprocessor, core or processing unit configured for general purposes.

30. The computer or microchip of claim 27, wherein said master controlling device comprises a non-volatile memory.

31. The computer or microchip of claim 27, wherein said secure control bus provides and ensures direct preemptive control by said master controlling device over said at least one microprocessor, core or processing unit.

32. The computer or microchip of claim 27, wherein said secure control bus is configured such that it cannot be affected, interfered with, altered, read from or written to, or superseded by any part of said unprotected public unit or by input from said network.

33. The computer or microchip of claim 27, wherein said secure control bus is configured such that it can be used by said master controlling device to control one or more secondary controllers located on said secure control bus.

34. The computer or microchip of claim 27, wherein said secure control bus is wired, wireless or a channel.

35. The computer or microchip of claim 27, wherein said secure control bus provides a connection to control a firewall located on the periphery of said computer or microchip.

* * * * *