



US008670246B2

(12) **United States Patent**  
**Ellis**

(10) **Patent No.:** **US 8,670,246 B2**

(45) **Date of Patent:** **Mar. 11, 2014**

(54) **COMPUTERS INCLUDING AN UNDICED SEMICONDUCTOR WAFER WITH FARADAY CAGES AND INTERNAL FLEXIBILITY SIPIES**

(76) Inventor: **Frampton E. Ellis**, Jasper, FL (US)

(\* ) Notice: Subject to any disclaimer, the term of this patent is extended or adjusted under 35 U.S.C. 154(b) by 0 days.

(21) Appl. No.: **13/404,888**

(22) Filed: **Feb. 24, 2012**

(65) **Prior Publication Data**

US 2012/0155002 A1 Jun. 21, 2012

**Related U.S. Application Data**

(63) Continuation of application No. 12/292,769, filed on Nov. 25, 2008, now Pat. No. 8,125,796, which is a continuation-in-part of application No. 12/292,553, filed on Nov. 20, 2008, now Pat. No. 8,164,170.

(60) Provisional application No. 60/996,530, filed on Nov. 21, 2007, provisional application No. 60/996,553, filed on Nov. 26, 2007.

(51) **Int. Cl.**  
**G06F 1/20** (2006.01)  
**H05K 9/00** (2006.01)

(52) **U.S. Cl.**  
USPC . **361/818**; 361/816; 361/679.01; 361/679.02; 361/679.03; 361/679.26; 257/48; 257/316; 257/682; 257/685; 257/687; 438/130; 438/132; 438/456

(58) **Field of Classification Search**  
USPC ..... 361/679.01-679.26, 715-727, 732, 361/756, 816, 818, 831; 257/E21.521, 257/E21.524, 48, 620, 621, 682, 685, 686, 257/698, 203, 303, 213, 786, 768-770, 773, 257/774, 659, E23.114; 438/106-118, 438/130-132, 238, 455, 456; 174/350, 387, 174/50, 50.54, 525; 726/11, 22, 30

See application file for complete search history.

(56) **References Cited**

U.S. PATENT DOCUMENTS

193,914 A 8/1877 Berry  
280,791 A 7/1883 Brooks

(Continued)

FOREIGN PATENT DOCUMENTS

AU 200963 5/1958  
CA 1138194 12/1982

(Continued)

OTHER PUBLICATIONS

International Search Report for PCT/US08/13098, dated Feb. 4, 2006.

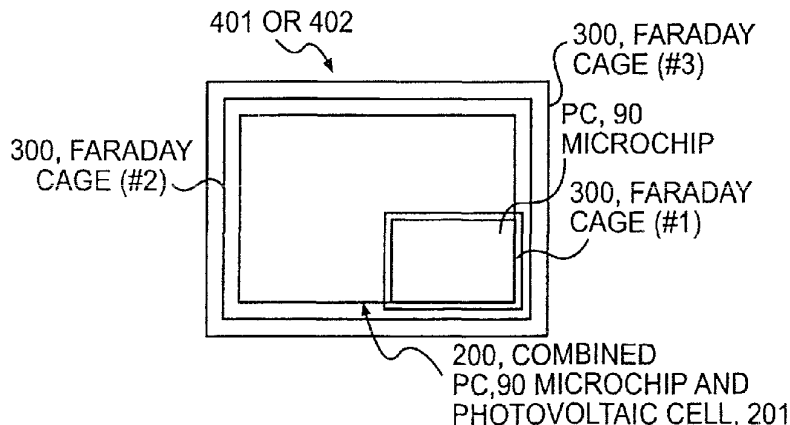
(Continued)

*Primary Examiner* — Michail V Datskovskiy  
(74) *Attorney, Agent, or Firm* — Menselsohn, Drucker & Drucker, P.C.

(57) **ABSTRACT**

A computer including an undiced semiconductor wafer having a multitude of microchips. The computer also including an outer chamber and at least one inner chamber inside the outer chamber. The outer chamber and the inner chamber being separated at least in part by an internal sipe, and at least a portion of a surface of the outer chamber forming at least a portion of a surface of the internal sipe. The internal sipe has opposing surfaces that are separate from each other and therefore can move relative to each other, and at least a portion of the opposing surfaces are in contact with each other in a unloaded condition. The outer chamber including a Faraday Cage. The multitude of microchips on the wafer are configured to allow the microchip to function independently and including independent communication capabilities.

**45 Claims, 31 Drawing Sheets**



(56)

## References Cited

## U.S. PATENT DOCUMENTS

|             |         |                  |             |         |                     |
|-------------|---------|------------------|-------------|---------|---------------------|
| 288,127 A   | 11/1883 | Shepard          | 4,064,565 A | 12/1977 | Griffiths           |
| 500,385 A   | 6/1893  | Hall             | 4,067,063 A | 1/1978  | Ettinger            |
| 532,429 A   | 1/1895  | Rogers           | 4,068,395 A | 1/1978  | Senter              |
| 584,373 A   | 6/1897  | Kuhn             | 4,083,125 A | 4/1978  | Benseler et al.     |
| 1,283,335 A | 10/1918 | Shillcock        | 4,096,649 A | 6/1978  | Saurwein            |
| 1,289,106 A | 12/1918 | Bullock          | 4,098,011 A | 7/1978  | Bowerman et al.     |
| D55,115 S   | 5/1920  | Barney           | 4,128,950 A | 12/1978 | Bowerman et al.     |
| 1,458,446 A | 6/1923  | Schaeffer        | 4,128,951 A | 12/1978 | Transill            |
| 1,622,860 A | 3/1927  | Cutler           | 4,141,158 A | 2/1979  | Benseler et al.     |
| 1,639,381 A | 8/1927  | Manelas          | 4,145,785 A | 3/1979  | Lacey               |
| 1,701,260 A | 2/1929  | Fischer          | 4,149,324 A | 4/1979  | Lesser et al.       |
| 1,735,986 A | 11/1929 | Wray             | 4,161,828 A | 7/1979  | Benseler et al.     |
| 1,853,034 A | 4/1932  | Bradley          | 4,161,829 A | 7/1979  | Wayser              |
| 2,004,906 A | 6/1935  | Simister         | 4,170,078 A | 10/1979 | Moss                |
| 2,120,987 A | 6/1938  | Murray           | 4,172,495 A | 10/1979 | Zebuhr et al.       |
| 2,147,197 A | 2/1939  | Glidden          | 4,183,156 A | 1/1980  | Rudy                |
| 2,155,166 A | 4/1939  | Kraft            | 4,194,310 A | 3/1980  | Bowerman            |
| 2,162,912 A | 6/1939  | Craver           | D256,180 S  | 8/1980  | Turner              |
| 2,170,652 A | 8/1939  | Brennan          | D256,400 S  | 8/1980  | Famolare, Jr.       |
| 2,179,942 A | 11/1939 | Lyne             | 4,217,705 A | 8/1980  | Donzis              |
| D119,894 S  | 4/1940  | Sherman          | 4,219,945 A | 9/1980  | Rudy                |
| 2,201,300 A | 5/1940  | Prue             | 4,223,457 A | 9/1980  | Borgeas             |
| 2,206,860 A | 7/1940  | Sperry           | 4,227,320 A | 10/1980 | Borgeas             |
| D122,131 S  | 8/1940  | Sannar           | 4,235,026 A | 11/1980 | Plagenhoef          |
| D128,817 S  | 8/1941  | Esterson         | 4,237,627 A | 12/1980 | Landay et al.       |
| 2,251,468 A | 8/1941  | Smith            | 4,240,214 A | 12/1980 | Sigle et al.        |
| 2,328,242 A | 8/1943  | Witherill        | 4,241,523 A | 12/1980 | Daswick             |
| 2,345,831 A | 4/1944  | Pierson          | 4,245,306 A | 1/1981  | Besemer et al.      |
| 2,433,329 A | 12/1947 | Adler et al.     | 4,245,406 A | 1/1981  | Landay              |
| 2,434,770 A | 1/1948  | Lutey            | 4,250,638 A | 2/1981  | Linnemann           |
| 2,470,200 A | 5/1949  | Wallach          | 4,258,480 A | 3/1981  | Famolare, Jr.       |
| 2,546,827 A | 3/1951  | Lavinthal        | 4,259,792 A | 4/1981  | Halberstadt         |
| 2,627,676 A | 2/1953  | Hack             | 4,262,433 A | 4/1981  | Hagg et al.         |
| 2,718,715 A | 9/1955  | Spilman          | 4,263,728 A | 4/1981  | Frecentese          |
| 2,762,134 A | 9/1956  | Town             | 4,266,349 A | 5/1981  | Schmohl             |
| 2,814,133 A | 11/1957 | Herbst           | 4,268,980 A | 5/1981  | Gudas               |
| 3,005,272 A | 10/1961 | Shelare et al.   | 4,271,606 A | 6/1981  | Rudy                |
| 3,087,261 A | 4/1963  | Russell          | 4,272,858 A | 6/1981  | Hlustik             |
| 3,100,354 A | 8/1963  | Lombard et al.   | 4,274,211 A | 6/1981  | Funck               |
| 3,110,971 A | 11/1963 | Chang            | 4,276,594 A | 6/1981  | Morley              |
| 3,170,250 A | 2/1965  | Scholl           | 4,278,837 A | 7/1981  | Best                |
| 3,171,133 A | 3/1965  | Steffen          | 4,297,797 A | 11/1981 | Meyers              |
| 3,186,004 A | 6/1965  | Carlini          | 4,302,892 A | 12/1981 | Adamik              |
| 3,204,678 A | 9/1965  | Worcester        | 4,305,212 A | 12/1981 | Coomer              |
| 3,242,500 A | 3/1966  | Derr             | 4,308,671 A | 1/1982  | Bretschneider       |
| 3,248,738 A | 5/1966  | Morgan           | 4,309,832 A | 1/1982  | Hunt                |
| 3,253,355 A | 5/1966  | Menkin           | 4,316,332 A | 2/1982  | Giese et al.        |
| 3,305,947 A | 2/1967  | Kal soy          | 4,316,335 A | 2/1982  | Giese et al.        |
| 3,308,560 A | 3/1967  | Jones            | 4,319,412 A | 3/1982  | Muller et al.       |
| 3,407,406 A | 10/1968 | Werner et al.    | D264,017 S  | 4/1982  | Turner              |
| 3,416,174 A | 12/1968 | Novitske         | 4,322,895 A | 4/1982  | Hockerson           |
| 3,469,576 A | 9/1969  | Everts et al.    | D265,019 S  | 6/1982  | Vernonet            |
| 3,512,274 A | 5/1970  | McGrath          | 4,335,529 A | 6/1982  | Badalamenti         |
| 3,535,799 A | 10/1970 | Onituska         | 4,340,626 A | 7/1982  | Rudy                |
| 3,539,876 A | 11/1970 | Sitler et al.    | 4,342,161 A | 8/1982  | Schmohl             |
| 3,600,714 A | 8/1971  | Cade et al.      | 4,345,338 A | 8/1982  | Frieder, Jr. et al. |
| 3,806,950 A | 4/1974  | Spencer-Foote    | 4,348,821 A | 9/1982  | Daswick             |
| 3,806,974 A | 4/1974  | DiPaolo          | 4,354,284 A | 10/1982 | Gooding             |
| 3,824,716 A | 7/1974  | DiPaolo          | 4,354,319 A | 10/1982 | Block et al.        |
| 3,834,046 A | 9/1974  | Fowler           | 4,361,971 A | 12/1982 | Bowerman            |
| 3,835,530 A | 9/1974  | Kilby            | 4,366,634 A | 1/1983  | Giese et al.        |
| 3,849,801 A | 11/1974 | Holt et al.      | 4,370,817 A | 2/1983  | Ratanangsu          |
| 3,863,366 A | 2/1975  | Auberry et al.   | 4,372,059 A | 2/1983  | Ambrose             |
| 3,872,511 A | 3/1975  | Nichols          | 4,375,108 A | 3/1983  | Gooding             |
| 3,958,291 A | 5/1976  | Spier            | 4,398,357 A | 8/1983  | Batra               |
| 3,964,181 A | 6/1976  | Holcombe, Jr.    | 4,399,620 A | 8/1983  | Funck               |
| 3,995,320 A | 12/1976 | Zafuto           | D272,294 S  | 1/1984  | Watanabe            |
| 3,997,984 A | 12/1976 | Hayward          | 4,432,099 A | 2/1984  | Grick et al.        |
| 4,003,145 A | 1/1977  | Liebscher et al. | 4,449,306 A | 5/1984  | Cavanagh            |
| 4,023,213 A | 5/1977  | Rovani           | 4,451,994 A | 6/1984  | Fowler              |
| 4,030,213 A | 6/1977  | Daswick          | 4,454,662 A | 6/1984  | Stubblefield        |
| 4,035,846 A | 7/1977  | Jencks           | 4,455,765 A | 6/1984  | Sjösward            |
| 4,043,058 A | 8/1977  | Hollister et al. | 4,455,767 A | 6/1984  | Bergmans            |
| 4,059,910 A | 11/1977 | Bryden           | 4,467,400 A | 8/1984  | Stopper             |
| 4,060,855 A | 12/1977 | Rapleyea         | 4,468,870 A | 9/1984  | Sternberg           |
|             |         |                  | 4,484,364 A | 11/1984 | Mitchell et al.     |
|             |         |                  | 4,484,397 A | 11/1984 | Curley, Jr.         |
|             |         |                  | 4,489,397 A | 12/1984 | Lee                 |
|             |         |                  | 4,494,321 A | 1/1985  | Lawlor              |

(56)

## References Cited

## U.S. PATENT DOCUMENTS

|             |         |                 |             |         |                   |
|-------------|---------|-----------------|-------------|---------|-------------------|
| 4,505,055 A | 3/1985  | Bergmans        | 4,897,936 A | 2/1990  | Fuerst            |
| 4,506,462 A | 3/1985  | Cavanagh        | 4,906,502 A | 3/1990  | Rudy              |
| 4,521,979 A | 6/1985  | Blaser          | 4,907,228 A | 3/1990  | Bruckert et al.   |
| 4,527,345 A | 7/1985  | Lopez           | 4,918,596 A | 4/1990  | Nakano            |
| D280,568 S  | 9/1985  | Stubblefield    | 4,922,631 A | 5/1990  | Anderie           |
| 4,538,301 A | 9/1985  | Sawatzki et al. | 4,934,070 A | 6/1990  | Mauger            |
| 4,542,598 A | 9/1985  | Misevich et al. | 4,934,073 A | 6/1990  | Robinson          |
| 4,546,559 A | 10/1985 | Dassler         | D310,131 S  | 8/1990  | Hase              |
| 4,547,979 A | 10/1985 | Harada          | D310,132 S  | 8/1990  | Hase              |
| 4,557,059 A | 12/1985 | Misevich et al. | 4,947,560 A | 8/1990  | Fuerst et al.     |
| 4,559,723 A | 12/1985 | Hamy et al.     | 4,949,476 A | 8/1990  | Anderie           |
| 4,559,724 A | 12/1985 | Norton          | D310,906 S  | 10/1990 | Hase              |
| 4,561,195 A | 12/1985 | Onoda et al.    | 4,969,092 A | 11/1990 | Shorter           |
| 4,570,362 A | 2/1986  | Vermonet        | 4,972,527 A | 11/1990 | Wallace           |
| 4,577,417 A | 3/1986  | Cole            | 4,979,794 A | 12/1990 | Evans             |
| 4,578,882 A | 4/1986  | Talarico, II    | 4,982,737 A | 1/1991  | Guttman           |
| 4,580,359 A | 4/1986  | Kurrash et al.  | 4,989,349 A | 2/1991  | Ellis, III        |
| 4,624,061 A | 11/1986 | Wezel et al.    | D315,634 S  | 3/1991  | Wahoske et al.    |
| 4,624,062 A | 11/1986 | Autry et al.    | 5,010,662 A | 4/1991  | Dabuzhsky et al.  |
| 4,638,577 A | 1/1987  | Riggs           | 5,012,597 A | 5/1991  | Thomasson         |
| 4,641,438 A | 2/1987  | Laird et al.    | 5,014,365 A | 5/1991  | Schulz            |
| 4,642,917 A | 2/1987  | Ungar           | 5,014,449 A | 5/1991  | Richard et al.    |
| 4,651,445 A | 3/1987  | Hannibal        | 5,024,007 A | 6/1991  | DuFour            |
| D289,341 S  | 4/1987  | Turner          | 5,025,369 A | 6/1991  | Schwartz          |
| 4,654,983 A | 4/1987  | Graham          | 5,025,573 A | 6/1991  | Giese et al.      |
| 4,658,515 A | 4/1987  | Oatman          | 5,027,864 A | 7/1991  | Conti et al.      |
| 4,667,423 A | 5/1987  | Autry           | 5,031,089 A | 7/1991  | Liu et al.        |
| 4,670,995 A | 6/1987  | Huang           | 5,048,203 A | 9/1991  | Kling             |
| 4,676,010 A | 6/1987  | Cheskin         | D320,302 S  | 10/1991 | Kiyosawa          |
| 4,694,591 A | 9/1987  | Banich et al.   | 2,052,130 A | 10/1991 | Barry et al.      |
| 4,697,361 A | 10/1987 | Ganter et al.   | 5,052,130 A | 10/1991 | Barry             |
| 4,703,436 A | 10/1987 | Varshney        | 5,068,780 A | 11/1991 | Bruckert et al.   |
| D293,275 S  | 12/1987 | Bua             | 5,077,916 A | 1/1992  | Beneteau          |
| 4,715,133 A | 12/1987 | Hartjes et al.  | 5,079,856 A | 1/1992  | Treulsen          |
| 4,724,622 A | 2/1988  | Mills           | 5,083,320 A | 1/1992  | Halstead          |
| D294,425 S  | 3/1988  | Le              | 5,092,060 A | 3/1992  | Frachey et al.    |
| 4,727,660 A | 3/1988  | Bernhard        | 5,095,545 A | 3/1992  | Lane              |
| 4,730,402 A | 3/1988  | Norton et al.   | 5,103,393 A | 4/1992  | Harris et al.     |
| 4,731,939 A | 3/1988  | Parracho et al. | 5,109,329 A | 4/1992  | Strelloff         |
| 4,736,317 A | 4/1988  | Hu et al.       | 5,109,512 A | 4/1992  | Bahr et al.       |
| 4,747,139 A | 5/1988  | Taaffe          | D327,164 S  | 6/1992  | Hatfield          |
| 4,747,220 A | 5/1988  | Autry et al.    | D327,165 S  | 6/1992  | Hatfield          |
| D296,149 S  | 6/1988  | Diaz            | 5,131,173 A | 7/1992  | Anderie           |
| D296,152 S  | 6/1988  | Selbiger        | 5,136,708 A | 8/1992  | LaPourtre et al.  |
| 4,748,753 A | 6/1988  | Ju              | D328,968 S  | 9/1992  | Tinker            |
| 4,754,561 A | 7/1988  | DuFour          | D329,528 S  | 9/1992  | Hatfield          |
| 4,756,098 A | 7/1988  | Boggia          | D329,739 S  | 9/1992  | Hatfield          |
| 4,757,620 A | 7/1988  | Tiitola         | 5,153,945 A | 10/1992 | Kobayashi et al.  |
| 4,759,136 A | 7/1988  | Stewart et al.  | 5,155,808 A | 10/1992 | Shimizu           |
| 4,768,295 A | 9/1988  | Ito             | D330,972 S  | 11/1992 | Hatfield et al.   |
| 4,769,926 A | 9/1988  | Meyers          | D332,344 S  | 1/1993  | Hatfield et al.   |
| 4,777,738 A | 10/1988 | Giese           | D332,692 S  | 1/1993  | Hatfield et al.   |
| D298,684 S  | 11/1988 | Pitchford       | 5,175,889 A | 1/1993  | Infusino          |
| 4,783,910 A | 11/1988 | Boys            | 5,191,727 A | 3/1993  | Barry et al.      |
| 4,784,462 A | 11/1988 | Priaroggia      | 5,195,031 A | 3/1993  | Ordish            |
| 4,785,557 A | 11/1988 | Kelley et al.   | 5,204,998 A | 4/1993  | Liu               |
| 4,802,289 A | 2/1989  | Guldager        | 5,212,780 A | 5/1993  | Padgaonkar et al. |
| 4,817,304 A | 4/1989  | Parker et al.   | 5,214,657 A | 5/1993  | Farnworth et al.  |
| 4,827,508 A | 5/1989  | Shear           | 5,224,280 A | 7/1993  | Preman et al.     |
| 4,827,631 A | 5/1989  | Thornton        | 5,224,810 A | 7/1993  | Pitkin            |
| 4,833,795 A | 5/1989  | Diaz            | 5,237,507 A | 8/1993  | Chasek            |
| 4,837,949 A | 6/1989  | Dufour          | 5,237,758 A | 8/1993  | Zachman           |
| D302,900 S  | 8/1989  | Kolman et al.   | 5,247,742 A | 9/1993  | Kilgore et al.    |
| 4,853,980 A | 8/1989  | Zarotti         | 5,259,070 A | 11/1993 | De Roza           |
| 4,854,057 A | 8/1989  | Misevich et al. | 5,259,071 A | 11/1993 | Scott et al.      |
| 4,855,903 A | 8/1989  | Carleton et al. | 5,260,943 A | 11/1993 | Comroe et al.     |
| 4,858,340 A | 8/1989  | Pasternak       | 5,263,203 A | 11/1993 | Kraemer et al.    |
| 4,864,737 A | 9/1989  | Marrello        | 5,282,272 A | 1/1994  | Guy et al.        |
| 4,864,738 A | 9/1989  | Horovitz        | 5,283,819 A | 2/1994  | Glick et al.      |
| 4,866,861 A | 9/1989  | Noone           | D345,249 S  | 3/1994  | Sell, Jr.         |
| 4,876,807 A | 10/1989 | Tiitola et al.  | 5,291,494 A | 3/1994  | Bruckert et al.   |
| 4,890,398 A | 1/1990  | Thomasson       | 5,291,502 A | 3/1994  | Pezeshki et al.   |
| 4,893,174 A | 1/1990  | Yamada et al.   | 5,291,505 A | 3/1994  | Nielsen           |
| 4,894,932 A | 1/1990  | Harada          | D347,105 S  | 5/1994  | Johnson           |
| 4,894,933 A | 1/1990  | Tonkel et al.   | 5,317,819 A | 6/1994  | Ellis, III        |
|             |         |                 | 5,341,477 A | 8/1994  | Pitkin et al.     |
|             |         |                 | 5,343,639 A | 9/1994  | Kilgore et al.    |
|             |         |                 | 5,349,682 A | 9/1994  | Rosenberry        |
|             |         |                 | 5,353,459 A | 10/1994 | Potter            |

(56)

## References Cited

## U.S. PATENT DOCUMENTS

|             |         |                     |              |         |                     |
|-------------|---------|---------------------|--------------|---------|---------------------|
| 5,353,523 A | 10/1994 | Kilgore             | 5,813,142 A  | 9/1998  | Demon               |
| 5,357,404 A | 10/1994 | Bright et al.       | 5,815,665 A  | 9/1998  | Teper et al.        |
| 5,357,632 A | 10/1994 | Pian et al.         | 5,815,793 A  | 9/1998  | Ferguson            |
| 5,361,362 A | 11/1994 | Benkeser et al.     | 5,823,852 A  | 10/1998 | Chu                 |
| 5,361,410 A | 11/1994 | Sigl                | 5,826,014 A  | 10/1998 | Coley et al.        |
| 5,369,896 A | 12/1994 | Frachey et al.      | 5,826,029 A  | 10/1998 | Gore, Jr. et al.    |
| 5,381,534 A | 1/1995  | Shi                 | 5,828,833 A  | 10/1998 | Belville et al.     |
| 5,388,211 A | 2/1995  | Hornbuckle          | 5,835,726 A  | 11/1998 | Shwed et al.        |
| 5,392,400 A | 2/1995  | Berkowitz et al.    | 5,838,436 A  | 11/1998 | Hotaling et al.     |
| 5,410,651 A | 4/1995  | Sekizawa et al.     | 5,838,542 A  | 11/1998 | Nelson et al.       |
| 5,426,741 A | 6/1995  | Butts, Jr. et al.   | 5,843,799 A  | 12/1998 | Hsu et al.          |
| 5,428,783 A | 6/1995  | Lake                | 5,844,594 A  | 12/1998 | Ferguson            |
| 5,434,998 A | 7/1995  | Akai et al.         | 5,845,074 A  | 12/1998 | Kobata              |
| 5,446,843 A | 8/1995  | Fucito et al.       | 5,846,063 A  | 12/1998 | Lakic               |
| 5,457,797 A | 10/1995 | Butterworth et al.  | 5,850,449 A  | 12/1998 | McManis             |
| 5,475,606 A | 12/1995 | Muyshondt et al.    | 5,861,817 A  | 1/1999  | Palmer et al.       |
| 5,497,465 A | 3/1996  | Chin et al.         | 5,862,357 A  | 1/1999  | Hagersten et al.    |
| 5,515,511 A | 5/1996  | Nguyen et al.       | 5,864,738 A  | 1/1999  | Kessler et al.      |
| 5,522,070 A | 5/1996  | Surnimoto           | 5,870,721 A  | 2/1999  | Norris              |
| D372,114 S  | 7/1996  | Turner et al.       | 5,872,987 A  | 2/1999  | Wade et al.         |
| 5,535,408 A | 7/1996  | Hillis              | 5,881,284 A  | 3/1999  | Kubo                |
| 5,539,934 A | 7/1996  | Ponder              | 5,889,989 A  | 3/1999  | Robertazzi et al.   |
| 5,543,194 A | 8/1996  | Rudy                | 5,896,499 A  | 4/1999  | McKelvey            |
| 5,544,429 A | 8/1996  | Ellis, III          | D409,362 S   | 5/1999  | Turner et al.       |
| 5,546,594 A | 8/1996  | Wazumi              | D409,826 S   | 5/1999  | Turner et al.       |
| 5,550,984 A | 8/1996  | Gelb                | D410,138 S   | 5/1999  | Turner et al.       |
| 5,555,584 A | 9/1996  | Moore, III et al.   | 5,905,429 A  | 5/1999  | Hornstein et al.    |
| 5,568,375 A | 10/1996 | Rausch              | 5,909,052 A  | 6/1999  | Ohta et al.         |
| 5,570,270 A | 10/1996 | Naedel et al.       | 5,909,681 A  | 6/1999  | Passera et al.      |
| 5,572,643 A | 11/1996 | Judson              | 5,909,948 A  | 6/1999  | Ellis, III          |
| 5,572,805 A | 11/1996 | Giese et al.        | 5,913,412 A  | 6/1999  | Huber et al.        |
| 5,576,554 A | 11/1996 | Hsu                 | 5,917,629 A  | 6/1999  | Hortensius et al.   |
| 5,586,121 A | 12/1996 | Moura et al.        | 5,919,247 A  | 7/1999  | Van Hoff et al.     |
| 5,587,928 A | 12/1996 | Jones et al.        | 5,930,511 A  | 7/1999  | Hinsley             |
| 5,588,003 A | 12/1996 | Ohba et al.         | 5,930,918 A  | 8/1999  | Skaja et al.        |
| 5,590,284 A | 12/1996 | Crosetto            | 5,933,984 A  | 8/1999  | Carlson et al.      |
| 5,592,376 A | 1/1997  | Hodroff             | 5,943,421 A  | 8/1999  | Grabon              |
| 5,592,632 A | 1/1997  | Leung et al.        | 5,956,777 A  | 9/1999  | Popovich            |
| 5,594,491 A | 1/1997  | Hodge et al.        | 5,964,832 A  | 10/1999 | Kisor               |
| 5,600,597 A | 2/1997  | Kean et al.         | 5,976,451 A  | 11/1999 | Healy et al.        |
| 5,604,882 A | 2/1997  | Hoover et al.       | 5,978,829 A  | 11/1999 | Chung et al.        |
| 5,606,615 A | 2/1997  | Lapointe et al.     | 5,979,078 A  | 11/1999 | McLaughlin          |
| 5,608,448 A | 3/1997  | Smoral et al.       | 5,987,781 A  | 11/1999 | Pavesi et al.       |
| 5,615,127 A | 3/1997  | Beatty et al.       | 6,003,133 A  | 12/1999 | Moughanni et al.    |
| 5,627,879 A | 5/1997  | Russell et al.      | 6,023,857 A  | 2/2000  | Vizy et al.         |
| 5,666,484 A | 9/1997  | Orimo et al.        | 6,052,555 A  | 4/2000  | Ferguson            |
| 5,675,844 A | 10/1997 | Guyton et al.       | 6,065,118 A  | 5/2000  | Bull et al.         |
| 5,678,028 A | 10/1997 | Bershteyn et al.    | 6,067,082 A  | 5/2000  | Enmei               |
| 5,678,327 A | 10/1997 | Halberstadt         | 6,073,209 A  | 6/2000  | Bergsten            |
| 5,680,461 A | 10/1997 | McManis             | 6,073,271 A  | 6/2000  | Alexander et al.    |
| 5,680,548 A | 10/1997 | Trugman             | 6,078,733 A  | 6/2000  | Osborne             |
| 5,696,902 A | 12/1997 | Leclercq et al.     | 6,093,933 A  | 7/2000  | Farnworth et al.    |
| 5,699,528 A | 12/1997 | Hogan               | 6,098,091 A  | 8/2000  | Kisor               |
| 5,701,507 A | 12/1997 | Bonneau, Jr. et al. | 6,098,209 A  | 8/2000  | Bainbridge et al.   |
| D388,594 S  | 1/1998  | Turner et al.       | 6,112,225 A  | 8/2000  | Kraft et al.        |
| 5,710,884 A | 1/1998  | Dedrick             | 6,112,243 A  | 8/2000  | Downs et al.        |
| 5,734,913 A | 3/1998  | Iwamura et al.      | 6,115,698 A  | 9/2000  | Tuck et al.         |
| 5,748,489 A | 5/1998  | Beatty et al.       | 6,115,941 A  | 9/2000  | Ellis, III          |
| 5,751,881 A | 5/1998  | Konda et al.        | 6,115,945 A  | 9/2000  | Ellis, III          |
| 5,752,067 A | 5/1998  | Wilkinson et al.    | 6,163,982 A  | 12/2000 | Ellis, III          |
| 5,754,766 A | 5/1998  | Shaw et al.         | 6,167,428 A  | 12/2000 | Ellis               |
| 5,758,077 A | 5/1998  | Danahy et al.       | 6,178,560 B1 | 1/2001  | Halstead et al.     |
| 5,758,345 A | 5/1998  | Wang                | 6,208,634 B1 | 3/2001  | Boulos et al.       |
| 5,761,507 A | 6/1998  | Govett              | 6,219,627 B1 | 4/2001  | Bonneau et al.      |
| 5,764,889 A | 6/1998  | Ault et al.         | 6,226,801 B1 | 5/2001  | Alexander et al.    |
| 5,774,337 A | 6/1998  | Lee et al.          | D444,293 S   | 7/2001  | Turner et al.       |
| 5,774,668 A | 6/1998  | Choquier et al.     | 6,253,466 B1 | 7/2001  | Harmon-Weiss et al. |
| 5,774,721 A | 6/1998  | Robinson            | 6,268,788 B1 | 7/2001  | Gray                |
| 5,784,551 A | 7/1998  | De Leva et al.      | 6,287,949 B1 | 9/2001  | Mori et al.         |
| 5,784,628 A | 7/1998  | Reneris             | 6,308,439 B1 | 10/2001 | Ellis               |
| 5,790,431 A | 8/1998  | Ahrens, Jr. et al.  | 6,308,813 B1 | 10/2001 | Carlson             |
| 5,793,968 A | 8/1998  | Gregerson et al.    | D450,916 S   | 11/2001 | Turner et al.       |
| 5,794,059 A | 8/1998  | Barker et al.       | 6,314,662 B1 | 11/2001 | Ellis               |
| 5,809,190 A | 9/1998  | Chen                | 6,326,245 B1 | 12/2001 | Farnworth et al.    |
| 5,813,141 A | 9/1998  | Cho                 | 6,351,853 B1 | 3/2002  | Halstead et al.     |
|             |         |                     | 6,360,453 B1 | 3/2002  | Ellis               |
|             |         |                     | 6,360,457 B1 | 3/2002  | Qui et al.          |
|             |         |                     | 6,366,472 B2 | 4/2002  | Alina et al.        |
|             |         |                     | 6,391,405 B1 | 5/2002  | Bonk et al.         |

(56)

References Cited

U.S. PATENT DOCUMENTS

6,440,775 B2 8/2002 Khoury  
 6,446,271 B1 9/2002 Ho  
 6,457,261 B1 10/2002 Crary  
 6,487,795 B1 12/2002 Ellis  
 6,493,881 B1 12/2002 Picotte  
 6,519,780 B2 2/2003 Goodwin  
 6,530,092 B2 3/2003 Pope  
 6,537,639 B1 3/2003 Huang  
 6,571,490 B2 6/2003 Tawney et al.  
 6,584,706 B1 7/2003 Ellis  
 6,591,428 B2 7/2003 Halstead et al.  
 6,591,429 B1 7/2003 Jaszai  
 6,591,519 B1 7/2003 Ellis  
 6,629,376 B1 10/2003 Ellis  
 6,645,832 B2 11/2003 Kim et al.  
 6,658,671 B1 12/2003 Von Holst et al.  
 6,662,470 B2 12/2003 Ellis  
 6,668,470 B2 12/2003 Ellis  
 6,675,498 B1 1/2004 Ellis  
 6,675,499 B2 1/2004 Ellis  
 6,681,408 B2 1/2004 Ku  
 6,708,424 B1 3/2004 Ellis  
 6,722,058 B2 4/2004 Lucas et al.  
 6,725,250 B1 4/2004 Ellis  
 6,729,046 B2 5/2004 Ellis  
 6,732,141 B2 5/2004 Ellis  
 6,748,674 B2 6/2004 Ellis  
 6,763,616 B2 7/2004 Ellis  
 6,772,347 B1 8/2004 Xie et al.  
 6,789,331 B1 9/2004 Ellis  
 6,795,625 B1 9/2004 Ishii et al.  
 6,797,545 B2 9/2004 Farnworth et al.  
 6,810,606 B1 11/2004 Rapaport  
 D500,585 S 1/2005 Yung-Mao  
 6,837,951 B2 1/2005 Litchfield et al.  
 6,845,573 B2 1/2005 Litchfield et al.  
 6,846,534 B2 1/2005 Aveni et al.  
 6,848,200 B1 2/2005 Westin  
 6,851,204 B2 2/2005 Bonk et al.  
 6,877,254 B2 4/2005 Ellis  
 6,918,197 B2 7/2005 Ellis  
 6,946,050 B2 9/2005 Dojan et al.  
 6,950,947 B1 9/2005 Purtell et al.  
 6,957,000 B2 10/2005 McAlpine et al.  
 6,971,193 B1 12/2005 Potter et al.  
 6,976,321 B1 12/2005 Lakic  
 6,990,755 B2 1/2006 Hatfield et al.  
 7,010,869 B1 3/2006 Ellis  
 7,024,449 B1 4/2006 Ellis  
 7,035,906 B1 4/2006 Ellis  
 7,037,571 B2 5/2006 Fish et al.  
 7,047,275 B1 5/2006 Ellis  
 7,076,890 B2 7/2006 Grove et al.  
 7,082,697 B2 8/2006 Ellis  
 7,086,179 B2 8/2006 Dojan et al.  
 7,093,379 B2 8/2006 Ellis  
 7,123,801 B2 10/2006 Fitz  
 7,127,834 B2 10/2006 Ellis  
 7,132,032 B2 11/2006 Tawney et al.  
 7,140,129 B2 11/2006 Newson et al.  
 7,148,565 B2 12/2006 Kim et al.  
 7,161,175 B2 1/2007 Shau  
 7,168,185 B2 1/2007 Ellis  
 7,168,188 B2 1/2007 Auger et al.  
 7,174,658 B2 2/2007 Ellis  
 7,194,826 B2 3/2007 Ungari  
 7,234,249 B2 6/2007 Ellis  
 7,264,908 B2 9/2007 Kaneko et al.  
 7,287,341 B2 10/2007 Ellis  
 7,334,349 B2 2/2008 Sokolowski et al.  
 7,334,350 B2 2/2008 Ellis  
 7,334,356 B2 2/2008 Ellis  
 7,412,588 B2 8/2008 Georgiou et al.  
 7,484,318 B2 2/2009 Finkelstein  
 7,506,020 B2 3/2009 Ellis

7,546,699 B2 6/2009 Ellis  
 7,562,468 B2 7/2009 Ellis  
 7,591,084 B2 9/2009 Santa Ana  
 7,606,854 B2 10/2009 Ellis  
 7,634,529 B2 12/2009 Ellis  
 7,647,710 B2 1/2010 Ellis  
 7,707,742 B2 5/2010 Ellis  
 7,793,429 B2 9/2010 Ellis  
 7,793,430 B2 9/2010 Ellis  
 7,805,756 B2 9/2010 Ellis  
 7,814,233 B2 10/2010 Ellis  
 7,908,650 B2 3/2011 Ellis  
 7,926,097 B2 4/2011 Ellis  
 8,125,796 B2\* 2/2012 Ellis ..... 361/818  
 8,141,276 B2 3/2012 Ellis  
 8,164,170 B2\* 4/2012 Ellis ..... 257/682  
 8,378,474 B2\* 2/2013 Ellis ..... 257/682  
 2001/0032351 A1 10/2001 Nakayama et al.  
 2001/0046119 A1 11/2001 Hamano et al.  
 2002/0002730 A1 1/2002 Dennis et al.  
 2002/0023291 A1 2/2002 Mendoza  
 2002/0152541 A1 10/2002 Halstead et al.  
 2002/0152542 A1 10/2002 Dennis et al.  
 2002/0166157 A1 11/2002 Pope  
 2003/0046830 A1 3/2003 Ellis, III  
 2003/0079276 A1 5/2003 Forsyth et al.  
 2003/0096899 A1 5/2003 Pearce  
 2003/0200598 A1 10/2003 Jessie  
 2004/0215931 A1 10/2004 Ellis  
 2004/0226077 A1 11/2004 Toth  
 2005/0039346 A1 2/2005 Thomas et al.  
 2005/0076536 A1 4/2005 Hatfield et al.  
 2005/0144808 A1 7/2005 Vito et al.  
 2005/0180095 A1 8/2005 Ellis  
 2005/0246824 A1 11/2005 Berger et al.  
 2005/0262739 A1 12/2005 McDonald et al.  
 2006/0010717 A1 1/2006 Finkelstein  
 2006/0137221 A1 6/2006 Dojan et al.  
 2006/0179683 A1 8/2006 Weiss et al.  
 2006/0230636 A1 10/2006 Kokstis et al.  
 2006/0248749 A1 11/2006 Ellis  
 2007/0084081 A1 4/2007 Fallon  
 2007/0094896 A1 5/2007 Hatfield et al.  
 2007/0196948 A1 8/2007 Trezza  
 2008/0083140 A1 4/2008 Ellis  
 2008/0083976 A1 4/2008 Haba et al.  
 2008/0229614 A1 9/2008 Santa Ana  
 2009/0026524 A1 1/2009 Kreupl et al.  
 2009/0200661 A1 8/2009 Ellis  
 2012/0175752 A1\* 7/2012 Ellis ..... 257/659  
 2012/0224819 A1 9/2012 Ellis

FOREIGN PATENT DOCUMENTS

CA 1176458 10/1984  
 DE 23257 5/1956  
 DE 1888119 12/1963  
 DE 1918131 6/1965  
 DE 1918132 6/1965  
 DE 1287477 1/1969  
 DE 1290844 3/1969  
 DE 2036062 7/1970  
 DE 1948620 5/1971  
 DE 1685293 7/1971  
 DE 1685260 10/1971  
 DE 2045430 3/1972  
 DE 2522127 11/1976  
 DE 2525613 12/1976  
 DE 2602310 7/1977  
 DE 2613312 10/1977  
 DE 2706645 8/1978  
 DE 2654116 1/1979  
 DE 2737765 3/1979  
 DE 2805426 8/1979  
 DE 3021936 4/1981  
 DE 3024587 A1 1/1982  
 DE 8219616.8 9/1982  
 DE 3113295 10/1982  
 DE 3245182 5/1983

(56)

## References Cited

## FOREIGN PATENT DOCUMENTS

|    |             |         |
|----|-------------|---------|
| DE | 3317462     | 10/1983 |
| DE | 8431831.7   | 12/1984 |
| DE | 3347343     | 7/1985  |
| DE | 8530136.1   | 2/1988  |
| DE | 3629245     | 3/1988  |
| DE | 40 08 335   | 9/1991  |
| EP | 0048965     | 4/1982  |
| EP | 0083449 A1  | 12/1982 |
| EP | 0130816     | 1/1985  |
| EP | 0185781     | 7/1986  |
| EP | 0207063     | 10/1986 |
| EP | 0206511     | 12/1986 |
| EP | 0213257     | 3/1987  |
| EP | 0215974     | 4/1987  |
| EP | 0238995     | 9/1987  |
| EP | 0260777     | 3/1988  |
| EP | 0301331     | 2/1989  |
| EP | 0329391     | 8/1989  |
| EP | 0410087     | 1/1991  |
| EP | 0 647 052   | 4/1995  |
| EP | 0697825     | 2/1996  |
| EP | 0 840216    | 5/1998  |
| EP | 0 853 279   | 7/1998  |
| EP | 0910964     | 4/1999  |
| EP | 1068460     | 1/2001  |
| EP | 1374808     | 1/2004  |
| EP | 1414322     | 5/2004  |
| EP | 1480534     | 12/2004 |
| EP | 1529457     | 5/2005  |
| FR | 602501      | 3/1926  |
| FR | 925961      | 9/1947  |
| FR | 1004472     | 3/1952  |
| FR | 1245672     | 10/1960 |
| FR | 1323455     | 2/1963  |
| FR | 2006270     | 11/1972 |
| FR | 2261721     | 9/1975  |
| FR | 2511850     | 3/1983  |
| FR | 2622411     | 5/1989  |
| GB | 9591        | 0/1913  |
| GB | 16143       | 0/1892  |
| GB | 764956      | 1/1957  |
| GB | 792034      | 3/1958  |
| GB | 807 305     | 1/1959  |
| GB | 1504615     | 3/1978  |
| GB | 2 023 405   | 1/1980  |
| GB | 2 039 717   | 8/1980  |
| GB | 2076633     | 12/1981 |
| GB | 2133668     | 8/1984  |
| GB | 2 136 670   | 9/1984  |
| JP | 39-15597    | 8/1964  |
| JP | 45-5154     | 3/1970  |
| JP | 50-71132    | 11/1975 |
| JP | 57-139333   | 8/1982  |
| JP | 59-23525    | 7/1984  |
| JP | 61-55810    | 4/1986  |
| JP | 1129505     | 6/1986  |
| JP | 61-167810   | 10/1986 |
| JP | 1-195803    | 8/1989  |
| JP | 2136505     | 5/1990  |
| JP | 2279103     | 11/1990 |
| JP | 3-85102     | 4/1991  |
| JP | 3086101     | 4/1991  |
| JP | 4-279102    | 10/1992 |
| JP | 5-123204    | 5/1993  |
| NZ | 189890      | 9/1981  |
| WO | WO 87/07480 | 12/1987 |
| WO | WO 87/07481 | 12/1987 |
| WO | WO 88/08263 | 11/1988 |
| WO | WO 89/06500 | 7/1989  |
| WO | WO 90/00358 | 1/1990  |
| WO | WO 91/00698 | 1/1991  |
| WO | WO 91/03180 | 3/1991  |
| WO | WO 91/04683 | 4/1991  |
| WO | WO 91/05491 | 5/1991  |
| WO | WO 91/10377 | 7/1991  |

|    |                |         |
|----|----------------|---------|
| WO | WO 91/11124    | 8/1991  |
| WO | WO 91/11924    | 8/1991  |
| WO | WO 91/19429    | 12/1991 |
| WO | WO 92/07483    | 5/1992  |
| WO | WO 92/18024    | 10/1992 |
| WO | WO 93/13928    | 7/1993  |
| WO | WO 94/01964    | 1/1994  |
| WO | WO 94/03080    | 2/1994  |
| WO | WO 95/01060    | 1/1995  |
| WO | WO9614768      | 5/1996  |
| WO | WO 97/00029    | 1/1997  |
| WO | WO 98/26366    | 6/1998  |
| WO | WO 99/04561    | 1/1999  |
| WO | WO 99/32972    | 7/1999  |
| WO | WO 00/54616    | 9/2000  |
| WO | WO 00/64293    | 11/2000 |
| WO | WO 00/70981    | 11/2000 |
| WO | WO 01/80678    | 11/2001 |
| WO | WO 02/09547    | 2/2002  |
| WO | WO 2005/115190 | 12/2005 |
| WO | WO 2005/117628 | 12/2005 |
| WO | WO 2005/117629 | 12/2005 |
| WO | WO 2006/113212 | 10/2006 |
| WO | WO 2006/124116 | 11/2006 |
| WO | WO 2007/024523 | 3/2007  |

## OTHER PUBLICATIONS

adidas Catalog 1986.  
adidas Catalog 1988.  
adidas Catalog 1989.  
adidas Catalog 1990.  
adidas Catalog 1991.  
adidas Catalog, Spring 1987.  
adidas' Second Supplemental Responses to Interrogatory No. 1.  
adidas shoe, Model "Buffalo" 1985.  
adidas shoe, Model "London", 1986.  
adidas shoe, Model "Marathon 86" 1985.  
adidas shoe, Model "Skin Racer", 1988.  
adidas shoe, Model "Tokio H" 1985.  
adidas shoe, Model "Torsion Grand Slam Indoor," 1989.  
adidas shoe, Model <<Boston Super>> 1985.  
adidas shoe, Model <<Fire>> 1985.  
adidas shoe, Model <<Indoor Pro>> 1987.  
adidas shoe, Model <<Kingscup Indoor>>, 1986.  
adidas shoe, Model <<Marathon>> 1986.  
adidas shoe, Model <<Questar>>, 1986.  
adidas shoe, Model <<Tauern>> 1986.  
adidas shoe, Model <<Tennis Comfort>>, 1988.  
adidas shoe, Model <<Torsion Special HI>> 1989.  
adidas shoe, Model <<Torsion ZX9020S>> 1989.  
adidas shoe, Model <<Water Competition>> 1980.  
adidas shoe, Model, <<Indoor Pro>> 1987.  
adidas Spring Catalog 1989.  
Areblad et al. <<Three-Dimensional Measurement of Rearfoot Motion During Running>> *Journal of Biomechanics*, vol. 23, vol. 9, pp. 933-940 (1990).  
AVIA Catalog 1986.  
Avia Fall Catalog, 1988.  
Brooks Catalog 1986.  
Cavanagh et al., "Biomechanics of Distance Running," Human Kinetics Books, pp. 155-164, 1990.  
Clark Shoe Designed by Sven Coomer 1991.  
Fineagan, "Comparison of the Effects of a Running Shoe and a Racing Flat on the Lower Extremity Biochemical Alignment of Runners," *Journal of the American Physical Therapy Association*, vol. 68, No. 5, p. 806 (1988).  
Fixx, *The Complete Book of Running*, pp. 134-137, 1977.  
Footwear Journal, Nike Advertisement, Aug. 1987.  
Footwear News, vol. 44, No. 37, Nike Advertisement (1988).  
Footwear News, Special Supplement, Feb. 8, 1988.  
Footwear News, vol. 45, No. 5, Nike Advertisement 1989.  
Frederick, *Sports Shoes and Playing Surfaces, Biomechanical Properties*, Entire Book, 1984.

(56)

## References Cited

## OTHER PUBLICATIONS

- Johnson et al., <<A Biomechanical Approach to the Design of Football Boots>>, *Journal of Biomechanics*, vol. 9, pp. 581-585 (1976).
- Komi et al., "Interaction Between Man and Shoe in Running: Considerations for More Comprehensive Measurement Approach," *International Journal of Sports Medicine*, vol. 8, pp. 196-202 1987.
- Kronos Catalog, 1988.
- K-Swiss Catalog, Fall 1991.
- Leuthi et al., <<Influence of Shoe Construction on Lower Extremity Kinematics and Load During Lateral Movements in Tennis>>, *International Journal of Sport Biomechanics*, vol. 2, pp. 166-174, 1986.
- Nawoczinski et al., <<Effect of Rocker Sole Design on Plantar Forefoot Pressures>>*Journal of the American Podiatric Medical Association*, vol. 79, No. 9, pp. 455-460, 1988.
- Nigg et al., "Biomechanical Aspects of Sport Shoes and Playing Surfaces," Proceedings of the International Symposium on Biomechanical Aspects of Sport Shoes and Playing Surfaces, 1983.
- Nigg et al., "Influence of Heel Flare and Midsole Constructions on Pronation" *International Journal of Sport Biomechanics*, vol. 4, No. 3, pp. 205-219 (1987).
- Nigg et al., <<The Influence of Lateral Heel Flare of Running Shoes on Pronation and Impact Forces>>, *Medicine and Science in Sports and Exercise*, vol. 19, No. 3, pp. 294-302, 1987.
- Nigg et al., *Biomechanics of Running Shoes*, entire book, 1986.
- Nigg, <<Biomechanical Analysis of Ankle and foot Movement>>*Medicine and Sport Science*, vol. 23, pp. 22-29 1987.
- Nike Catalog, Footwear Fall, 1988.
- Nike Fall Catalog 1987, pp. 50-51.
- Nike Shoe, men's cross-training Model "Air Trainer SC" 1989.
- Nike shoe, men's cross-training Model <<Air Trainer TW>> 1989.
- Nike shoe, Model "Air Force" #1978, 1988.
- Nike shoe, Model "Air" #1553, 1988.
- Nike shoe, Model <<Air Flow>> #718, 1988.
- Nike shoe, Model <<Air Revolution>> #15075, 1988.
- Nike shoe, Model <<Air>>, #13213, 1988.
- Nike shoe, Model <<Air>>, #4183, 1988.
- Nike shoe, Model <<High Jump 88>>, 1988.
- Nike shoe, Model <<Leather Cortex®>>, 1988.
- Nike shoe, Model <<Zoom Street Leather>> 1988.
- Nike Spring Catalog 1989 pp. 62-63.
- Palamarchuk et al., "In shoe Casting Technique for Specialized Sport Shoes," *Journal of the American Podiatric Medical Association*, vol. 79, No. 9, pp. 462-465, 1989.
- Prince Cross-Sport 1989.
- Puma basketball shoe, *The Complete Handbook of Athletic Footwear*, pp. 315, 1987.
- Romika Catalog, Summer 1978.
- Runner's World, "Shoe Review" Nov. 1988 pp. 46-74.
- Runner's World, "Spring Shoe Survey," pp. 45-74, 1989.
- Runner's World, Apr. 1988.
- Runner's World, Oct. 1986.
- Saucony Spot-bilt Catalog 1988.
- Saucony Spot-bilt Catalog Supplement, Spring 1985.
- Saucony Spot-bilt shoe, *The Complete Handbook of Athletic Footwear*, pp.332, 1987.
- Segesser et al., "Surfing Shoe," *The Shoe in Sport*, 1989, (Translation of a book published in Germany in 1987), pp. 106-110.
- Sporting Goods Business, Aug. 1987.
- Sports Illustrated, Nike Advertisement, Aug. 8, 1988.
- Sports Illustrated, Special Preview Issue, The Summer Olympics <<Seoul '88>> Reebok Advertisement.
- The Complete Handbook of Athletic Footwear*, Entire Book, 1987.
- Vagenas et al., "Evaluation of Rearfoot Asymmetries in Running with Worn and New Running Shoes," *International Journal of Sport Biomechanics*, vol. 4, No. 3, pp. 220-230 (1988).
- Valiant et al., <<A Study of Landing from a Jump: Implications for the Design of a Basketball Shoe>>, *Scientific Program of IX International Congress of Biomechanics*, 1983.
- Williams et al., <<The Mechanics of Foot Action During the Golf Swing and Implications for Shoe Design>>, *Medicine and Science in Sports and Exercise*, vol. 15, No. 3, pp. 247-255, 1983.
- World Professional Squash Association Pro Tour Program, 1982-1983.
- Williams, Walking on Air, *Case Alumnus*, vol. LXVII, No. 6, Fall 1989, pp. 4-8.
- Brooks advertisement in *Runner's World* etc., Jun. 1989, pp. 56+.
- Cavanaugh et al., Biological Aspects of Modeling Shoe/Foot Interaction During Running, *Sports Shoes and Playing Surfaces*, 1984, pp. 24-25, 32-35, 46.
- Blechschildt, The Structure of the Calcaneal Padding, *Foot & Ankle* vol. 2, No. 5, Mar. 1982, pp. 260-283.
- Cavanaugh "The Running Shoe Book," © 1980, pp. 176-180, Anderson World, Inc., Mountain View, CA.
- Executive Summary with Seven Figures, 1993.
- German Description of adidas badminton shoe, pre-1989(?), 1 page.
- The Reebok Lineup, Fall 1987, 2 pages.
- European Search Report EP-05825112.5-2318 (Jul. 14, 2010).
- Examiner's Comments, European Search Report EP-05825112.5-2318 (Jul. 14, 2010).
- Complete file history for U.S. Appl. No. 12/292,769.
- Complete file history for U.S. Appl. No. 12/292,553.
- Complete file history for U.S. Appl. No. 09/908,688.
- Complete file history for U.S. Appl. No. 08/477,640.
- Complete file history for U.S. Appl. No. 09/648,792.
- Complete file history for U.S. Appl. No. 08/376,661.
- Complete file history for U.S. Appl. No. 09/710,952.
- Complete file history for U.S. Appl. No. 09/780,450.
- Complete file history for U.S. Appl. No. 09/790,626.
- Complete file history for U.S. Appl. No. 09/734,905.
- Complete file history for U.S. Appl. No. 09/907,598.
- Complete file history for U.S. Appl. No. 09/794,943.
- Complete file history for U.S. Appl. No. 09/974,786.
- Complete file history for U.S. Appl. No. 08/452,490.
- Complete file history for U.S. Appl. No. 08/482,838.
- Complete file history for U.S. Appl. No. 08/033,468.
- Complete file history for U.S. Appl. No. 08/462,531.
- Complete file history for U.S. Appl. No. 11/831,645.
- Complete file history for U.S. Appl. No. 11/738,947.
- Complete file history for U.S. Appl. No. 11/179,887.
- Complete file history for U.S. Appl. No. 11/282,665.
- Complete file history for U.S. Appl. No. 11/190,087.
- Complete file history for U.S. Appl. No. 11/831,597.
- Litzkow, et al., "Condor-A Hunter of Idle Workstations", 1988 IEEE, pp. 104-111.
- Theimer, et al., "Finding Idle Machines in a Workstation-Based Distributed System", IEEE Transactions on Software Engineering, Nov. 1989, vol. 15, No. 11, pp. 1444-1458.
- Brown et al., Special Edition Using Netscape TM 2 Second Edition, Que Corporation, 1995, Ch. 1-2.
- Gilder, "Angst and Awe on the Internet by George Gilder", Forbes ASAP, Dec. 4, 1995.
- Tandiary, et al., "Batrun: Utilizing Idle Workstations for Large-scale Computing", Summer 1996, pp. 41-48.
- Brisbin, "Shopping for Internet Access", MacUser, Dec. 1994, v.10, p. 133(2).
- Gilder, "The Bandwidth Tidal Wave", Forbes ASAP, Dec. 5, 1994.
- N/A, "Special Report—Wonder Chips", Business Week, Jul. 4, 1994.
- N/A, "Supercomputers Divide and Conquer", The Economist, Dec. 14, 1996.
- N/A, "Cyber View World Widgets", Scientific American, May 1997, p. 48.
- Gibbs, "Bandwidth, Unlimited", Scientific American, Jan. 1997, p. 41.
- Markoff, "A New Standard to Govern PC's with Multiple Chips, Work Stations Mimicking Supercomputers", The New York Times, Oct. 28, 1997.
- N/A, "Aliens on your desktop", The Economist, Apr. 18, 1998, p. 78.
- Fox et al., Petaops and Exaops: Supercomputing on the Web, "IEEE Internet Computing", vol. 1 No. 2 Mar.-Apr. 1997, pp. 38-46.

(56)

## References Cited

## OTHER PUBLICATIONS

- Dincer et al., Building a World-Wide Virtual Machine Based on Web and HPC Technologies, "Student Technical Papers", <http://www.supercomp.org/sc96/proceedings/SC96PROC/DINCER/INDEX.HTM>, pp. 1-18 (1996).
- Hobbs et al., A Remote Process Creation and Execution Facility Supporting Parallel Execution on Distributed Systems, "IEEE 1996", pp. 92-99.
- Boku et al., The Architecture of Massively Parallel Processor CP-PACS, "IEEE 1997", pp. 31-40.
- Choi et al., A Diagnostic Network for Massively Parallel Processing Systems, "IEEE 1994", pp. 348-353.
- Bellovin et al., Network Firewalls, "IEEE Communications Magazine 1994", pp. 50-57.
- Weiyi et al., "Java-To-Go—Iterative Computing Using Java", Sep. 10, 1996 <http://ptolemy.eecs.berkeley.edu/dgm/javatools/java-to-go/>.
- Sullivan et al., "A New Major SETI Project Based on Project Serendip Data and 100,000 Personal Computers". [http://setiathome.ss/berkeley.edu/woody\\_paper.htm/](http://setiathome.ss/berkeley.edu/woody_paper.htm/); (1997).
- "Ein-Chip-Firewall", Elektroniknet Top News, XP-002164257; Mar. 31, 1999.
- "Means for Implementing Optical Interconnections for Parallel Processors", IBM Technical Disclosure Bulletin, Apr. 1991, vol. 33, No. 11, pp. 56-58, XP 000110310.
- Alexandrov et al., "SuperWeb: Research Issues in Java-Based Global Computing", Concurrency, vol. 9, No. 6, Jun. 1997, pp. 535-553.
- Baratioo et al., "Charlotte: Metacomputing on the Web", 9th International Conference on Parallel and Distributed Computing Systems (PDCS), 1996, pp. 1-8.
- Bevinakoppa et al., "Digital Image Compression on a Network of Transputers", Proc. of 5th Australian Transputer & OCCAM User Group Conference, IOS Press, Amsterdam, pp. 25-32; Nov. 4, 1992.
- Blumofe, R. et al., "Scheduling Large-Scale Parallel Computations on Networks of Workstations", Proc. of the 3rd IEEE Int'l Sump on High Performance Distributed Computing, pp. 96-105, Aug. 1994.
- Fields, Scott, "Hunting for Wasted Computing Power—New Software for Computing Networks Plus Idle PC's to Work", 1993 University of Wisconsin—Madison. Internet: <http://www.cs.wise.edu/condor/doc/Wiseidea.html>.
- Brecht et al., "ParaWeb: Towards World-Wide Supercomputing", Proceedings of the Seventh AcM SIGOPS European Workshop, Sep. 1996, 8 pgs.
- Capello et al., "Market-Based Massively Parallel Internet Computing", Proceedings Third Working Conference on Massively Parallel Programming Models, 1998, pp. 118-129.
- Celenk, M. et al., "Parallel Task Execution in LANs and Performance Analysis", Proc. of the 1995 IEEE 14th Annual Int'l Phoenix Conf. on Computers and Communications, pp. 423-429, Mar. 1995.
- Chen, C. et al., "The DBC: Processing Scientific Data Over the Internet", Proc of the 16th Int'l Conf. on Distributed Computing Systems, pp. 673-679, May 1996.
- Clark, H. et al., "DAWGS-A Distributed Computer Server Utilizing Idle Workstations", Proc. of the 5th Distributed Memory Computing Conf., IEEE, pp. 732-741, Apr. 1990.
- Fogg, C., "Survey of Software and Hardware VLC Architectures", SPIE, vol. 2186, Image and Video Compression (1994), pp. 29-37.
- Fox et al., "Towards Web/Java based High Performance Distributed Computing—an Evolving Virtual Machine"; as presented at 5th IEEE Int'l Symposium on High Performance Distributed Computing, Aug. 6-9; 1996, 86 pages.
- Fox, E., "Advances in Interactive Digital Multimedia Systems", Computer, Oct. 1991, pp. 9-21.
- Gemmell, et al., "Multimedia Storage Servers: a Tutorial", Computer, May 1995, pp. 40-49.
- Hayes, "Computing Science: Collective Wisdom", American Scientist, Mar.-Apr. 1998, pp. 1-8.
- Kim, B., "ATM Network: Goals and Challenges", Communications of the ACM, Feb. 1995, vol. 38, No. 2, pp. 39-44, 109.
- Kremien, O., "Buying and Selling Computational Power Over the Network", Proc. of the 4th int'l Conf. on Computer Communications and Networks, IEEE, pp. 616-619, Sep. 1995.
- Lindley, C., "JPEG-Like Image Compression, Part 2", Dr. Dobb's Journal, Aug. 1995, pp. 62-66, 102-105.
- Lindley, C., "JPEG-Like Image Compression, Part 1", Dr. Dobb's Journal, Jul. 1995, pp. 50-58, 101-102.
- Morris, J. et al., "Fault Tolerant Networks of Workstations", Proc. of the 3rd Int'l Conf. on High Performance Computing, IEEE, pp. 271-276, Dec. 1996.
- Nass, R., "Hardware-software combo could simplify MPEG real-time video compression", Electronic Design, May 3, 1993, p. 36.
- Nowatzyk et al., "Are Crossbars Really Dead? The Case for Optical Multiprocessor Interconnect Systems", Proceedings of the Annual Symposium on Computer Architecture, ACM, vol. 22, Jun. 1995, pp. 106-115, XP 000687800.
- Ozer, "Digital Video: Shot by Shot", PC Magazine, Apr. 11, 1995, pp. 104-107, 110.
- Ozer, J., "Why MPEG is Hot", PC Magazine, Apr. 11, 1995, pp. 130-131.
- Plotkin, "The Digital Compression Facility—A Solution to Today's Compression Needs", 1994 IEEE, pp. 445-449.
- Qiao et al., "Time-Division Optical Communications in Multiprocessor Arrays", ACM, 1991, pp. 644-653, XP 000337522.
- Rincon et al., "The Changing Landscape of System-on-a-chip Design", MicroNews, Third Quarter 1999, [www.chips.ibm.com/micronews/vol5\\_no3/rincon.html](http://www.chips.ibm.com/micronews/vol5_no3/rincon.html), pp. 1-10, vol. 5, No. 3.
- Sachs, M. et al., "LAN and I/O Convergence: A Survey of the issues", Computer, Dec. 1994, pp. 24-32.
- Sakano, et al., "A Three-Dimensional Mesh Multiprocessor System Using Board-to-Board Free-Space Optical Interconnects: COSINE-III", IEEE, 1993, pp. 278-283, XP 000463415.
- Schroeder, E., "New Offerings Buoy MPEG as Video Standard", Desktop Computing, PC Week, May 8, 1995, pp. 1 and 29.
- Shen et al., "A Parallel Implementation of an MPEG1 Encoder: Faster than Real-Time!", Proc. of SPIE Conf. on Digital Video Compression, San Jose, CA, Feb. 1995.
- McHenry et al., "An FPGA-Based Coprocessor for ATM Firewalls", Field-Programmable Custom Computing Machines 1997, Apr. 16-18, 1997, pp. 30-39, XP-002157218.
- Shiuan, J. et al., "Client-Server Based Ray-Tracer Using ASTRA. An Asynchronous RPC Mechanism", Computer Communications, vol. 19, No. 5, pp. 445-455, May 1996.
- Szabo, B. et al., "Design Considerations for JPEG Video and Synchronized Audio in a Unix Workstation Environment", USENIX-Summer '91, pp. 353-368.
- Vetter, R., "ATM Concepts, Architectures, and Protocols", Communications of the ACM, Feb. 1995, vol. 38, No. 2, pp. 30-38, 109.
- Vetter, R. et al., "Issues and Challenges in ATM Networks", Communications of the ACM, Feb. 1995; vol. 38, No. 2, pp. 28-29.
- Waldspurger et al., "Spawn: A Distributed Computational Economy", IEEE Transactions on Software Engineering, vol. 18, No. 2, Feb. 1992, pp. 103-117 XP002124500.
- Yoshida, J., "MPEG-2 Encoders Make Show of Force at NAB", Electronic Engineering Times, Apr. 10, 1995.
- Yu, Y. et al., "Software Implementation of MPEG-II Video Encoding Using Socket Programming in LAN", SPIE vol. 2187, pp. 229-240, 1994.
- Waltz et al., "Make em pay: Billing Net Usage", MacWeek, vol. 6 (No. 27), p. 24 (2) (Dialog full text), (Jul. 27, 1992).
- "The Economics Systems of Network Billing: Network Billing and Monitoring Systems can Improve Efficiency and Cut Costs", IBM System User, vol. 14 (No. 11), p. 53 (1) (Dialog Fulltext), (Nov. 1993).
- "Let Your Computer Make Money While You Sleep", Newsbytes, p. 1 (Dialog Fulltext), (Aug. 16, 1996).
- Regenold et al., "A Single-Chip Multiprocessor DSP Solution for Communication Applications", ASIC Conference and Exhibit 1994, pp. 437-440.
- Geppert, L. Solid State [Trend/Development], IEEE Spectrum, v. 33, iss. 1, 1996, pp. 51-55.



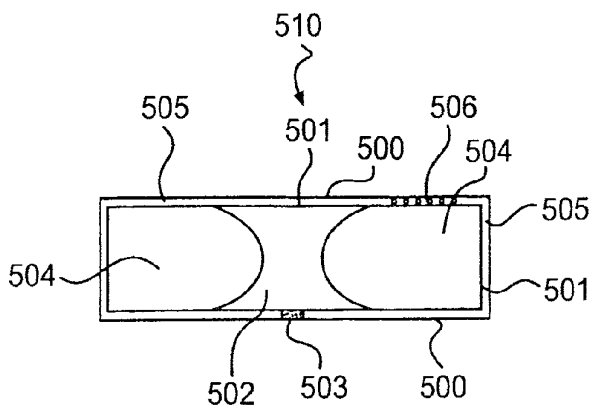
(56)

**References Cited**

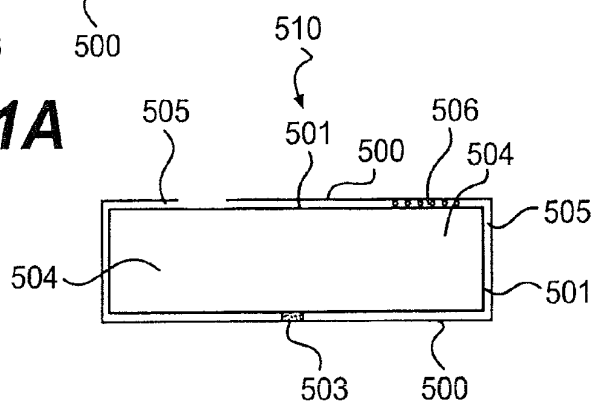
## OTHER PUBLICATIONS

- Li, Yao, "Free-space Optical Bus-based WDMA Interconnects for Parallel Computation", LEOS '92 Conference Proceedings, Lasers and Electron-Optics Society Annual Meeting, p. 588-589, Nov. 16-19, 1992.
- Dickinson et al., "An Integrated Free Space Optical Bus", 1989 IEEE International Conference on Computer Design, VLSI in Computers and Processors, p. 62-65, Oct. 2-4, 1989.
- Natarajan et al., "Bi-Directional Optical Backplane Bus for General Purpose Multi-Processor", Journal of Lightwave Technology, vol. 13, No. 6, p. 1031-1040, Jun. 6, 1995.
- Zhao et al., "General Purpose Bidirectional Optical Backplane: High Performance Bus for Multiprocessor Systems", Massively Parallel Processing Using Optical Interconnections, 2nd International Conference, p. 188-195, Oct. 23-24, 1995.
- Wu et al., "Microprocessor Control Signal Transmission Through Optical Fiber", Conference Record of 1992, IEEE Industry Applications Society Annual Meeting, p. 1747-1750, Oct. 4-9, 1992.
- Fox et al., "Towards Web/Java based High Performance Distributed Computing-an Evolving Virtual Machine", www.npac.syr.edu/projects/webpace/doc/hpdc5/paper, Jun. 10, 1996, 11 pages.
- None, "PC Vision: Intel unveils plans to bring PCs to Vehicles"; EDGE: Work-Group Computing Report, EDGE Publishing, p. 1-2 (Oct. 28, 1996).
- The American Heritage College Dictionary 4th Ed—definition of "firewall" (2007).
- White, "Covert Distributed Processing with Computer Viruses", Advances in Cryptology, Crypto 89, Springer LNCS, v. 435, pp. 616-619 (1990).
- Foster et al., "The Grid: Blueprint for a New Computing Infrastructure", Morgan Kaufmann Publishers, Inc., 1998.
- Hwang et al., "Scalable Parallel Computing", WCB McGraw-Hill, 1998.
- Wilkinson, et al., "Parallel Programming", Prentice Hall, 1998.
- Patterson et al., "Computer Architecture: A Quantitative Approach" (2nd Edition), Morgan Kaufmann Publishers, Inc., 1996.
- Culler et al., "Parallel Computer Architecture", Morgan Kaufmann Publishers, Inc., 1998.
- Hennessy et al., "Computer Organization and Design", Morgan Kaufmann Publishers, Inc., 1998.
- Slater, "The Microprocessor Today", IEEE Micro 1996, pp. 32-44.
- Steinert-Threlkeld, "New Breed of Chip TI develops a super circuit"; The Sun Baltimore; May 4, 1992.
- Dallas Morning News; "LSI holds big plans for tiny chips Versatility of 'system on a chip' creates niche in microelectronics;" Mar. 4, 1996.
- Mokhoff; "System-on-a-chip comes to wireless arena;" Electronic Engineering Times; Feb. 12, 1996.
- Cindi; "System on a Chip stars at ISSCC;" Electronic News; Feb. 19, 1996.
- Ang; "System-on-a-chip to define next-generation set-top box"; Electronic Engineering Times; Dec. 15, 1995.
- Marc; "New family of microprocessor cores from LSI Logic extends customers system-on-a-chip design capability" Nov. 7, 1994.
- Wall Street Journal; "Technology Brief—Advance Micro Devices Inc.; Company unveils Microchip for Hand-Held Computers"; Oct. 18, 1993.
- Gelsinger, Patrick et al. "Microprocessors circa 2000," IEEE Spectrum, Oct. 1989 pp. 43-47.
- Yu, Albert. "The Future of Microprocessors," IEEE Micro, Dec. 1996, pp. 46-53.
- McWilliams. "Dell to Phase Out Computers Using Intel's Itanium," The Wall Street Journal, Online, Sep. 15, 2005.
- David Pescovitz, "Power of the PC", Scientific American, pp. 27-28 (Apr. 2000).
- Stephen H. Wildstrom, "The Problem with Firewalls", Business Week, pp. 25 (Mar. 20, 2000).
- J. McH., "Build Your Own Supercomputer", FORBES, pp. 228 (Nov. 15, 1999).
- Wilkinson, Barry et al., "Parallel Programming: Techniques and Applications Using Networked Workstations and Parallel Computers", Chapter 4, Prentice-Hall, Inc., 1999.
- Baker, Lou et al., "Parallel Programming", Chapter 4, McGraw Hill Companies, Inc., 1996.
- Kayssi, A.; Harik, L.; Ferzli, R.; Fawaz, M; "FPGA-based Internet Protocol Firewall Chip"; Electronics, Circuits and Systems, 2000. ICECS 2000. The 7th IEEE International Conference on vol. 1, Dec. 17-20, 2000 pp. 316-319 vol. 1.[retrieved from IEEE database 6.9.08].
- English language abstract of EP 0 647 052, published Apr. 5, 1995.
- Newton's Telecom Dictionary, "Mobile IP", p. 459, Mar. 1998.
- Holographic Quantum Computer, <http://www.unitelnw.com/holo1/index> (May 1999).
- Jonathan Fahey, "Screen Grab", FORBES, pp. 52-53, Mar. 5, 2001.
- Ronald Grover et al., "TV GUY", Business Week, pp. 66-76, Mar. 12, 2001.
- "Distributed Computing", Red Herring, No. 87, pp. 166-202, Dec. 18, 2000.
- Om Malik, "Distributed Computing Redefines Computer Networks, Underpinning Innovation, Company Formation, and Investments", Red Herring, No. 86, pp. 95-96 and 105, Dec. 4, 2000.
- Alan Zeichick, "P2P Network Explained", Red Herring, No. 86, pp. 204 and 206, Dec. 4, 2000.
- "Napster is Clouding Grove's Crystal Ball"; FORTUNE, pp. 271-272, May 29, 2000.
- Gordon Force, Sr., "Portable Data Encryption Approaches", WESTCON/95, Conference Record; Microelectronics Communications Technology Producing Quality Production Mobile and Portable Power emerging Technologies, Nov. 7-9, 1995, pp. 413-419.
- A.D. Romig, Jr., "High Performance Microsystem Packaging: A Perspective", Microelectron Reliab., vol. 37, No. 10/11, pp. 1771-1781 (1997).

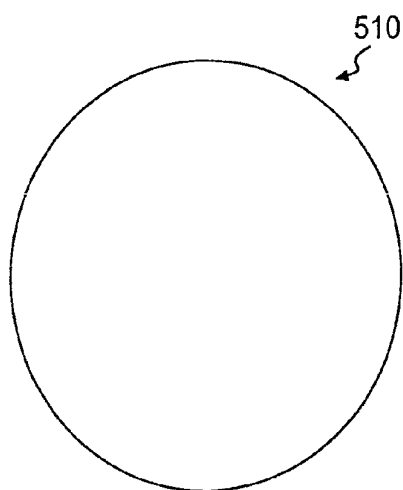
\* cited by examiner



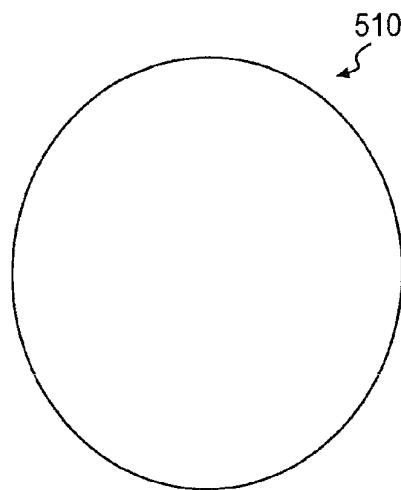
**FIG. 1A**



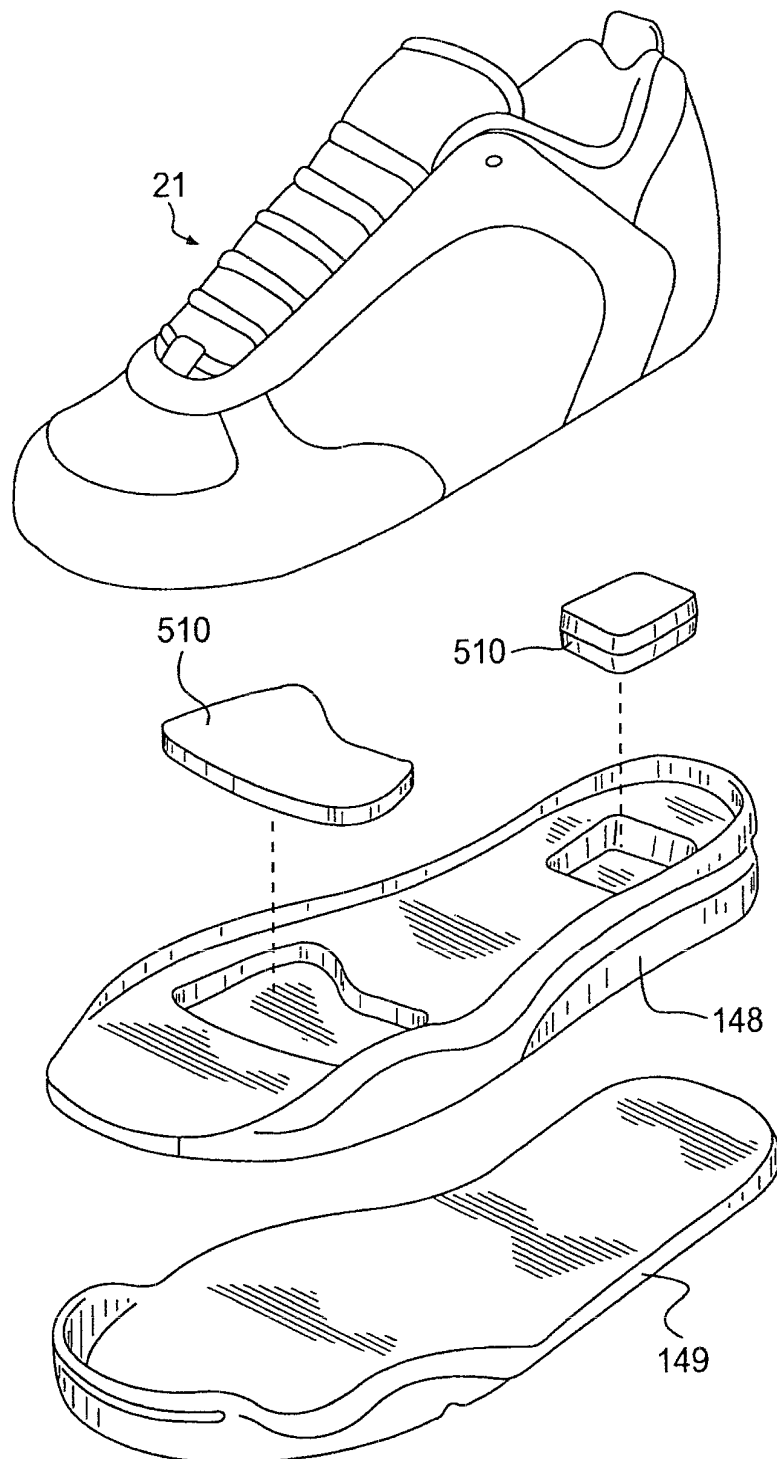
**FIG. 2A**



**FIG. 1B**

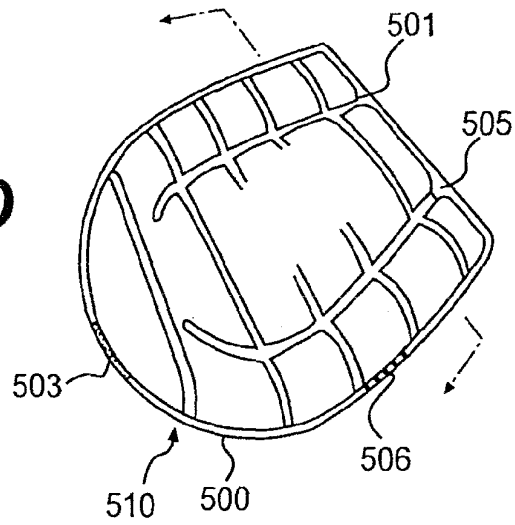


**FIG. 2B**

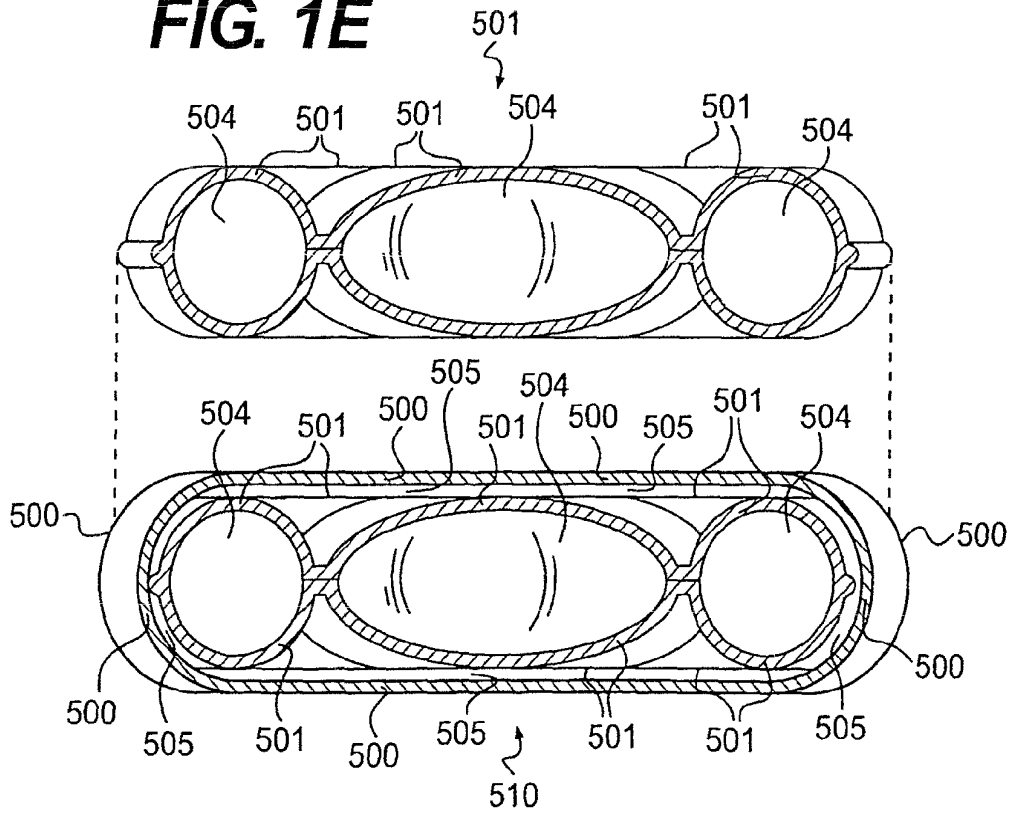


**FIG. 1C**

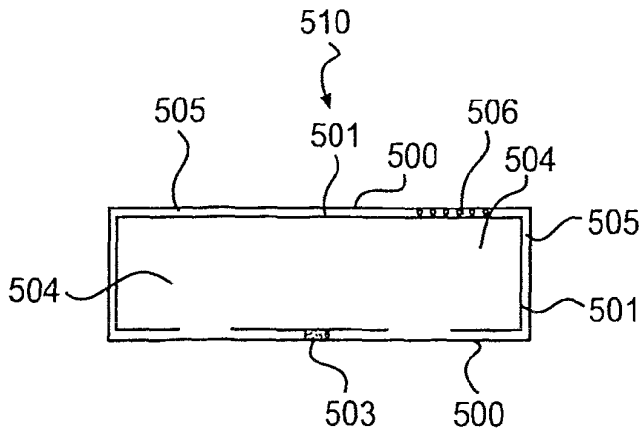
**FIG. 1D**



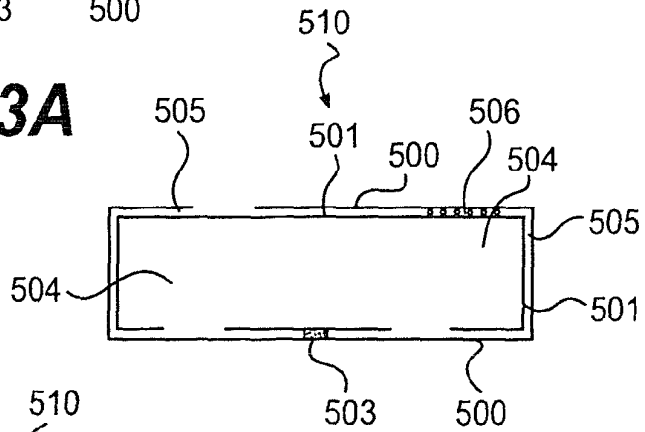
**FIG. 1E**



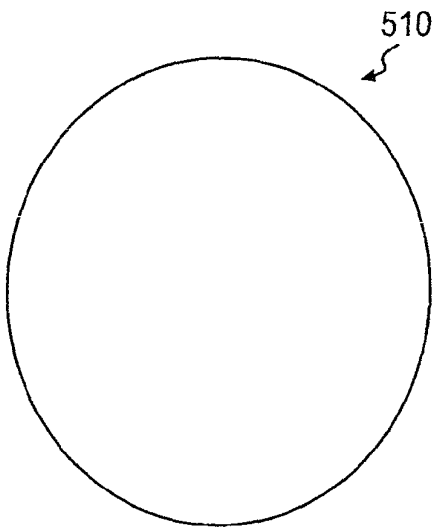
**FIG. 1F**



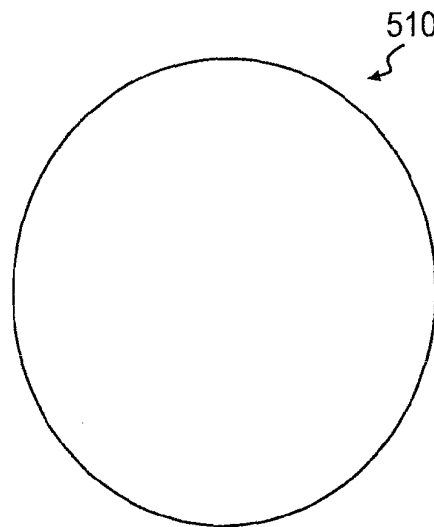
**FIG. 3A**



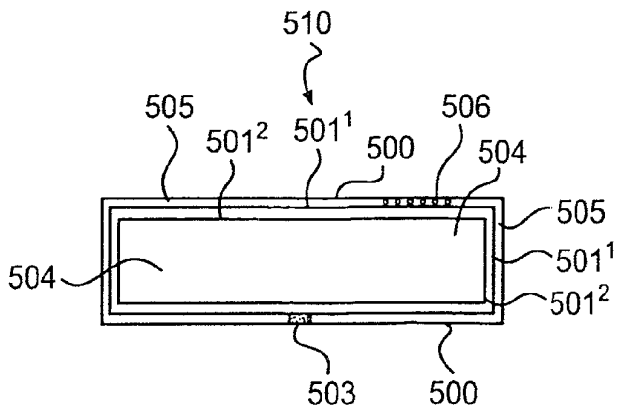
**FIG. 4A**



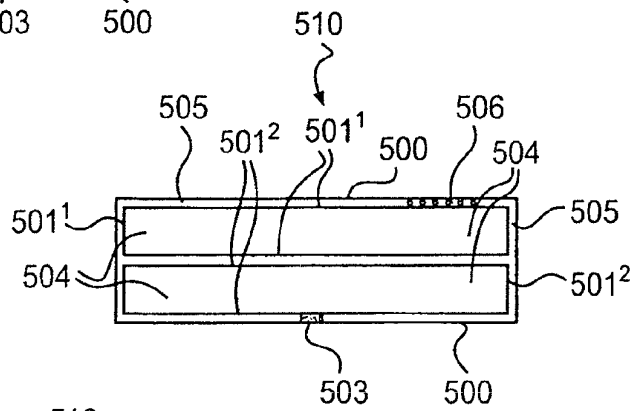
**FIG. 3B**



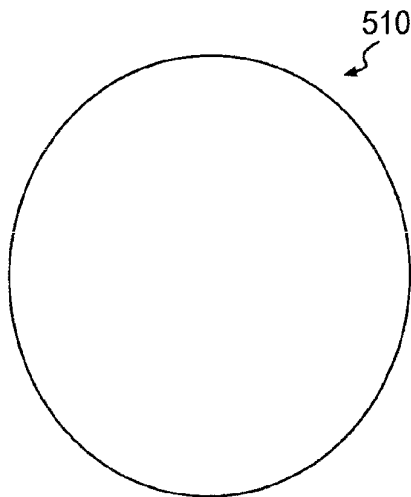
**FIG. 4B**



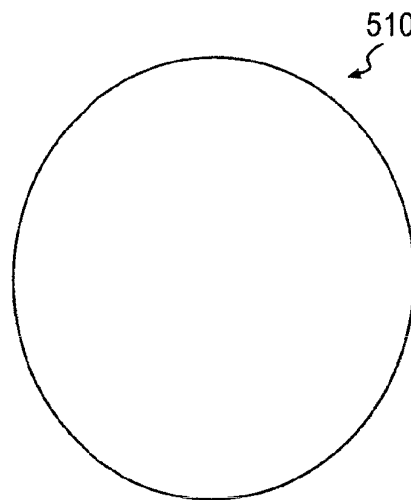
**FIG. 5A**



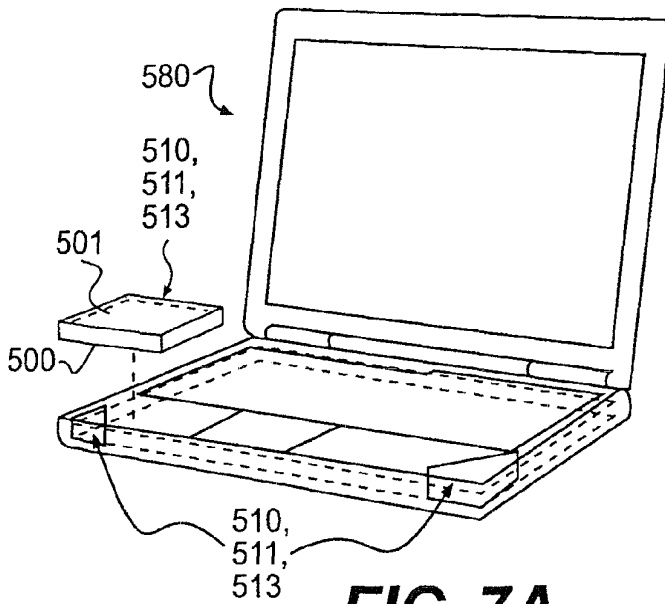
**FIG. 6A**



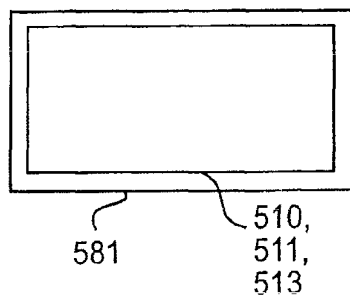
**FIG. 5B**



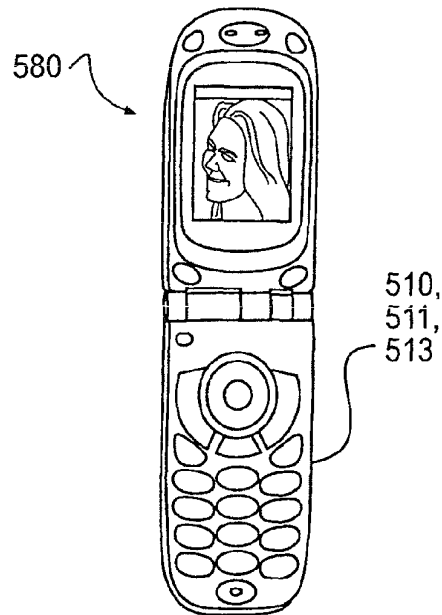
**FIG. 6B**



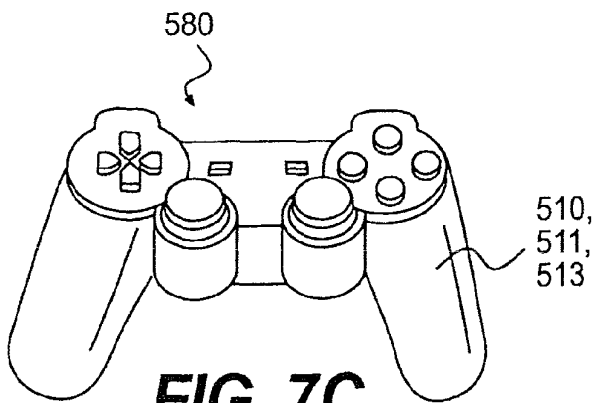
**FIG. 7A**



**FIG. 7B**



**FIG. 7D**



**FIG. 7C**

APPROXIMATE COMPARISON OF HARDNESS SCALES

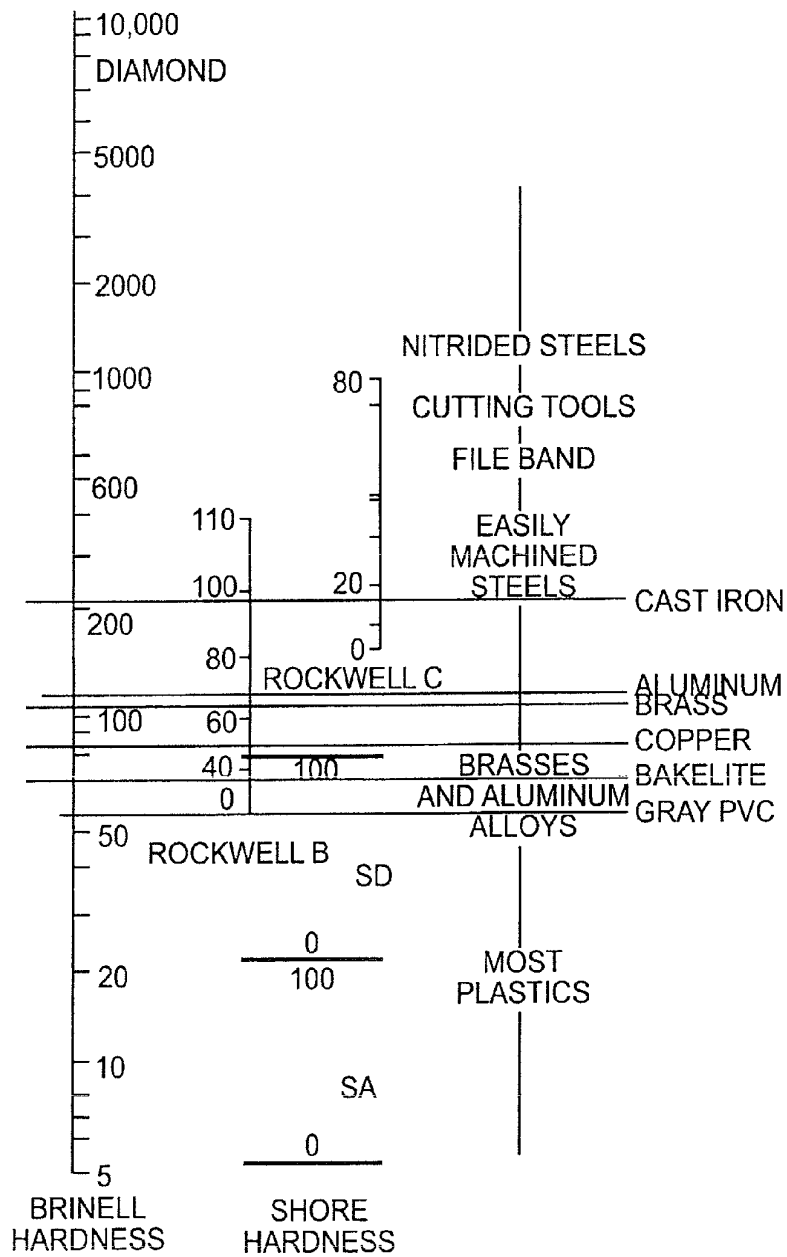
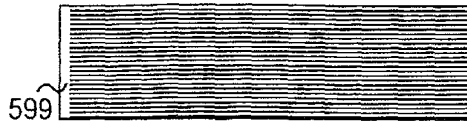


FIG. 8

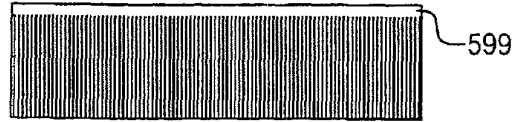




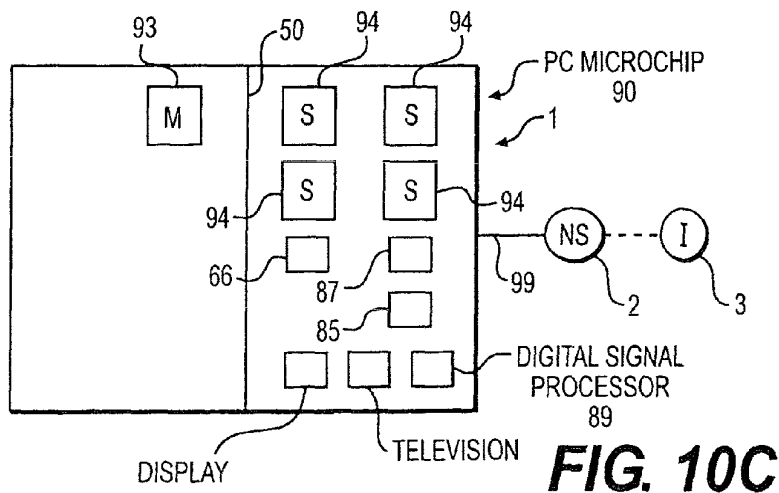
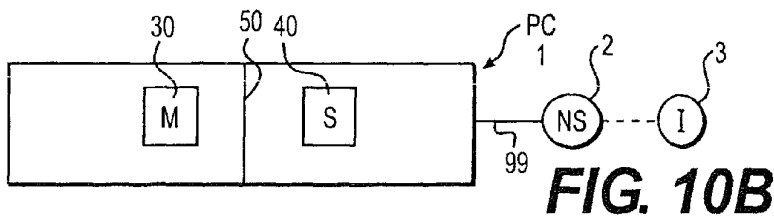
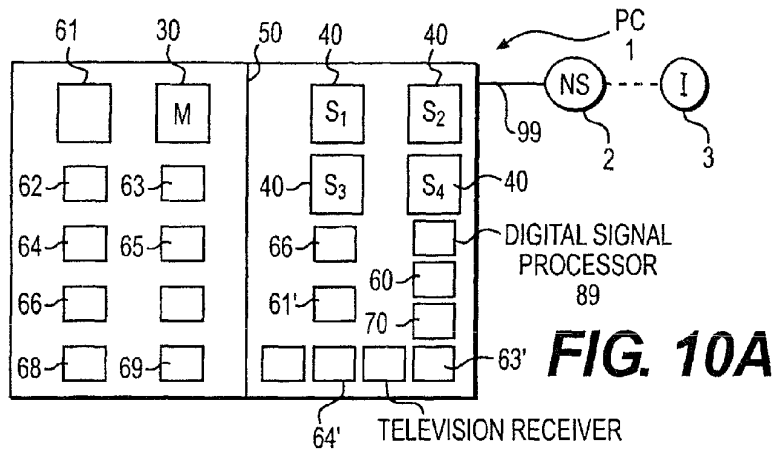
**FIG. 9A**

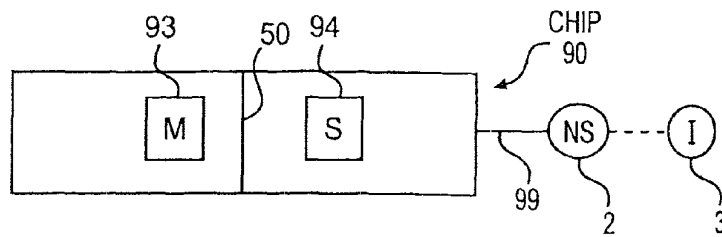


**FIG. 9B**

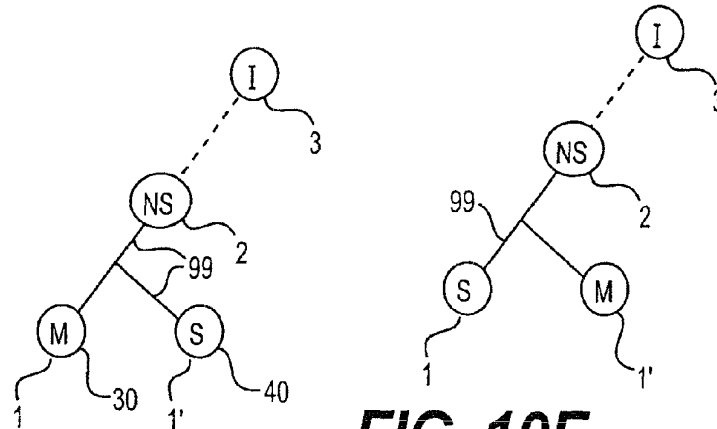


**FIG. 9C**



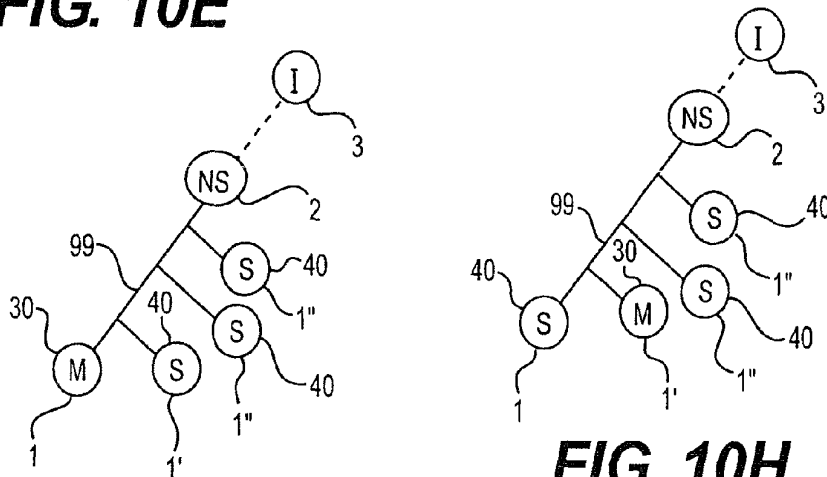


**FIG. 10D**



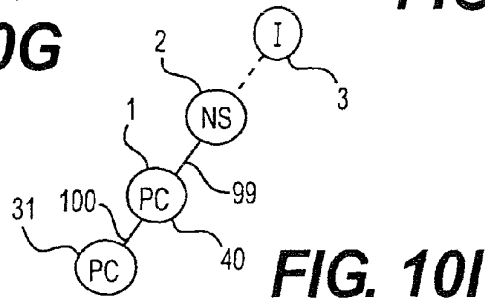
**FIG. 10E**

**FIG. 10F**

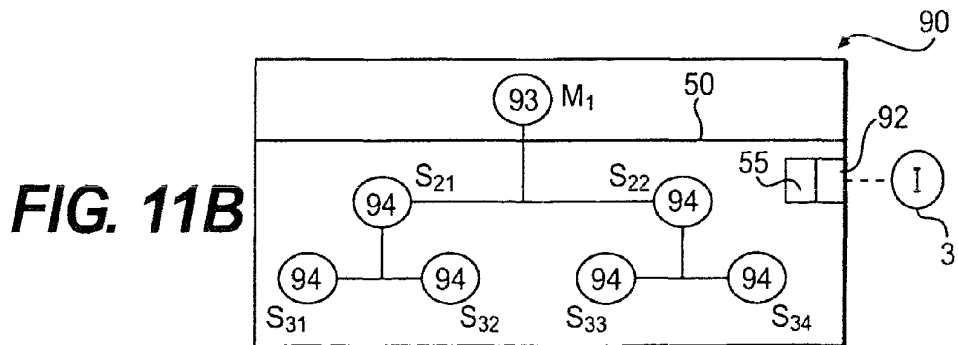
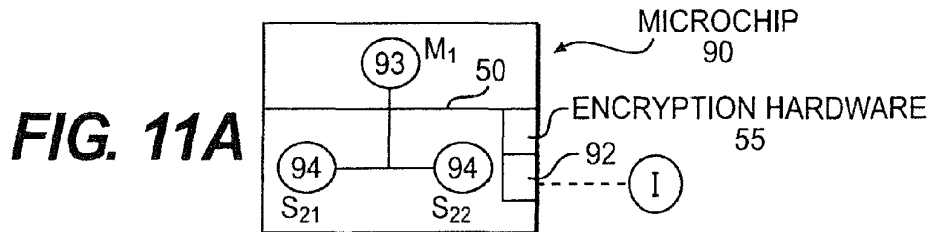
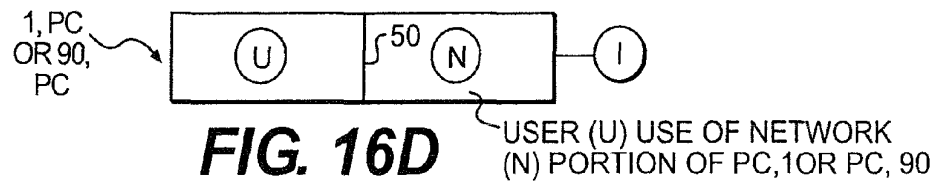
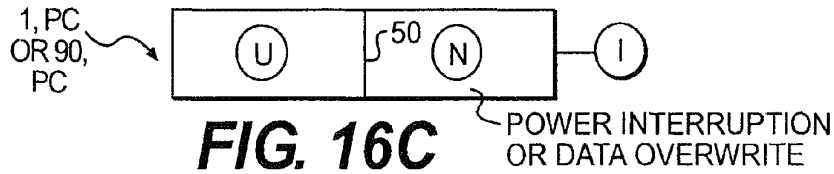
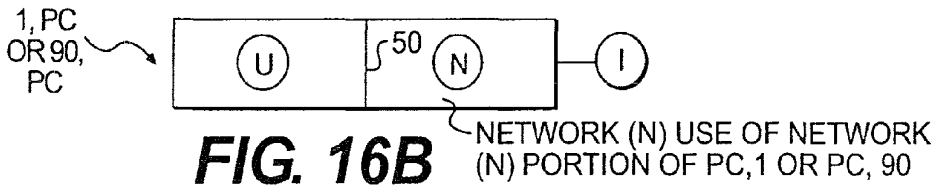
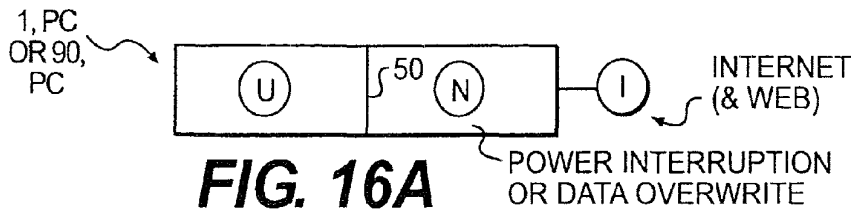


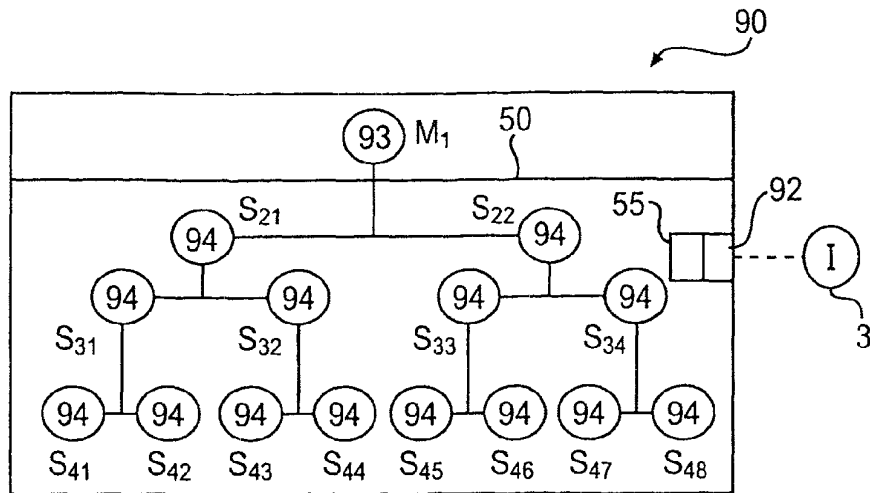
**FIG. 10G**

**FIG. 10H**

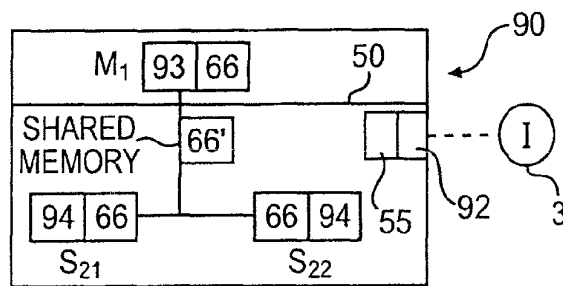


**FIG. 10I**

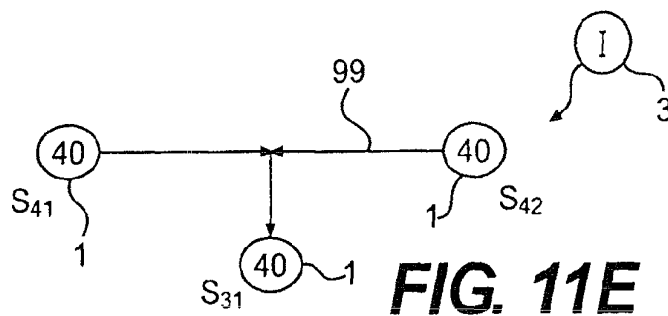




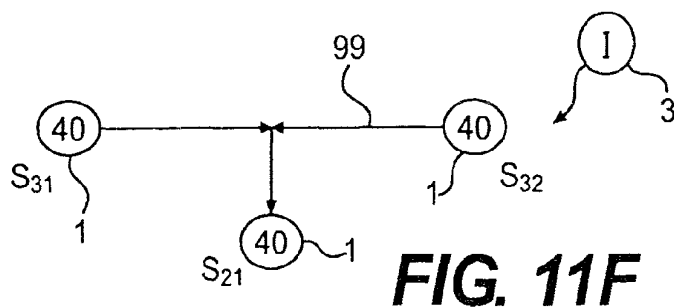
**FIG. 11C**



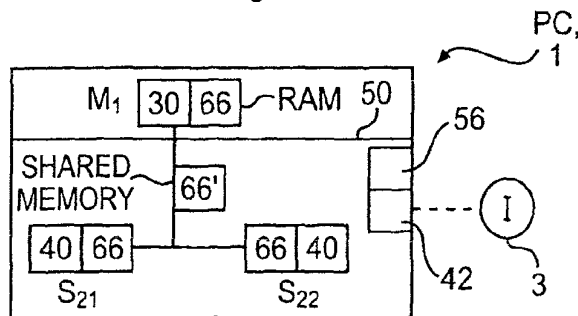
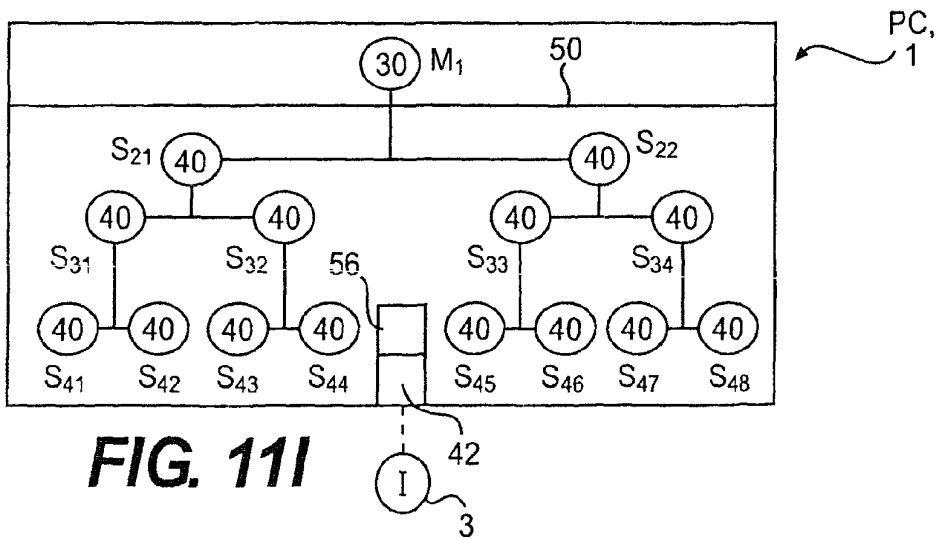
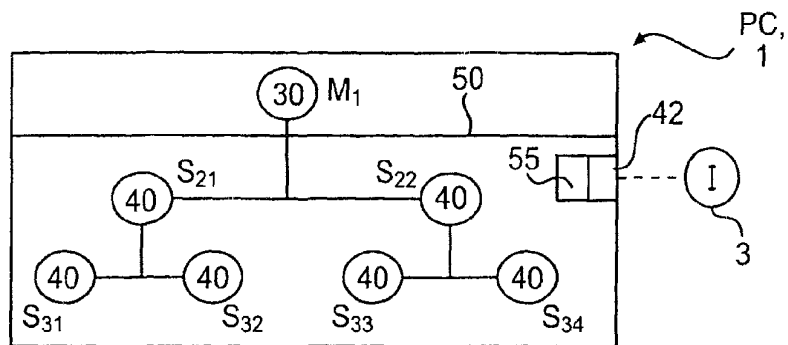
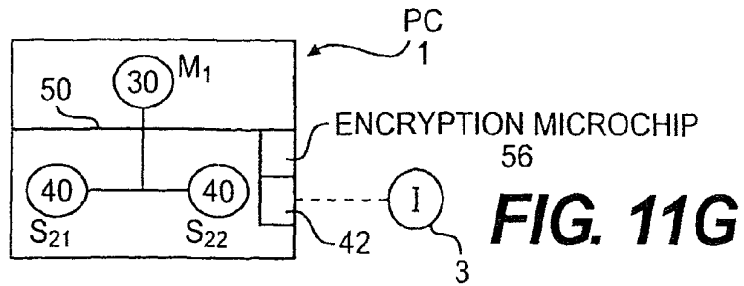
**FIG. 11D**

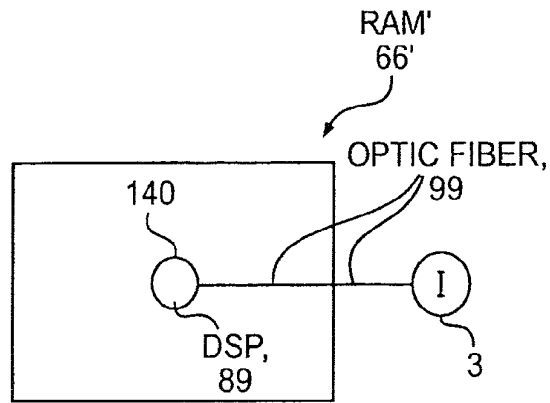


**FIG. 11E**

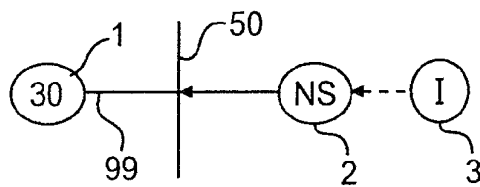


**FIG. 11F**

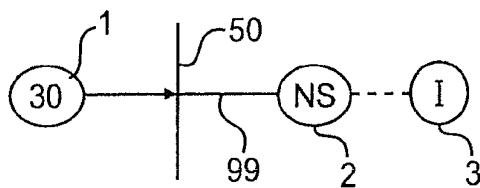




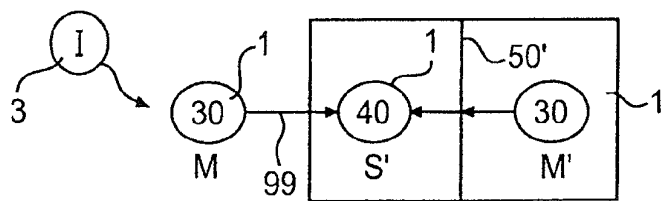
**FIG. 11K**



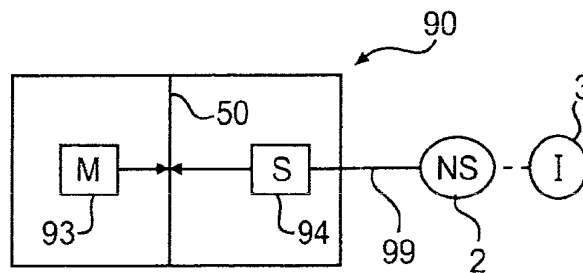
**FIG. 12A**



**FIG. 12B**



**FIG. 12C**



**FIG. 12D**

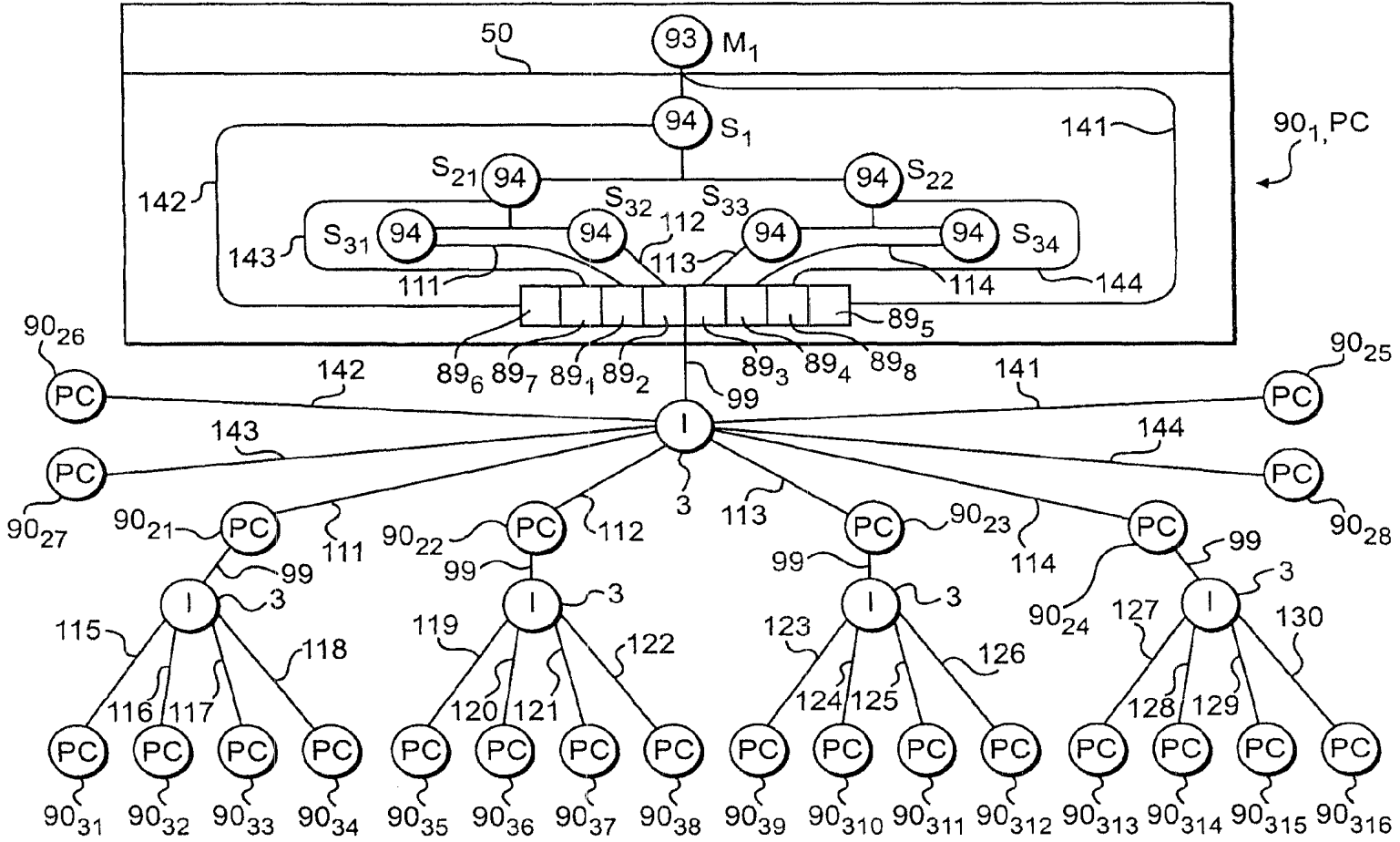
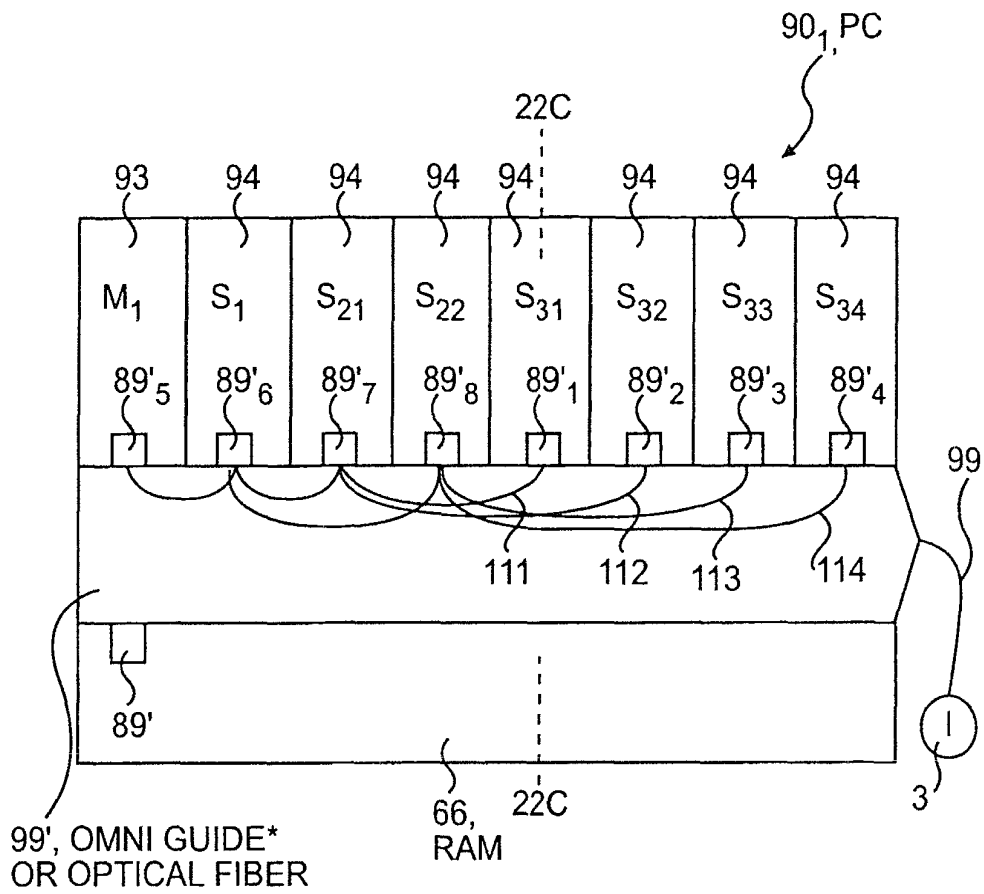
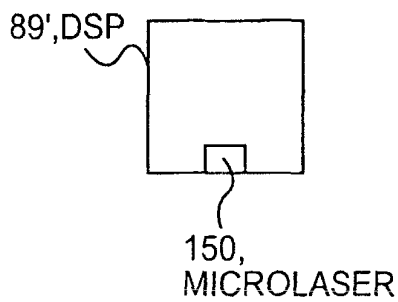


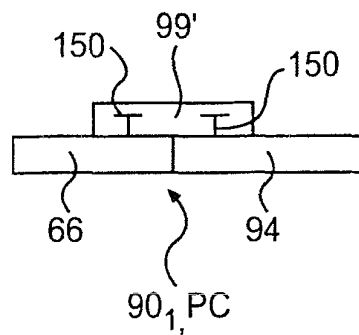
FIG. 13



**FIG. 14A**

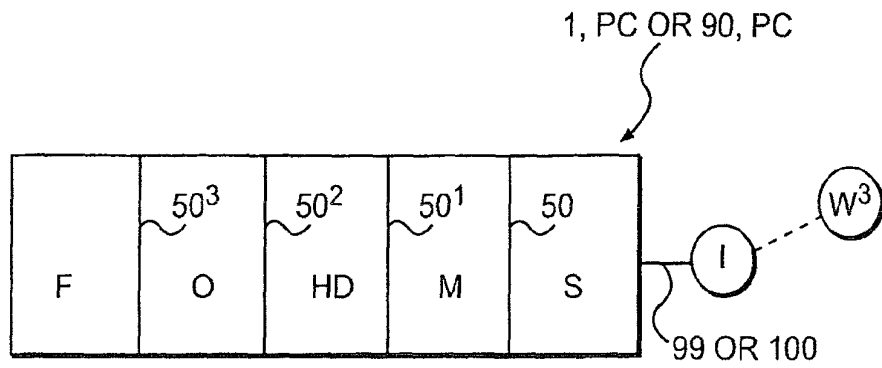


**FIG. 14B**

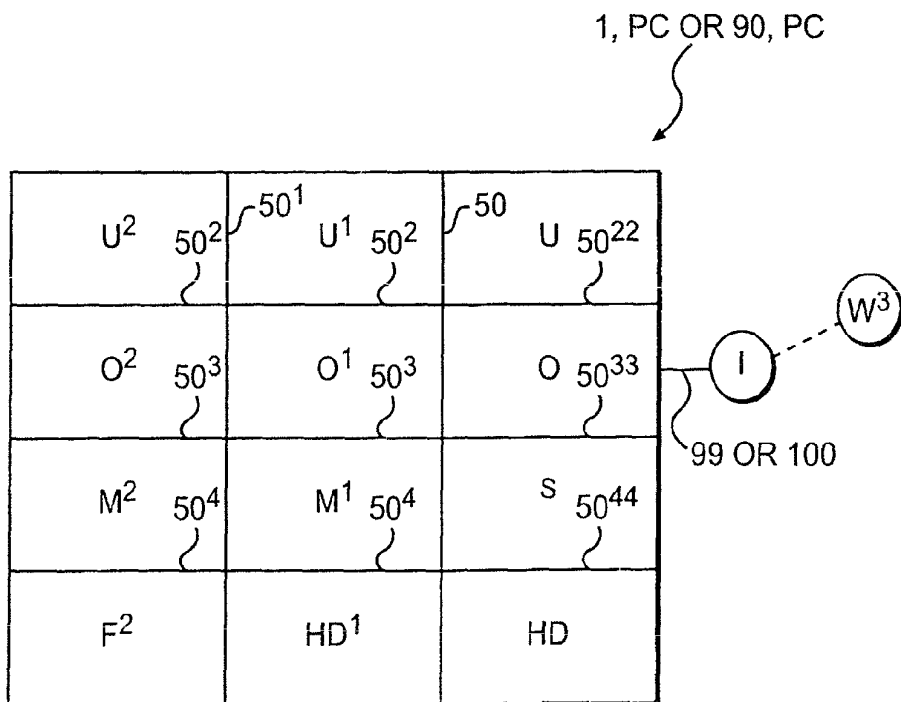


**FIG. 14C**

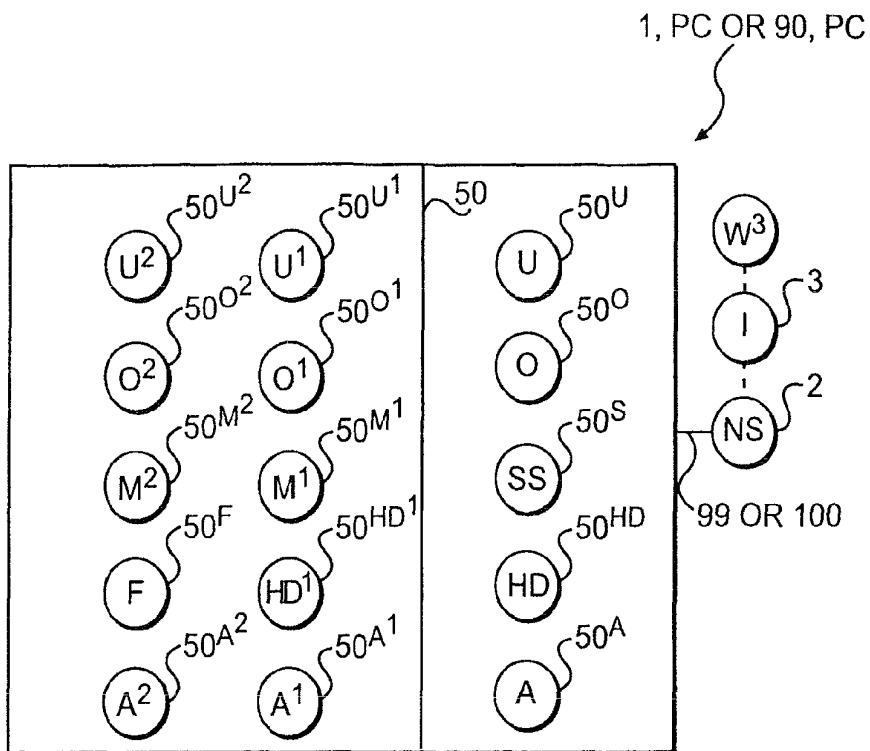




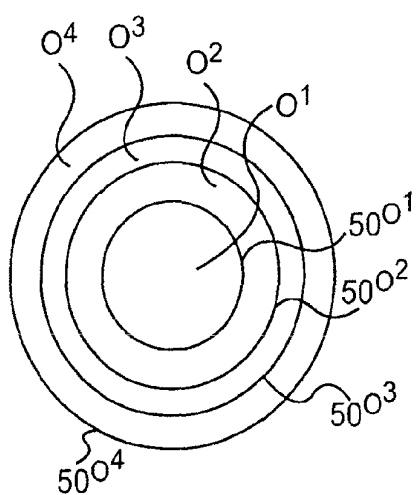
**FIG. 15A**



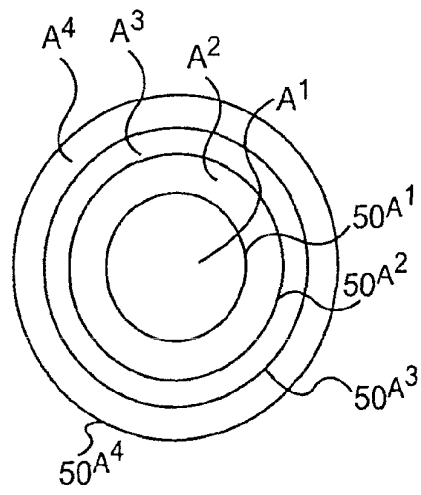
**FIG. 15B**



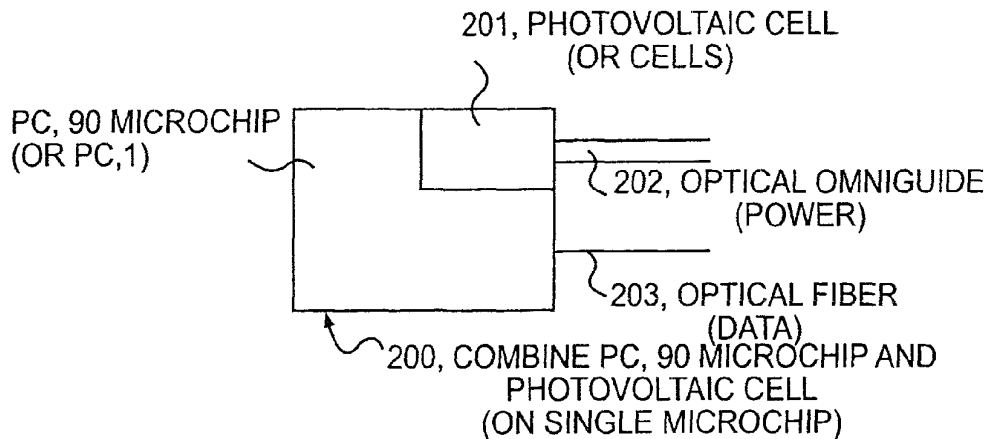
**FIG. 15C**



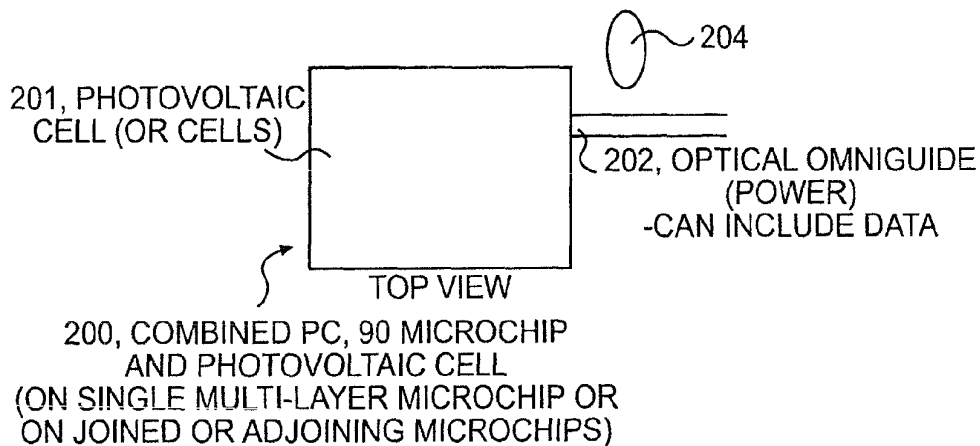
**FIG. 15D**



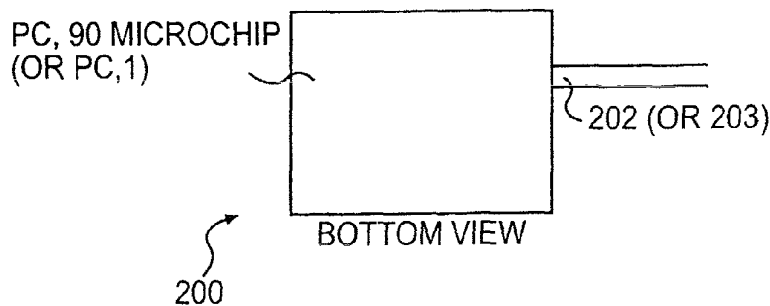
**FIG. 15E**



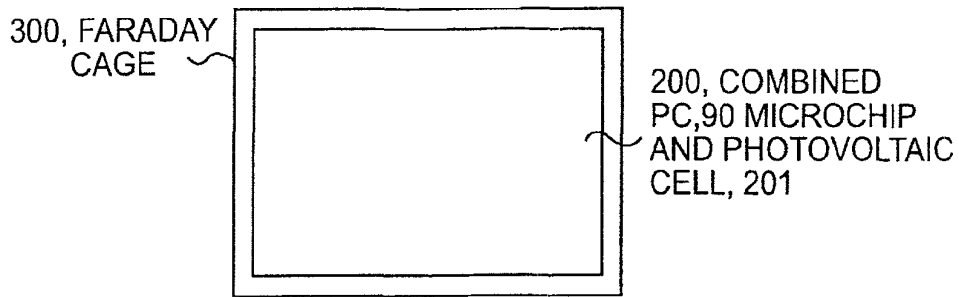
**FIG. 17A**



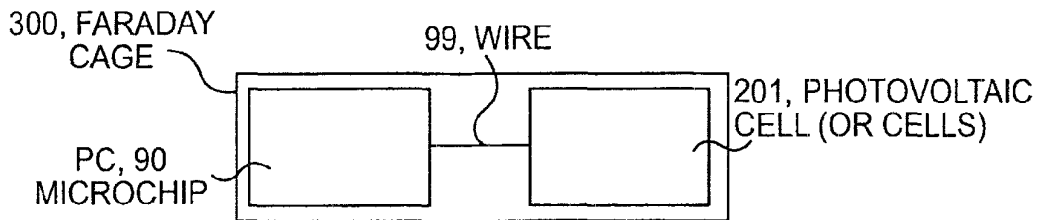
**FIG. 17B**



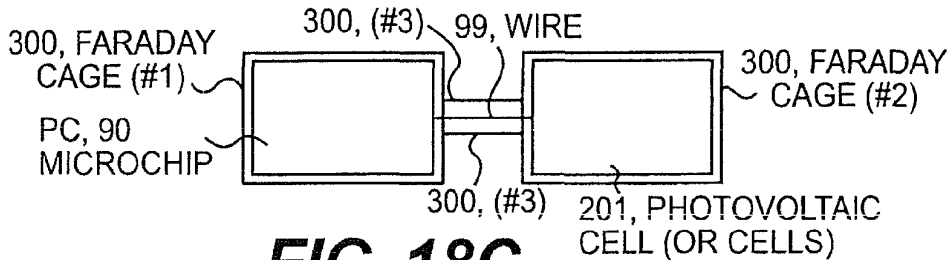
**FIG. 17C**



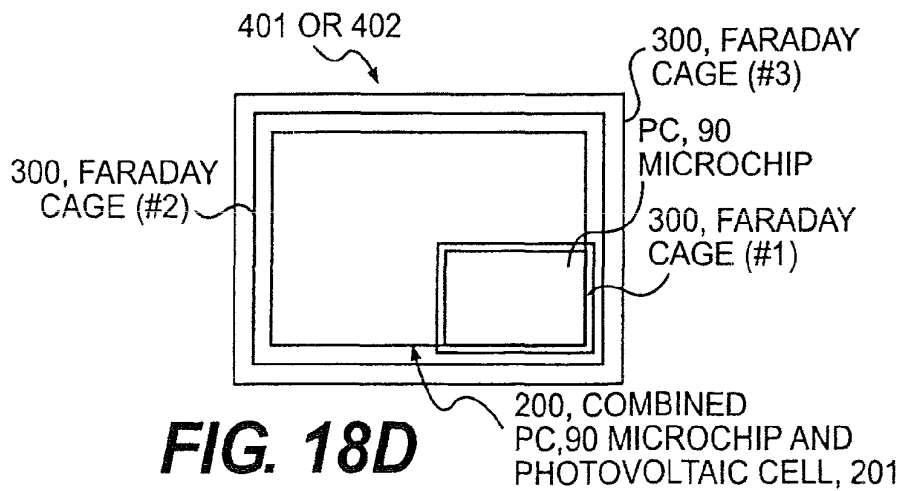
**FIG. 18A**



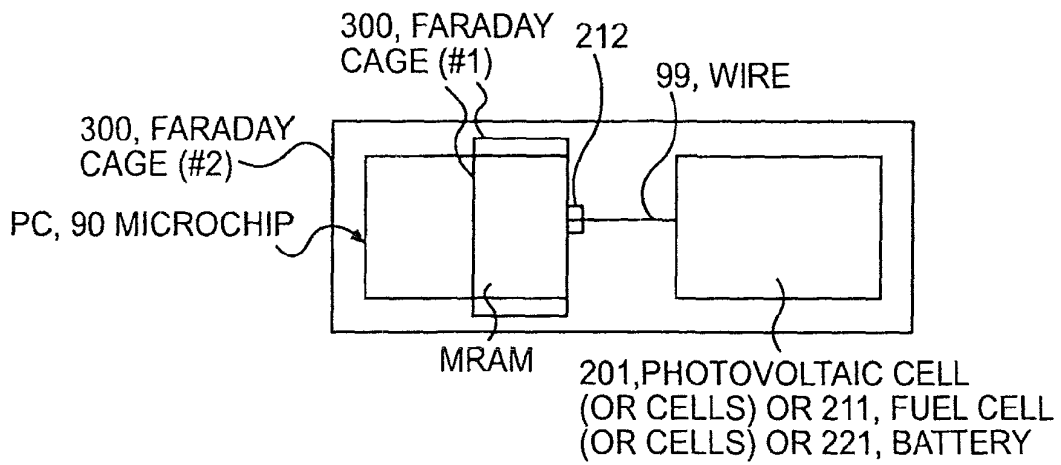
**FIG. 18B**



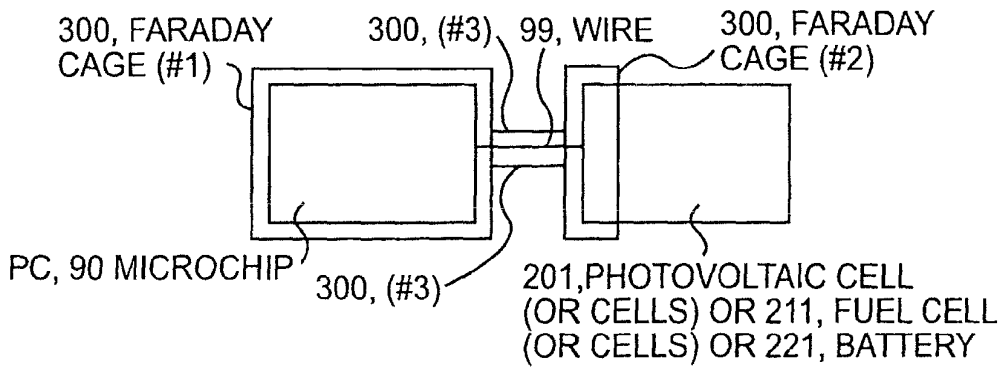
**FIG. 18C**



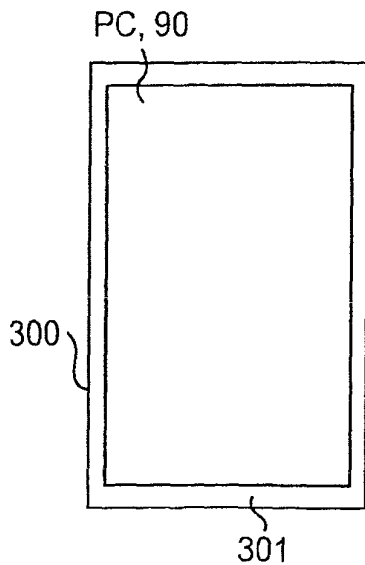
**FIG. 18D**



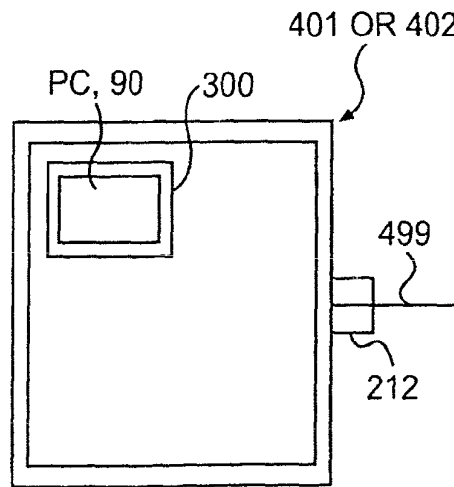
**FIG. 18E**



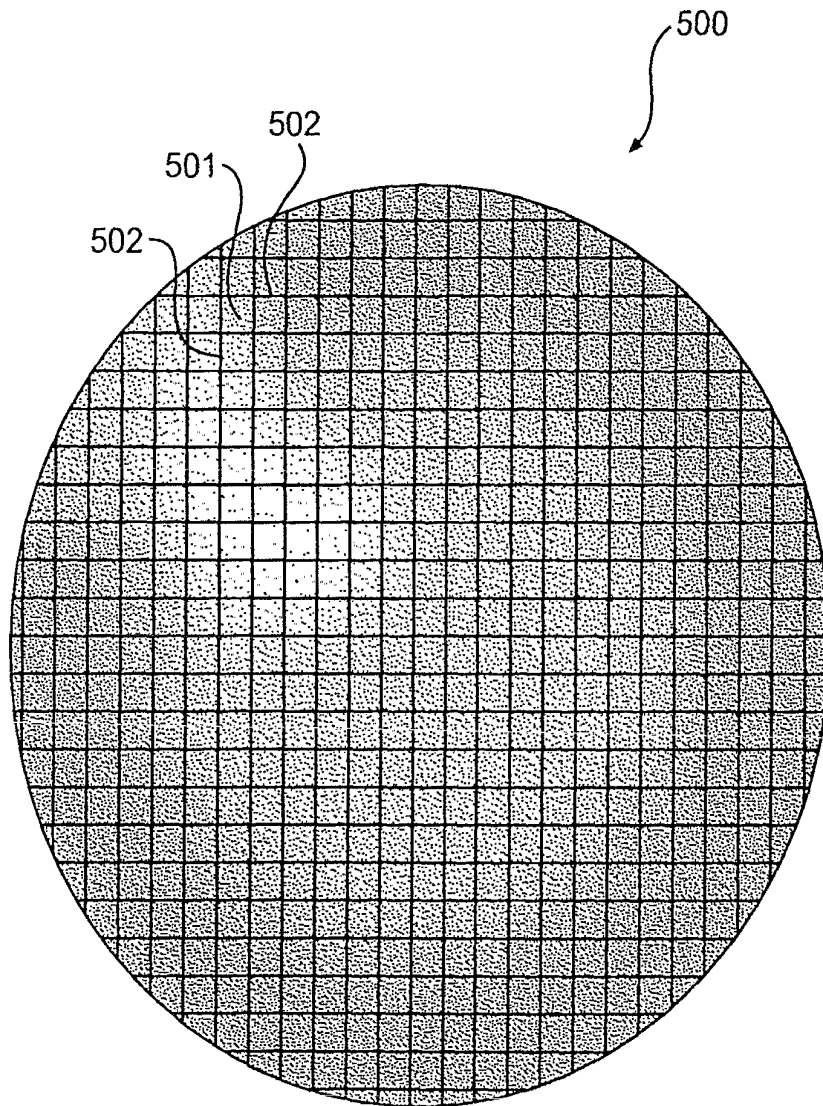
**FIG. 18F**



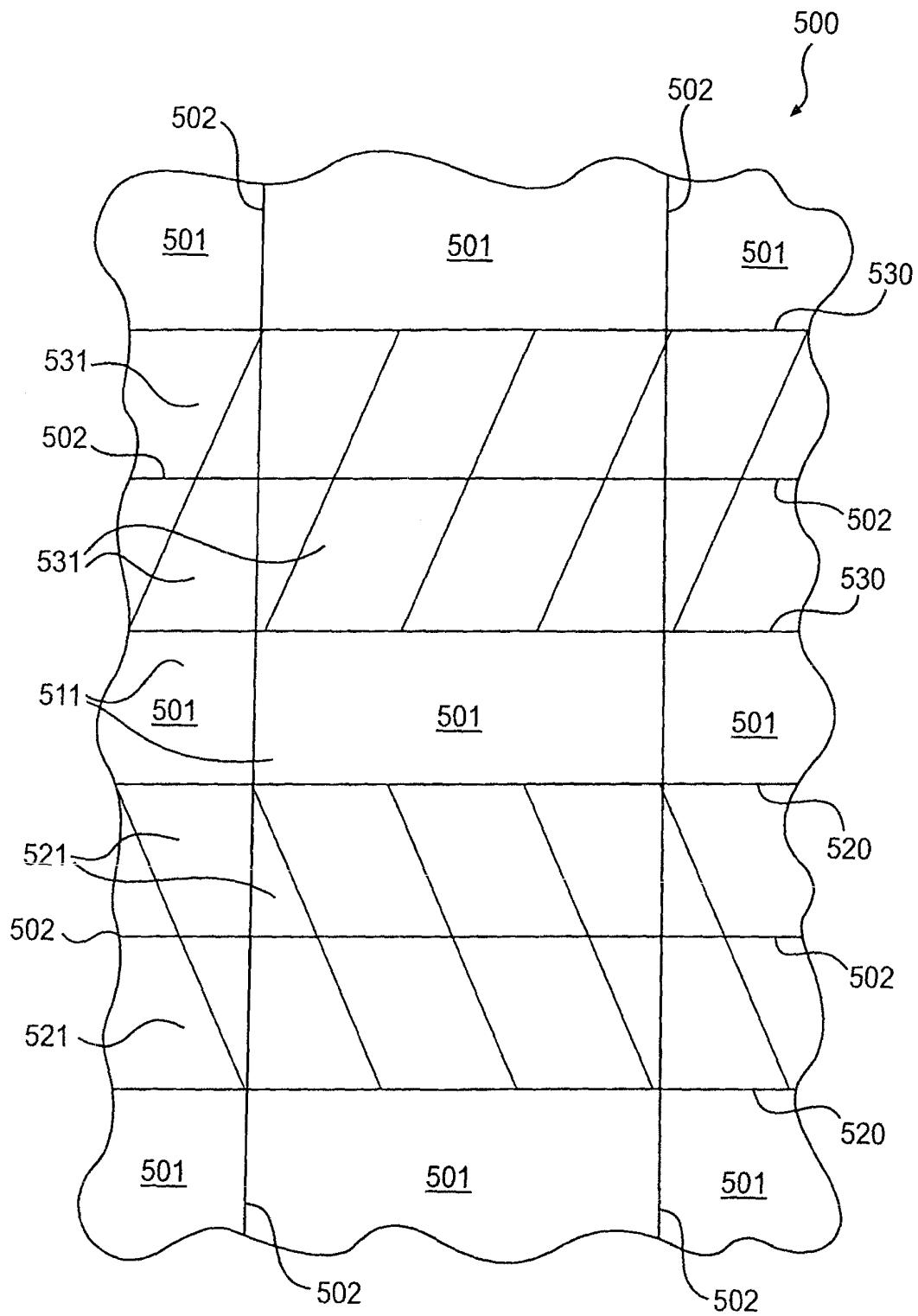
**FIG. 18G**



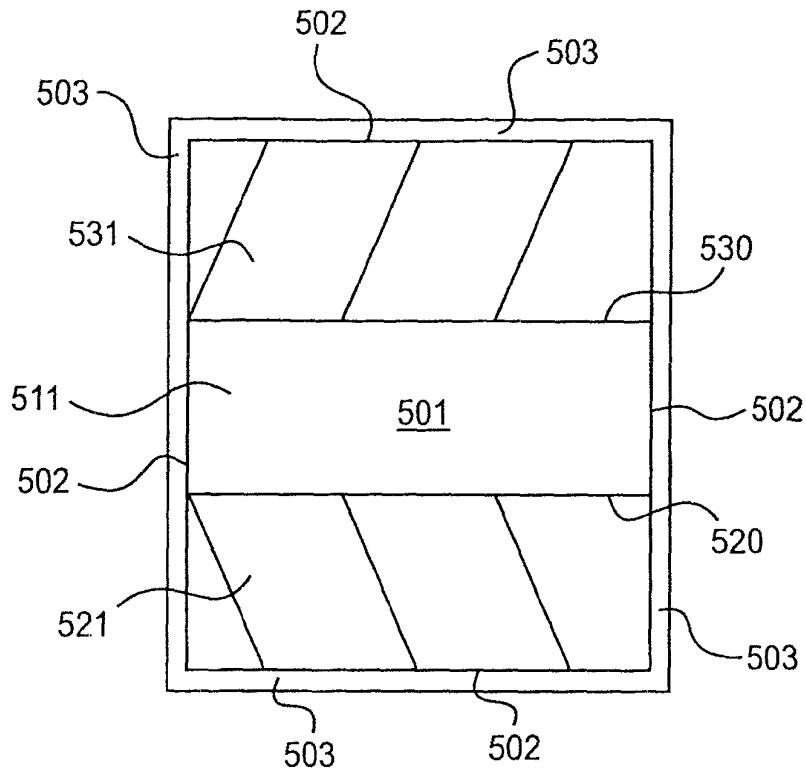
**FIG. 18H**



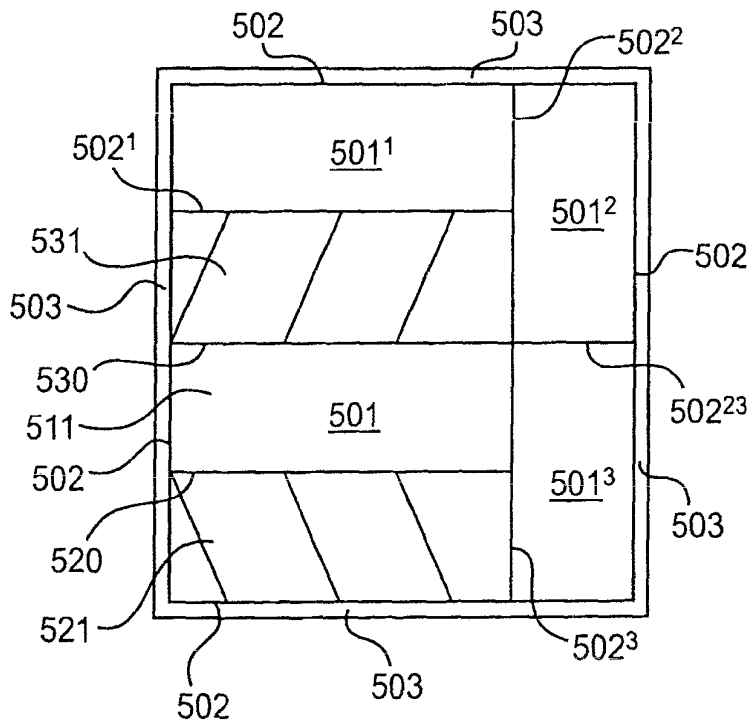
**FIG. 19**



**FIG. 20A**

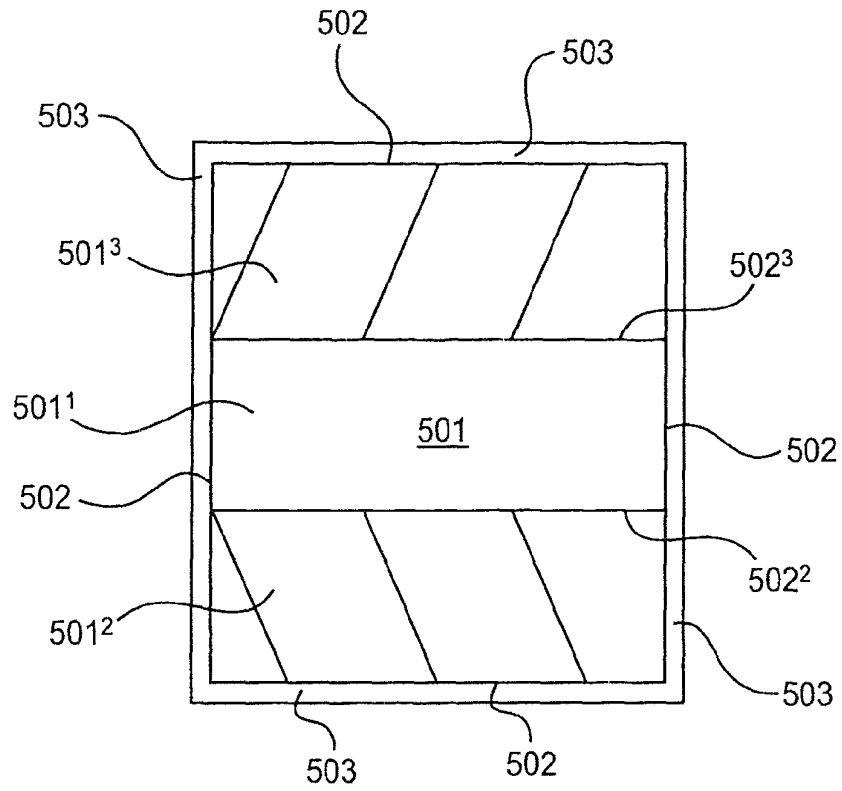


**FIG. 20B**

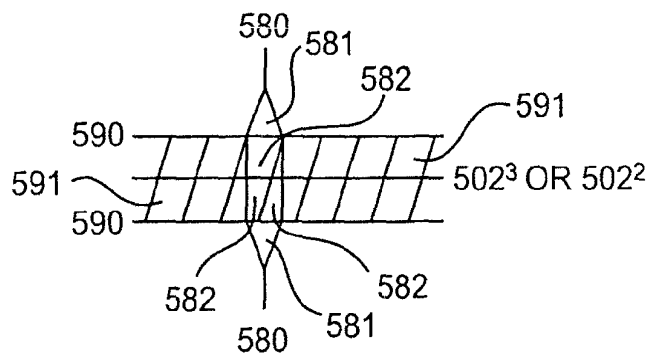


**FIG. 22**





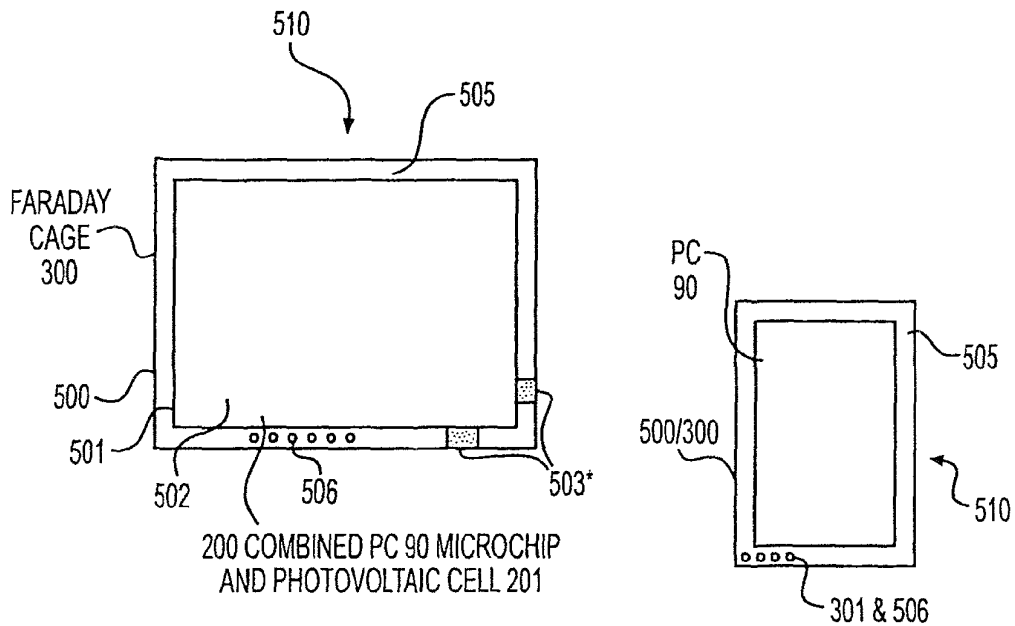
**FIG. 21A**



**FIG. 21B**

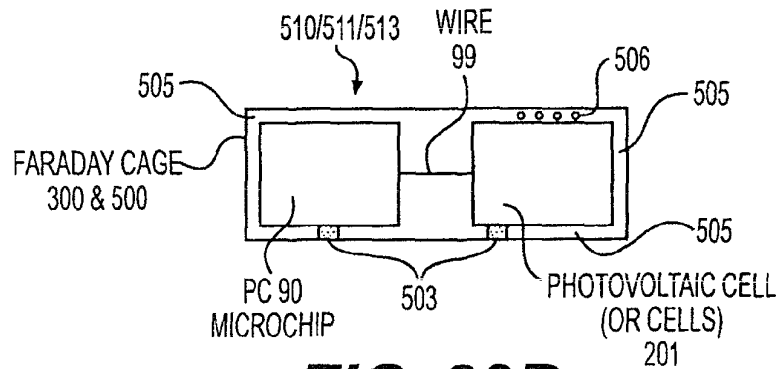


**FIG. 21C**

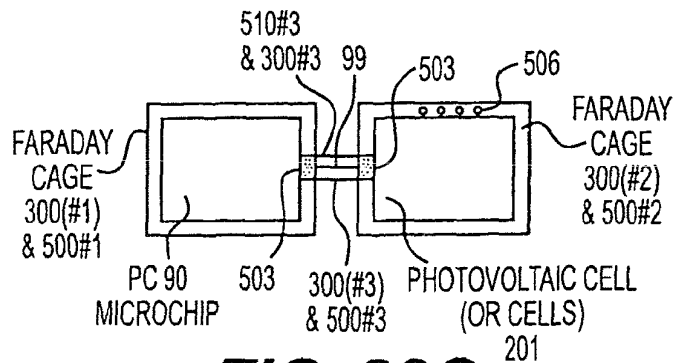


**FIG. 23A**

**FIG. 23G**

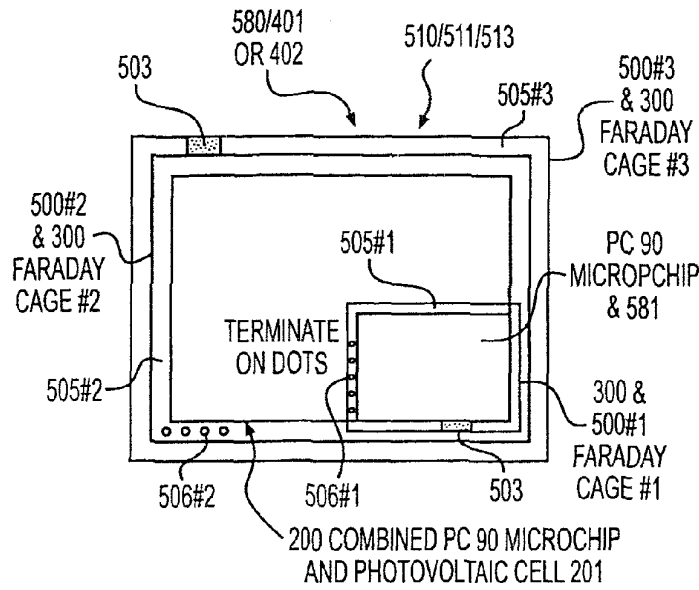


**FIG. 23B**

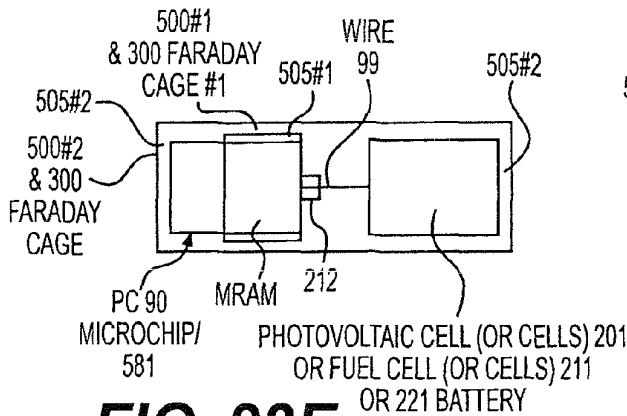


**FIG. 23C**

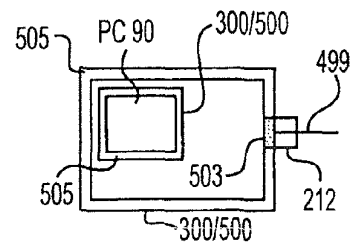
\*CAN INCLUDE EXTERNAL CONNECTION FROM MICROCHIP/CELL 200



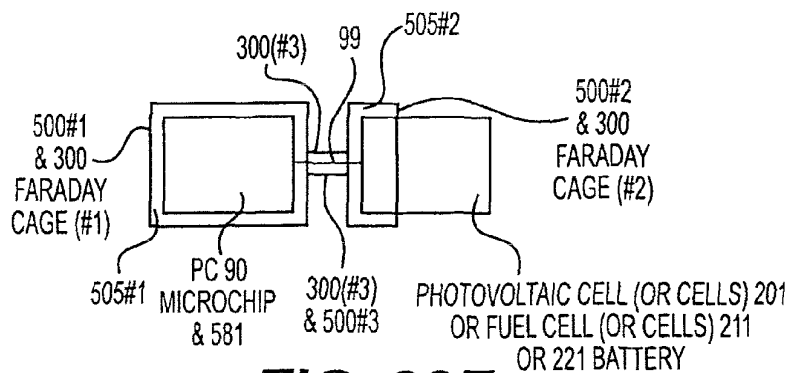
**FIG. 23D**



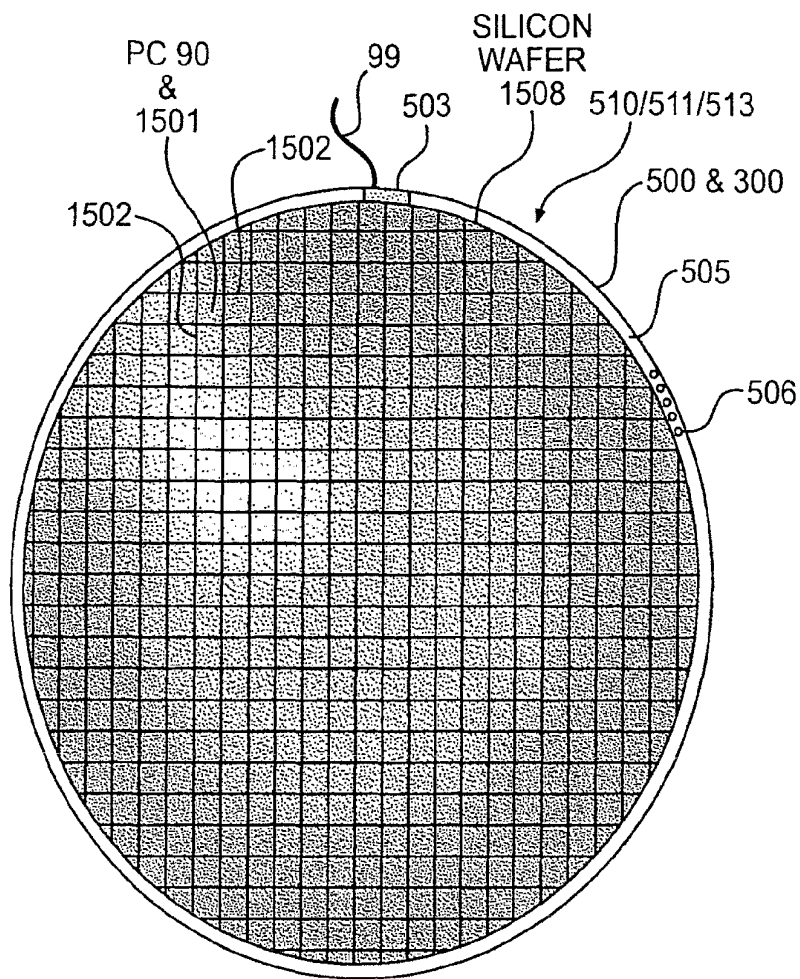
**FIG. 23E**



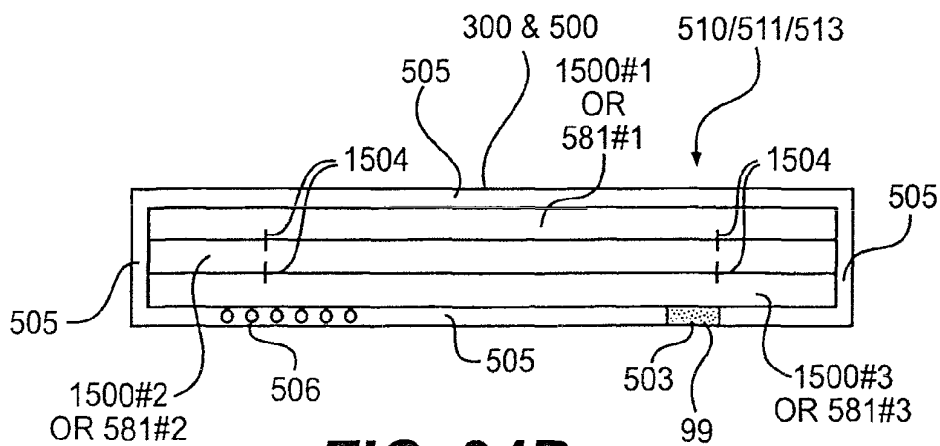
**FIG. 23H**



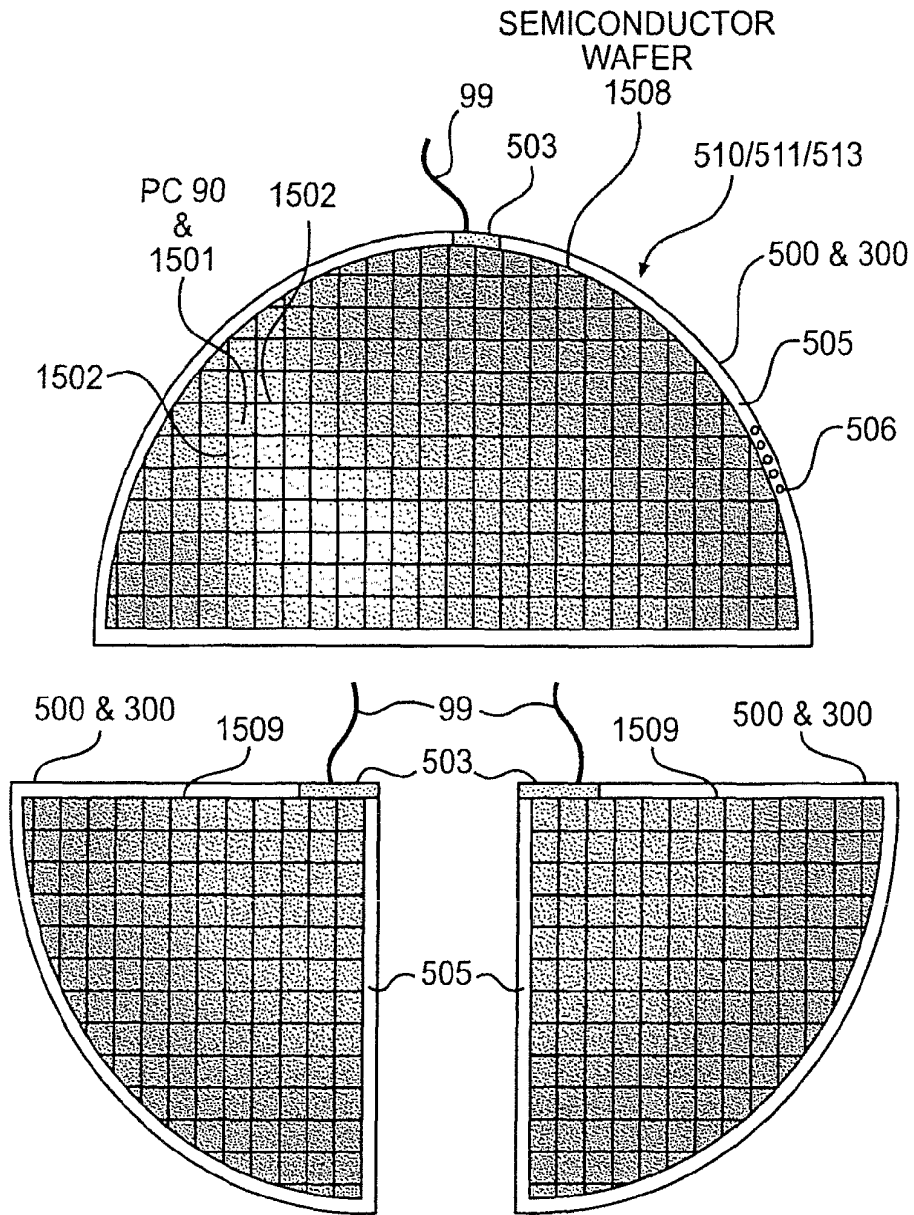
**FIG. 23F**



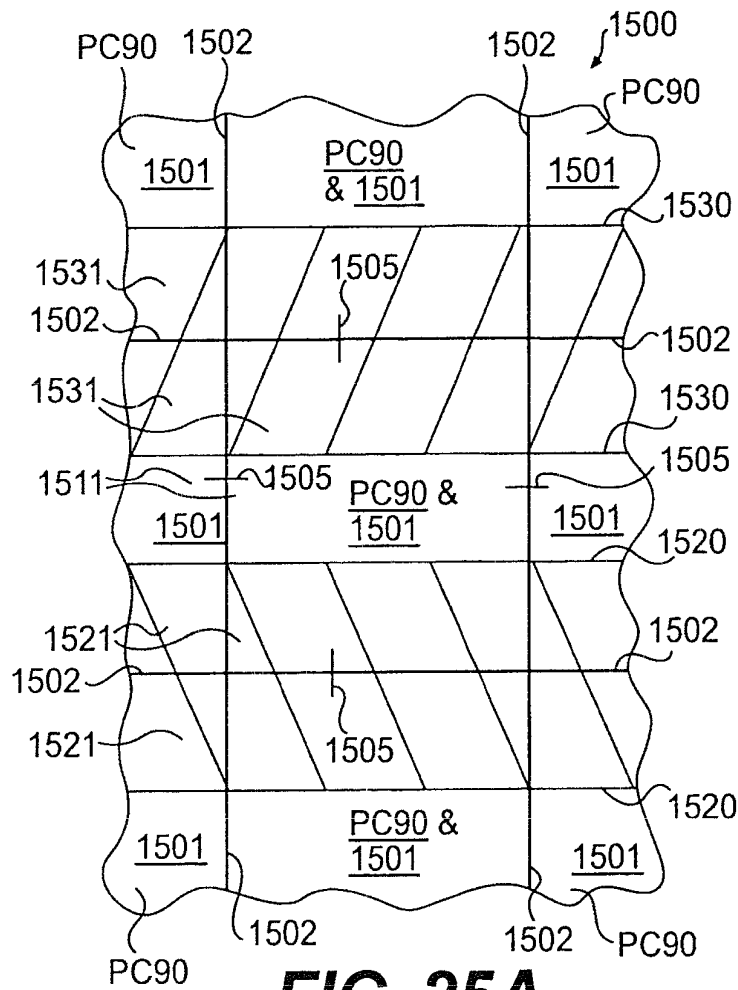
**FIG. 24A**



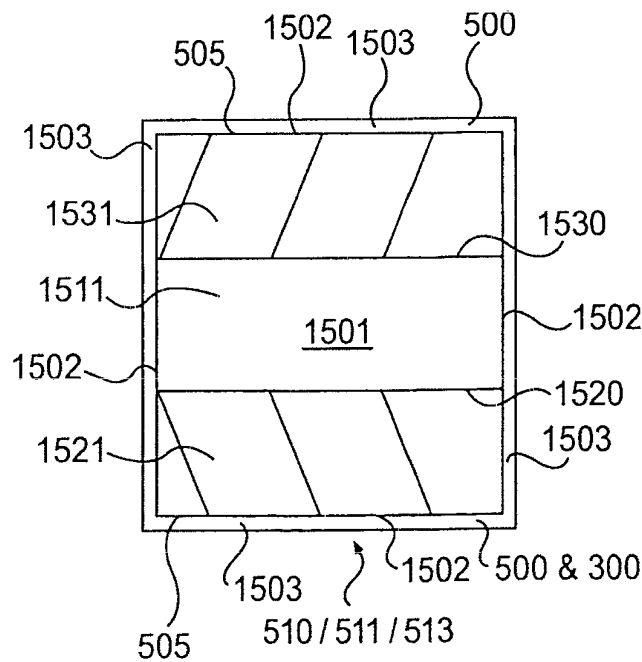
**FIG. 24B**



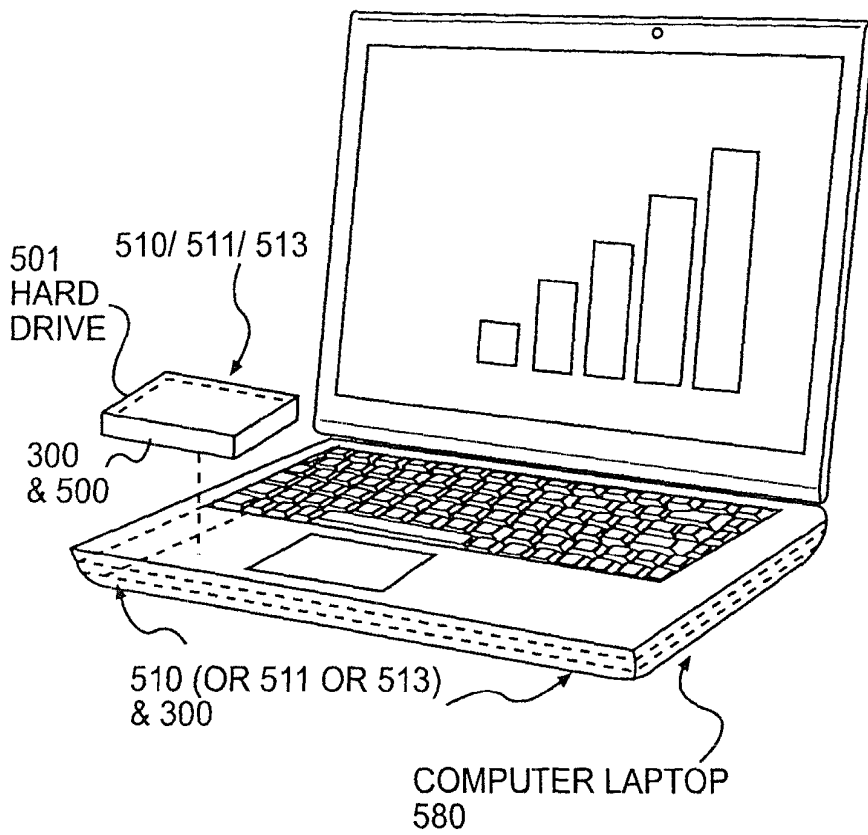
**FIG. 24C**



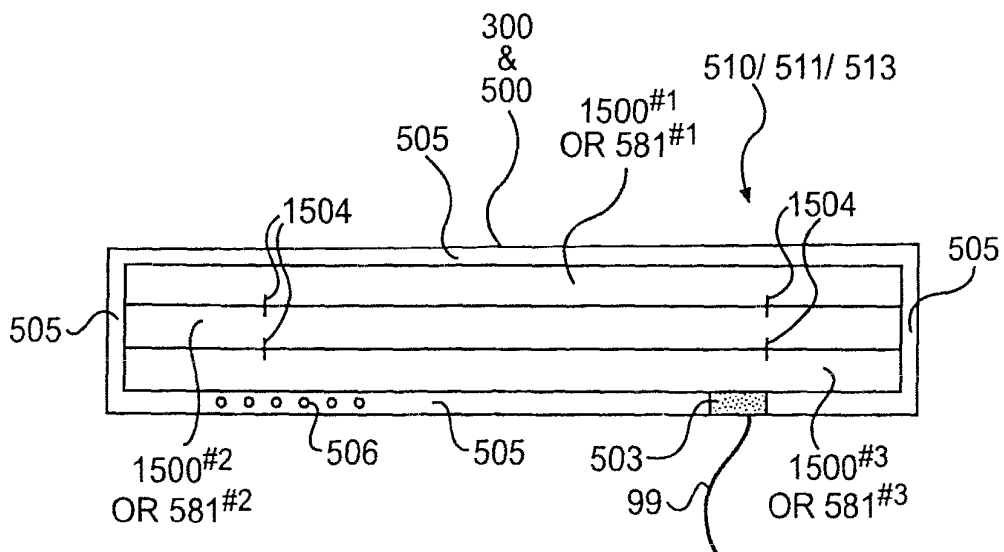
**FIG. 25A**



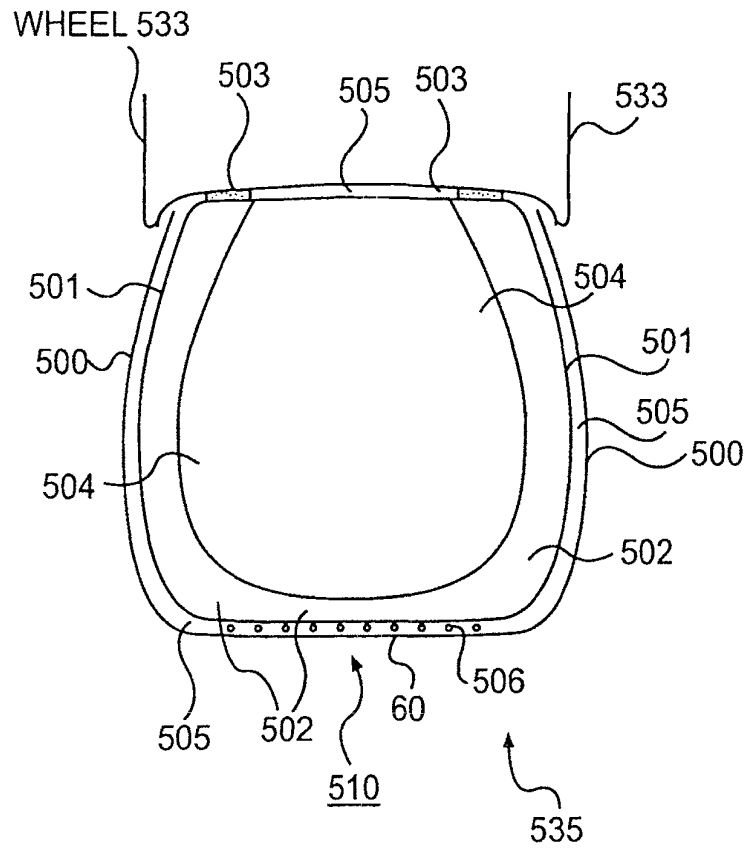
**FIG. 25B**



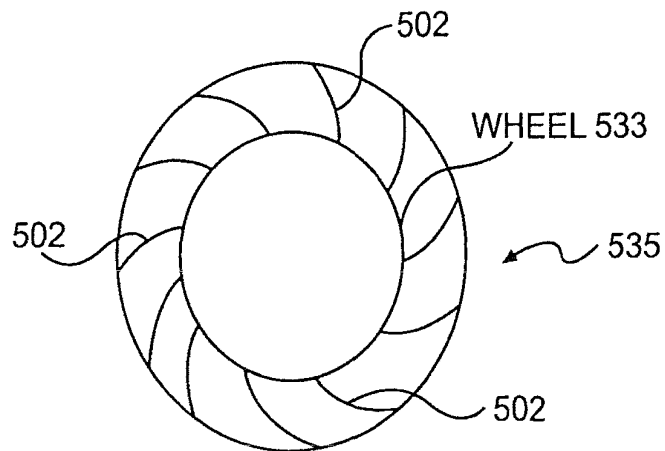
**FIG. 26A**



**FIG. 26B**



**FIG. 27A**



**FIG. 27B**



## COMPUTERS INCLUDING AN UNDICED SEMICONDUCTOR WAFER WITH FARADAY CAGES AND INTERNAL FLEXIBILITY SIPEs

This application is a continuation of U.S. patent application Ser. No. 12/292,769, filed Nov. 25, 2008, which is a continuation-in-part of U.S. patent application Ser. No. 12/292,553, filed Nov. 20, 2008, which is a non-provisional of U.S. Provisional Application No. 60/996,530, filed on Nov. 21, 2007, and U.S. Provisional Application No. 60/996,553, filed on Nov. 26, 2007. U.S. patent application Ser. No. 12/292,769, filed Nov. 25, 2008, is also a non-provisional of U.S. Provisional Application No. 60/996,553, filed on Nov. 26, 2007. The contents of all of the above-mentioned applications are hereby incorporated herein by reference.

### BACKGROUND

#### 1. Field of the Disclosure

The disclosure relates to a Faraday Cage surrounding semiconductor microchips, photovoltaic cells, and/or other micro and/or nano devices combined with the applicant's prior internal sipe inventions, including at least one compartment surrounded by at least one internal sipe, such as a slit. More specifically, a Faraday Cage coincides with an outer compartment, which forms one surface of a sipe surrounding an inner compartment including a personal computer microchip and/or a photovoltaic cell and/or a fuel cell and/or a battery.

The disclosure also relates to a semiconductor wafer, such as silicon, containing a multitude of microchips, such as with one or more core microprocessors. Instead of separating the microchips into separate dies in the conventional process, the entire semiconductor wafer is used essentially intact as a computer. More specifically, interconnects can be added to the printed circuit architecture of the wafer to connect the wafer microchips to other wafer microchips and/or other components on the wafer or external to it. Still more specifically, each microchip can be a complete system on a chip (SoC). Even more specifically, the semiconductor wafer can be used with other conventional interface devices for power and data, including wireless such as radio and/or optic, and/or wired such as fiber optic and/or electric, including for each SoC microchip on the wafer. In another specific embodiment, two or more semiconductor wafers can be stacked in vertical layers; for example, with a first wafer including microprocessors or cores; a second wafer including random access memory or RAM; and a third wafer including other components; each SoC microchip, in this example, can have one or more components on each of the three wafers.

The disclosure also relates to the semiconductor wafer including one or more of the applicant's prior internal sipe inventions, with an outer compartment having an internal sipe.

The disclosure also relates to the semiconductor wafer being surrounded by one or more Faraday Cages integrated into the internal sipe invention.

#### 2. Brief Description of the Prior Art

Faraday Cage surrounding semiconductor microchips, photovoltaic cells, and/or other micro and/or nano devices, are described by the applicant in his U.S. application Ser. No. 10/802,049 filed Mar. 17, 2004, and published as Pub. No. US 2004/0215931 A1 on Oct. 28, 2004.

The applicant's prior internal footwear sipe inventions, including at least one compartment surrounded by at least one internal sipe, such as a slit, are described by the applicant in his U.S. patent application Ser. No. 11/802,930, filed May 25,

2007 and published as Pub. No. US 2008/0086916 A1 on Apr. 17, 2008, as well as in several earlier U.S. applications filed by the applicant.

Existing semiconductor wafers, currently up to 300 mm in diameter, are always cut into a large number of separate dies, with one microchip formed into a package from each flaw-free die cut from the semiconductor wafer; some dies are inherently defective and are discarded. A typical semiconductor wafer is shown in the applicant's U.S. application Ser. No. 10/684,657 filed Oct. 15, 2003.

As described in Wikipedia, "wafer scale integration" (WSI) is a yet-unused system of building very-large integrated circuit networks that use an entire silicon wafer to produce a single "super-chip." Through a combination of large size and reduced packaging, WSI could lead to dramatically reduced costs for some systems, notably massively parallel supercomputers.

Many companies including TI and ITT attempted to develop "wafer scale integration" (WSI) production systems in the 1970's and '80's, but all failed and no products were released. Further attempts at WSI appear to be largely abandoned for decades.

One critical problem that has not been overcome is that of inherent flaws in semiconductor wafers. It has been an ongoing goal to develop methods to handle faulty areas of the wafers through logic, as opposed to sawing them out of the wafer. Generally, this approach uses a grid pattern of sub-circuits and "rewires" around the damaged areas using appropriate logic.

The overwhelming difficulty of this approach is illustrated by the history of famous computer pioneer Gene Amdahl, who attempted to develop WSI as a method of making a supercomputer, starting Trilogy Systems in 1980 and garnering investments from Groupe Bull, Sperry Rand, and Digital Equipment Corporation, who (along with others) provided as estimated \$230 million in financing. The design called for a 2.5" square chip with 1200 pins on the bottom. After burning through about one third of the capital with nothing to show for it, Amdahl eventually declared the idea would only work with a 99.99% yield, which would not happen for 100 years. There were several subsequent efforts in the 1980's, but none successful.

Another well-known problem is the field of wafer-scale integration technology is the impact of thermal expansion on external connectivity. More specifically, when a WSI micro-electronic complex is connected to a circuit board by thousands of, for example, connectors positioned between the microelectronic complex and the circuit board, these connectors can be damaged due to the different rates of thermal expansion experience by the surfaces of the microelectronic complex and circuit board.

Taking for example a finished silicon wafer, packaged in a material such as ceramic, the wafer typically expands at a rate of 3 ppm/C. In contrast, the material of the circuit board typically expands at a rate of 20-40 ppm/C. Thus, as the two materials heat up, the two surfaces will expand at different rates, potentially damaging many of the connectors distributed between the wafer and the circuit board. See Norman, et al., U.S. Pat. No. 7,279,787.

The present disclosure solves these longstanding problems with existing technology.

### SUMMARY

In the applicant's disclosure regarding Faraday Cages and siped compartments, two entirely different technologies (siped cushioning compartments and Faraday Cages) from

two entirely different and unrelated fields of technology (“macro” athletic footwear and microelectronics), each with their own completely different art, have been integrated into a surprising new combination wherein the integrated structural components have simultaneous dual functions that are completely separate and unrelated.

Moreover, the integrated use of a sipe media both as a lubricant between the siped compartments and as a cooling media for a microchip (or other electronic component) to deal with the critical microprocessor heat dissipation problem is an additional surprising combination of two entirely separate technical functions that are completely different into a single new structural and material component with dual functions, again from entirely different and unrelated fields of art.

The applicant’s semiconductor wafer computer disclosure solves the two longstanding problems that have heretofore made all such wafer-scale integration efforts fail.

First, the applicant’s disclosure solves the longstanding inherent flaw intolerance problem discussed above by using microchips on the wafer that are personal computer systems on the chip (SoC), so that each wafer microchip can operate independently, including communicating with other wafer microchips, such as wirelessly in free space and/or waveguides by radio or optical device. In the applicant’s approach, the wafer microchips that inherently are flawed during manufacture or fail in operation require no elaborate special handling like that described above. Generally, if they fail fatally, the remaining wafer microchips inherently ignore them since they do not communicate with other microchips; also, partial failure can be detected remotely and the microchip can be turned off, if necessary.

Second, the applicant’s disclosure solves the longstanding unequal thermal expansion problem discussed above by reducing, even almost eliminating the need for pins, since both on wafer and off wafer communication by the independently functioning microchips (personal computer SoC’s) on the wafer can be accomplished by radio or optics connections that do not require pins or require far fewer structural connections. In addition, the applicant’s use of stacked semiconductor wafers, which can have very similar or identical materials and expansion rates, can obviate the need for conventional motherboards or reduce their role.

Moreover, since the personal computer microchips on the semiconductor wafer can operate independently, such as in conventional clusters of several or many or all of the personal computers on the wafer (or including personal computers off the wafer as well), the operations occurring on the wafer can be asynchronous. The applicant’s disclosure thereby also solves the longstanding problem of synchronizing such wafer scale operations by obviating the need for synchronizing them, as would be necessary without the applicant’s disclosure.

These and other features of the disclosure will become apparent from the detailed description that follows.

#### BRIEF DESCRIPTION OF THE DRAWINGS

FIGS. 1-9 of this application are FIGS. 1-6, 52, 61, 67, 74, and 79 of both the applicant’s U.S. application Ser. No. 11/802,033 filed May 18, 2007 and published on Apr. 10, 2008 as Pub. No. US 2008/0083140 A1 and PCT Application PCT/US2007/011976 filed 18 May 2007 and published on 31 Jan. 2008 as Int. Pub. No. WO 2008/013594 A2, as well as U.S. application Ser. No. 11/802,930 filed May 25, 2007 and published on Apr. 17, 2008 as Pub. No. US 2008/0086916 A1; all three applications are incorporated herein by reference. In addition, FIGS. 1-6 (except 6D-6F) of this application are

FIGS. 83-88 of both the applicant’s U.S. application Ser. No. 11/282,665 filed Nov. 21, 2005 and published on Nov. 9, 2006 as Pub. No. US 2006/0248749 A1 and PCT Application PCT/US2005/042341 filed 21 Nov. 2005 and published on 1 Jun. 2006 as Int. Pub. No. WO 2006/058013 A2, both of which are incorporated herein by reference.

FIG. 1A-4A show a frontal or sagittal plane cross section view of an example of a device 510 such as a flexible insert with a siped compartment or chamber or bladder.

FIGS. 1B-6B shows a horizontal plane view of a device 510 example.

FIG. 1C is an exploded perspective view showing the relationship of an insert device 510, which has a siped compartment or chamber or bladder, with a midsole, bottom sole, and upper of a shoe or other footwear.

FIGS. 1D-1F show an example of the 510 invention using typical commercial air bladder embodiments as compartment 501 modified with outer compartment 500.

FIGS. 5A-6A show a frontal or sagittal plane cross section view of an example of a device 510 such as a flexible insert with two siped compartments or chambers or bladders or combination.

FIG. 7A shows a computer laptop with the 510/511/513 inventions and FIG. 7B shows a semiconductor microchip with the 510/511/513 inventions.

FIGS. 7C-7D show additional examples of the 510/511/513 inventions applied to electronic game controllers and cell phone.

FIG. 8 is a chart showing approximate comparison of hardness scales.

FIGS. 9A-9C show a large urban telephone book lying flat, solid wooden block, and an upright very thick book to illustrate basic concepts of sipe flexibility and stability.

FIGS. 10-22 of this application are FIGS. 10A-10I, 16A-16Z, 16AA, and 16AB, 17A-17D, 21B, 22A, 23A-23E, 25A-25D, 26A-26C, 27A-27H, 28, 29A, 30A-30C, and 31 of both the applicant’s U.S. application Ser. No. 10/802,049 filed May 17, 2004 and published on Oct. 28, 2004 as Pub. No. US 2004/0215931 A1.

FIGS. 10A-10I are simplified diagrams of a section of a computer network, such as the Internet, showing an embodiment of a system architecture utilizing an internal firewall to separate that part of a networked PC (including a system reduced in size to a microchip) that is accessible to the network for shared processing from a part that is kept accessible only to the PC user; also showing the alternating role that each PC in the network may play as either a master or slave in a shared processing operation involving one or more slave PC’s in the network; and showing a home or business network system which can be configured as an Intranet; in addition, showing PC and PC microchips controlled by a controller (including remote) with limited or no processing capability; and showing PC and PC microchips in which an internal firewall 50 can be reconfigured by a PC user.

FIGS. 11A-11K show a new hierarchical network architecture for personal computers and/or microprocessors based on subdivision of parallel processing or multi-tasking operations through a number of levels down to a processing level.

FIGS. 12A-12D show an internal firewall 50 with a dual function, including that of protecting Internet users (and/or other network users sharing use) of one or more slave personal computers PC 1 or microprocessors 40 from unauthorized surveillance or intervention by an owner/operator of those slave processors.

FIG. 13 shows that all microprocessors of a personal computer or personal computer on a microchip can have a sepa-

rate input/output communication link to a digital signal processor (DSP) or other transmission/reception connection component.

FIG. 14 shows a PC microprocessor on a microchip similar to that of FIG. 13, except that Figure shows microprocessors **93** and **94** each connecting to an optical wired connection **99'** such as thin mirrored hollow wire or optical omniguide or optical fiber.

FIG. 15 show multiple firewalls **50** within a personal computer **1** or PC microchip **90**.

FIG. 16 show the use for security of power interruption or data overwrite of volatile memory like DRAM and non-volatile memory like Flash or MRAM (or ovonics), respectively, of the network portion of a personal computer PC1 or system on a microchip PC90.

FIG. 17 show exemplary microchip and photovoltaic cell embodiments.

FIG. 18 show exemplary microchip and Faraday Cage embodiments.

FIG. 19 shows a silicon wafer **500** used to make microchips.

FIG. 20A shows a top view of a microchip **501** surrounded by adjoining portions of adjoining microchips **501** in a section of the silicon wafer **500**. FIG. 20B shows a top view of the microchip **501** embodiment of FIG. 20A after the die has been separated from the silicon wafer **500** and positioned in a microchip package **503**.

FIG. 21 show alternative embodiments that unite separate fabrication processes on the same microchip **501**.

FIG. 22 shows a combination of the embodiments shown in FIGS. 20 and 21.

FIGS. 23A-23H are modifications of FIGS. 18A-27H of this application, which are FIGS. 27A-27H of U.S. application Ser. No. 10/802,049 filed Mar. 17, 2004 and published on Oct. 28, 2004, as Pub. No. US 2004/0215931 A1 and U.S. application Ser. No. 10/684,657 filed Oct. 15, 2003 and published on Aug. 18, 2005, as Pub. No. US 2005/0180095 A1, both of which applications are hereby incorporated by reference herein for completeness of disclosure.

FIGS. 23A-23H are more specific example embodiments of the FIG. 7B example; they show examples of the applicant's inventions involving one or more Faraday Cages surrounding various combinations of semiconductor microchips, photovoltaic cells, and/or other micro and/or nano devices with the applicant's internal sipe inventions **510/511/513**.

FIGS. 24A and 25A-25B are modifications of FIGS. 28 and 29A-29B of U.S. application Ser. No. 10/684,657 filed Oct. 15, 2003 and published on Aug. 18, 2005, as Pub. No. US 2005/0180095 A1, which was above incorporated by reference herein for completeness of disclosure.

FIG. 24A is a top view of a semiconductor wafer **1500**, the entire semiconductor wafer **1500** being used essentially intact as a computer, which can also include a Faraday Cage and a siped compartment. FIG. 24B is a side cross section of three stacked wafers **1500**. FIG. 24C is another top view of a wafer **1500**, but subdivided into smaller components, such as half sections and quarter sections.

FIGS. 25A-25B are modifications of FIGS. 29A-29B of the '657 application incorporated by reference herein above. FIG. 25B shows a microchip **1501** as a separated die in a package **1503** including the applicant's internal sipe inventions **510/511/513** and the Faraday Cage **300**.

FIGS. 26A-26B is FIGS. 7A-7B with the addition of Faraday Cages, as well as stacked dies in FIG. 7B.

FIGS. 27A-27B are like FIGS. 28A-28B of the '033 and '930 Applications incorporated above shows in cross-section

an example of a tire **535**, such as for a wheel **533** of a transportation vehicle, with a device **510**.

It is understood that the reference numbers identified in this application and in U.S. Patent Applications '665, '033, and '930 incorporated by reference herein, are used consistently throughout the application such that like reference numbers are used to describe the same or like elements.

#### DETAILED DESCRIPTION

FIGS. 1-9 of this application are FIGS. 1-6, 52, 61, 67, 74, and 79 of both the applicant's U.S. application Ser. No. 11/802,033 filed May 18, 2007 and published on Apr. 10, 2008 as Pub. No. US 2008/0083140 A1 and PCT Application PCT/US2007/011976 filed 18 May 2007 and published on 31 Jan. 2008 as Int. Pub. No. WO 2008/013594 A2, as well as U.S. application Ser. No. 11/802,930 filed May 25, 2007 and published on Apr. 17, 2008 as Pub. No. US 2008/0086916 A1; all three applications are incorporated herein by reference. In addition, FIGS. 1-6 (except 6D-6F) of this application are FIGS. 83-88 of both the applicant's U.S. application Ser. No. 11/282,665 filed Nov. 21, 2005 and published on Nov. 9, 2006 as Pub. No. US 2006/0248749 A1 and PCT Application PCT/US2005/042341 filed 21 Nov. 2005 and published on 1 Jun. 2006 as Int. Pub. No. WO 2006/058013 A2, both of which are incorporated herein by reference.

FIGS. 1-9 show the applicant's prior inventions incorporating forms of insertable devices with one or more internal (or mostly internal) sipes, including slits (or channels or grooves and other shape, including geometrically regular or non-regular shapes, such as anthropomorphic shapes), into a large variety of products, including footwear and orthotics, athletic, occupational and medical equipment and apparel, padding for equipment and furniture, balls, tires and any other structural or support elements in a mechanical, architectural or any other device.

New reference numerals used in the FIGS. 1-79 are further defined as follows:

Ref. No **500**: An outer compartment, such as an outer compartment **161** or chamber **188** or bladder, at least partially or mostly or entirely enclosing a space within the outer compartment/chamber/bladder **500**, which can be located anywhere in a footwear sole or upper or both or other article described in this application. Construction and materials can be, as one embodiment example, simpler in shape but otherwise similar to those used in any commercial samples of Nike Air™.

Ref. No **501**: An inner compartment, such as an inner compartment **161** or chamber **188** or bladder, is located inside the enclosed space of the outer compartment/chamber/bladder **500**. Construction and materials of the inner compartment/chamber/bladder **501** can be, as one embodiment example, like those used in any commercial samples of gas bladders in Nike Air™.

Ref. No. **502**: Structural element that is optional anywhere within either outer compartment/chamber/bladder **500** or inner compartment/chamber/bladder **501**, of which a **501** embodiment is shown; any flexible, resilient material can be used, including structures molded into the shape of (and using the material of) the compartment/chamber/bladder **500** or **501**, as is very common in the art, such as many commercial samples of gas bladders used in Nike Air™, as well as foamed plastic or plastic composite or other materials, like Nike Shox™ or Impax™ or Reebok DMX™ or New Balance N-ergy™. In addition, other materials can be used directly within a **501/500** compartment or can connected to or through a **501/500** compartment, as in the

cushioning components of the shoe sole heel of commercial samples of Adidas 1™, including electromechanical, electronic, and other components. Some devices may benefit from the use of rigid or semi-rigid materials for part or all of a media within a compartment.

Ref. No. **503**: Attachment of two compartment/chambers/bladders **500/501**, including particularly attachment of outer **500** to inner **501**; any practical number of attachments of any form using any materials can be used, including glue.

Ref. No. **504**: Media contained within all or part of compartment/chamber/bladder **500** or **501**, particularly **501**, can be any useful material, such as gas (including, as an example, gas used in Nike Air™ or ambient air, liquid or fluid, gel, or foam (such as a plastic like PU or EVA or equivalent or rubber (natural or synthetic) or combination of two or more; encapsulation of foam is optional); material particles or coatings, such as dry coatings like Teflon™ can also be used. An optional element in an outer compartment/chamber **500** (or an inner compartment/chamber **501** that itself contains an inner compartment/chamber, as in FIG. **87**).

Ref. No. **505**: Internal sipe or slit or channel or groove for flexibility, such as between inner and outer compartment/chamber **500/501** (or bladder) surfaces, as one embodiment example; such surfaces can be substantially parallel and directly contact in one useful embodiment example, but are not attached so that at least parts of the two surfaces can move relative to each other, such as to facilitate a sliding motion between surfaces; the surfaces can be in other useful forms that allow portions of the surfaces to be proximate to each other but not contacting in an unloaded condition or in a partially loaded condition or in a maximally loaded condition.

Ref. No. **506**: Media of internal sipe **505**; media **506** can be any useful material like those used in media **504**; media **506** can be located in part or all of **505** to decrease (or increase) sliding resistance between **500/501** or **505** surfaces, for example, to lubricate the surfaces with any suitable material; silicone or Teflon™ can be used, for example; an optional element.

Ref. No. **507**: Metal particles.

Ref. No. **508**: Shock absorbing fluid containing **507**; a magnetorheological fluid.

Ref. No. **509**: Electromagnetic field-creating circuit.

Ref. No. **510**: A flexible insert or component including siped compartments **161** or chambers **188** or bladders used for example as outer and inner compartments/chambers/bladders **500/501** for footwear soles or orthotics or uppers or other uses; a useful embodiment being two or more compartment or chambers (or bladders) **161/188** (or mix) that are separated at least in part by an internal sipe **505**, including the example of at least one **501** (either **161/188** or bladder) inside at least one **500** (either **161/188** or bladder) and being separated by an internal sipe **505**.

Ref. No. **580**: Computer or computer component.

Ref. No. **581**: Micro-technology and nanotechnology devices, including a semiconductor microchip device (a part of a die or an entire die or multiple dies assembled together) microelectromechanical systems (MEMS), field-programmable gate arrays (FPGA's) and faraday cages, photovoltaic cells, fuel cells, batteries, and including devices assembled at the molecular or atomic scale.

FIGS. **1-7** show, as numeral **510**, examples of a device or flexible insert including siped compartments **161** or chambers **188** or bladders (another term used in the art) for use in any footwear soles, including conventional soles **22** or the applicant's prior inventions, including footwear/shoe soles **28** and

midsole inserts **145** as described in applicant's published '087 Application and Ser. No. 11/282,665 U.S. application published Nov. 9, 2006, as Pub. No. US 2006/0248749 A1 incorporated by reference, or for orthotics **145** as described in the applicant's published '034 U.S. Application, '869 Patent, and WO 02/09547 WIPO publication, as well as to be published by WIPO PCT Application Number PCT/US2005/042341, all incorporated by reference herein, including for uppers for footwear or orthotics (or including uppers), or for other flexibility uses in athletic equipment like helmets and apparel including protective padding and guards, as well as medical protective equipment and apparel, and other uses, such as protective flooring, improved furniture cushioning, balls and tires for wheels, and other uses.

The device or flexible insert with siped compartments or chambers **510** include embodiments like two or more of either compartments **161** or chambers **188** or bladders (or a any mix including two or more of a compartment, a chamber, and a bladder) that are separated at least in part or in several parts or mostly or fully by an internal sipe **505**. The flexible insert **510** can be inserted during assembly of an article by a maker or manufacturer or is insertable by a user or wearer (into an article like a shoe, for example, as part of a removable midsole insert **145** described above), or integrated into the construction of a device as one or more components.

Siped compartments or chambers **510** include example embodiments such as FIGS. **1-7**, which generally show at least one inner compartment **161** or chamber **188** inside at least one other outer compartment **161** or chamber **161**; and the two compartments/chambers **161/188** being separated by an internal sipe **505**.

One practical example embodiment of the invention is any prior commercial embodiment of Nike Air™ gas bladder or compartment (like typical examples in FIGS. **12-16** of U.S. Pat. No. 6,846,534, which is hereby incorporated by reference) that is installed unattached, as is, located within the space enclosed partially or fully by a new, slightly larger outer compartment of one additional layer of the same or similar material, with the same or a simpler or the simplest geometric shape; that is, not necessarily following indentations or reverse curves, but rather incorporating straighter or the straightest lines, as seen in cross-section: for example, following the outermost side curvature seen in FIGS. **12-16**, but with upper and lower surfaces that are substantially flat and parallel (or curved and parallel), to facilitate ease of movement between the two surfaces of the sipe **505** formed, increasing the resulting flexibility.

The new additional, outer compartment thus thereby has created by its presence an internal sipe **505** between the two unconnected compartments. The new internal sipe **505** provides much greater flexibility to any footwear sole **22** or **28**, since it allows an inner, otherwise relatively rigid Nike Air™ compartment structure to become an inner compartment **501** (instead of typically being fixed into the other materials such as EVA of the footwear sole) to move freely inside the new outer compartment **500**, which becomes a new compartment that is fixed to the footwear sole, rather than the conventional Nike Air™ bladder. The flexibility improvement allows the shoe sole to deform under a body weight load like a wearer's bare foot sole, so that stability is improved also, especially lateral stability.

The result is that the conventional, inner Nike Air™ compartment—now contained by a new outer compartment—can move easily within the overall footwear sole, allowing the sole to bend or flex more easily in parallel with the wearer's bare foot sole to deform to flatten under a body weight load, including during locomotion or standing, so that footwear

sole stability is improved also, especially lateral stability. The extent to which the inner Nike Air™ compartment is “free-floating” within the new outer compartment can be controlled or tuned, for example, by one or more attachments (permanent or adjustable) to the outer compartment or by the media

The internal sipe **505** includes at least two surfaces that can move relative to each other to provide a flexibility increase for a footwear sole so that the shape of the footwear sole can deform under a body weight load to better parallel to the shape of the barefoot sole of a wearer under a same body weight load. The relative motion between the two internal sipe **505** surfaces increases the capability of the footwear sole to bend during locomotion under a wearer’s body weight load to better parallel the shape of said wearer’s bare foot sole.

Also, the sliding motion between internal support surfaces within the shoe sole **28** allowed by internal sipe **505** in response to torsional or shear forces between a wearer’s foot and the ground assists in controlling and absorbing the impact of those forces, whether sudden and excessive or chronically repetitive, thereby helping to protect the wearer’s joints from acute or chronic injury, especially to the ankles, knees, hips, lower back, and spine.

A benefit of the siped compartments/chambers **510** is that, as a single unitary component, it can be used in any conventional manner in constructing the footwear sole **28**, generally like that used with a conventional single layer compartment such as used in Nike Air™; i.e. the outer surface of **510** can, as a useful embodiment, adhere to the adjacent materials like plastic such as PU (polyurethane) or EVA (ethyl vinyl acetate) or other plastic or rubber of the footwear sole that contact the **510** component, just as would be the case with the outer surface of existing single compartment **161** or chamber **188** of commercial examples of Nike Air™. However, the internal sipe **505** formed by the use of an inner compartment/chamber **501** in the siped compartment/chamber **510** provides flexibility in a footwear sole **28** that is absent in the relatively rigid footwear sole **28** formed with a conventional, single layer compartment **161** or chamber **188** of the many Nike Air™ commercial examples.

The sipe surfaces can in one useful example embodiment be formed by the inner surface (or part or parts of it) of the outer compartment **500** and the outer surface (or part or parts of it) of the inner compartment **501**. Such sipe surfaces can be substantially parallel and directly contact each other in one useful embodiment example, but the two surfaces are generally not attached to each other, so that the sipe surfaces can move relative to each other to facilitate a sliding motion between the two surfaces.

The sipe surfaces can be in other useful forms that allow portions of the surfaces to be proximate to each other in an unloaded condition, rather than contacting; such surfaces can make partial or full direct contact under a wearer’s body weight load (which can vary from a fraction of a “g” to multiple “g” forces during locomotion) or remain somewhat separated; the amount of sipe surface area making direct contact can also vary with a wearer’s body weight load. The sipes surfaces also may not be parallel or only partially parallel, such as the areas of direct surface contact or proximal surface contact.

To preclude the surfaces of the internal sipe **505** from directly contacting each other (whether loaded or unloaded), the sipe surfaces can include an internal sipe media **506** located between the surfaces to reduce friction by lubrication and increase relative motion and therefore flexibility. Useful example embodiments of the internal sipe media **506** include any useful material known in the art (or equivalent), such as a

liquid like silicone as one example, a dry material like Teflon™ as another example, or a gas like that used in Nike Air™ as a further example. The media **506** can be located in all of the sipe **505** or only part or parts, as shown in FIGS. 1-6.

The media **506** can be used to decrease (or increase) sliding resistance between the inner surfaces of the sipe; for example, to lubricate with any suitable material known in the art. The internal sipe media **506** is an optional feature.

The attachments **503** can be simply passive (i.e. static) or actively controlled by electronic, mechanical, electromagnetic, or other useful means. The attachments **503** can, for example, be designed to break away as a failsafe feature to compensate for a predetermined extreme torsional load, for example, to reduce extreme stress on critical joints (in lieu of a wearer’s cartilage, tendons, muscle, bone, or other body parts being damaged); the attachments **503** can then be reset or replaced (or, alternatively, return automatically upon relief of extreme stress to a normal position).

Example embodiments of the compartments and chambers **500/501** can include a media **504** such as a gas (like that used in Nike Air™ or ambient atmospheric air), a liquid or fluid, a gel, a foam (made of a plastic like PU or EVA, both of which are common in the footwear art, or equivalent, or of a rubber (natural or synthetic) or blown rubber or a rubber compound or equivalent or of another useful material or of a combination of two or more of the preceding foam plastic/rubber/etc.) or a useful combination of one or more gas, liquid, gel, foam, or other useful material.

FIGS. 2A, 3A, and 4A show examples of embodiments of siped compartment/chamber/bladders **510** wherein either the inner compartment/chamber/bladder **501** or the outer compartment **500** can have one or more openings, for pressure equalization, assembly facilitation, or other purposes.

FIG. 5A shows an example embodiment with an inner compartment/chamber/bladder **501**<sup>1</sup> having a smaller inner compartment/chamber/bladder **501**<sup>2</sup>; additional smaller inner compartments **501** are possible in a similar progression, either enclosed within the previous larger inner compartment **501** or within the same **501** or **500**.

FIG. 6A shows an example embodiment with two inner compartment/chamber/bladders **501**<sup>1</sup> and **501**<sup>2</sup> which are layered within outer compartment/chamber/bladder **500**; additional compartment/chamber **501** layers can be useful also.

FIG. 1B shows an example embodiment of the device **510** in a horizontal plane view of FIGS. 1A, 2A, 3A, 4A, 5A, and 6A.

FIG. 1C is an exploded perspective view showing the relationship of an insert device **510**, which has a siped compartment or chamber or bladder, with a midsole **148**, bottom sole **149**, and upper **21** of a shoe or any other footwear. The midsole **148** and bottom sole **149** (and any additional layers not shown) together form a shoe sole which can be any footwear sole, including any conventional sole **22** or any sole **28** according to one of the applicant’s patents or applications. In the simple example shown, the device **510** can be inserted during a conventional manufacturing or assembly process or by a footwear wearer and can be located anywhere in the footwear sole and/or upper.

FIG. 1E shows a detailed frontal plane cross section of an example conventional commercial gas bladder/compartment/chamber shown as inner bladder or compartment or chamber **501** in schematic perspective in FIG. 1D. FIG. 2F shows the same detailed cross sectional view of the same inner bladder or compartment or chamber **501** enveloped by an outer bladder or compartment or chamber **500** forming an insertable siped compartment **510**, including wherein all or part of the sipe **505** is a slit.

FIG. 7A shows a perspective view of a laptop personal computer **580** or any other electronic device with one of a potential multitude of potential example embodiments of the applicant's **510** or **511** or **513** inventions described above are used in two areas, but other useful embodiments with any of the previously described variations can be employed beneficially. For example, as shown, the **510/511/513** inventions can be used for cushioning selected corners of the laptop or can be integrated in the laptop frame in the same or other areas; and/or individual components of the laptop computer such as a harddrive can be protected by being mounted in a protected **510/511/513**, such as the housing of the hard-drive forming an inner compartment **501** of the **510** siped compartment invention.

FIG. 7B shows a semiconductor microchip device **581** example including a part of a die or an entire die or multiple dies assembled together using the applicant's **510/511/513** invention; other devices **581** can include other micro-technology and nanotechnology devices, including microelectromechanical systems (MEMS), field-programmable gate arrays (FPGA's) and faraday cages, photovoltaic cells, fuel cells, batteries, and including devices assembled at the molecular or atomic scale. The FIG. 7B example embodiment can include a single layer of die or dies or can include a stacked arrangement of two or more layers of separate dies. FIG. 7C shows a cross section of the semiconductor microchip device **581** example of FIG. 7B, showing a stacked arrangement of three layers of separate dies **581#1**, **581#2**, and **581#3**.

FIGS. 7C and 7D show other examples such as electronic game controllers or any other remote controllers **580** and cell phones **580** that can beneficially incorporate any of the applicant's **510/511/513**.

FIG. 8 shows a chart displaying "Approximate Comparison of Hardness Scales". Products using the **510** or **511** or **513** inventions can be made of any material and any material hardness shown in chart, including Rockwell C and B Scales and Brinell Hardness Scale, including metallic and ceramic, generally for non-cushioning, relatively rigid structural elements into which a degree of flexibility is to be introduced using the applicant's **510/511/513** inventions, specific examples of which are shown in FIGS. 7A-7B.

FIG. 9A shows that, in an analogous way, especially to the thicker heel portion of a typical shoe sole, a thick urban area telephone book has in effect hundreds of mostly "internal sipes", each page being in effect separated by a horizontal internal slit from each adjacent page, each of which thereby is able to move freely relative to each other, resulting in a flexible telephone book that bends quite easily as is well known by all, while at the same time relatively stable when a vertical force like body weight is applied. FIG. 9B shows, in contrast, if the same wood fiber material with the same dimensions as a thick telephone book were formed instead into a single piece of wood with no pages, like a solid particle board, it would be quite rigid with little flexibility, although it will support a body weight stably. FIG. 9C shows if, instead, the sipes were rotated 90 degrees into vertical slits and open to the bottom, so that the spine of a much wider telephone book with shorter pages is on top (in the form of a shoe sole with deep open external sipes, those external sipes would also provide a substantial amount of flexibility like that of the human foot sole, but at the cost of excessive instability when a vertical force like body weight is applied, as is obvious from common experience, since the pages will splay out uncontrollably.

FIGS. 10-22 of this application are FIGS. 10A-10I, 16A-16Z, 16AA, and 16AB, 17A-17D, 21B, 22A, 23A-23E, 25A-25D, 26A-26C, 27A-27H, 28, 29A, 30A-30C, and 31 of both

the applicant's U.S. application Ser. No. 10/802,049 filed May 17, 2004 and published on Oct. 28, 2004 as Pub. No. US 2004/0215931 A1.

As shown in FIGS. 10A-10F, to deal with operational and security issues, it may be beneficial for individual users to have one microprocessor or equivalent device that is designated, permanently or temporarily, to be a master **30** controlling device (comprising hardware and/or software and/or firmware and/or other component) that remains inaccessible (using, for example, a hardware and/or software and/or firmware and/or other component firewall **50**) directly by the network but which controls the functions of the other slave microprocessors **40** when the network is not utilizing them.

For example, as shown in FIG. 10A, a typical PC **1** may have four or five microprocessors (even on a single microprocessor chip), with one master **30** and three or four slaves **40**, depending on whether the master **30** is a controller exclusively (through different design of any component part), requiring four slave microprocessors **40**; or the master microprocessor **30** has the same or equivalent microprocessing capability as a slave **40** and multiprocesses in parallel with the slave microprocessors **40**, thereby requiring only three slave microprocessors **40**. The number of PC slave microprocessors **40** can be increased to virtually any other number, such as at least about eight, about 16, about 32, about 64, about 128, about 256, about 512, about 1024, and so on. These multiples are not required, and the number of PC master microprocessors **30** may be increased. Also included is an internal firewall **50** between master **30** and slave **40** microprocessors. As shown in preceding FIGS. 1-9, the PC **1** in FIG. 10A may be connected to a network computer **2** and to the Internet or WWW or present or future equivalent or successor **3**, like the Grid (or MetalInternet).

Other typical PC hardware components such as hard drive **61**, floppy diskette drive **62**, compact disk-read only memory (CD-ROM) **63**, digital video disk (DVD) **64**, Flash memory **65**, random access memory (RAM) **66**, video or other display **67**, graphics card **68**, and sound card **69**, as well as digital signal processor or processors, together with the software and/or firmware stored on or for them, can be located on either side of internal firewall **50**, but such devices as the display **67**, graphics card **68** and sound card **69** and those devices that both read and write and have non-volatile memory (retain data without power and generally have to be written over to erase), such as hard drive **61**, Flash memory **65**, floppy diskette drive **62**, read/write CD-ROM **63** or DVD **64** may be located on the PC user side of the internal firewall **50**, where the master microprocessor is also located, as shown in FIG. 10A, for security reasons; their location can be flexible, with that capability controlled such as by password-authorized access.

Alternately, any of these devices that are duplicative (or for other exceptional needs) like a second hard drive **61'**, can be located on the network side of the internal firewall **50**. RAM **66** or equivalent or successor memory, which typically is volatile (data is lost when power is interrupted), should generally be located on the network side of the internal firewall **50**, but some can be located with the master microprocessor to facilitate its independent use.

However, read-only memory (ROM) devices including most current CD drives (CD-ROM's) **63'** or DVD's (DVD-ROM) drives **64'** can be safely located on the network side of the internal firewall **50**, since the data on those drives cannot be altered by network users; preemptive control of use may remain with the PC user.

However, at least a portion of RAM can be kept on the Master **30** microprocessor side of the internal firewall **50**, so

that the PC user can retain the ability to use a core of user PC 1 processing capability entirely separate from any network processing. If this capability is not desired, then the master 30 microprocessor can be moved to the network side of the internal firewall 50 and replaced with a simpler controller on the PC 1 user side, like the master remote controller 31 discussed below and shown in FIG. 10I.

The master microprocessor 30 may also control the use of several or all other processors 60 owned or leased by the PC user, such as home entertainment digital signal processors 70, especially if the design standards of such microprocessors in the future conform to the requirements of network parallel processing as described above. In this general approach, the PC master processor uses the slave microprocessors or, if idle (or working on low priority, deferrable processing), makes them available to the network provider or others to use. Wireless connections 100, including optical wireless, are expected to be extensively used in home or business network systems, including use of a master remote controller 31 without (or with) microprocessing capability, with broad bandwidth connections such as fiber optic cable connecting directly to at least one component such as a PC 1, shown in a slave configuration, of the home or business personal network system; that connection links the home system to the network 2 such as the Internet 3, as shown in FIG. 10I. A business system may include broadband such as fiber optic or optical wireless links to most or all personal computers PC 1 and other devices with microprocessors, such as printers, copiers, scanners, fax machines, telephone and video conferencing equipment; other wired or wireless links also can be used.

A PC 1 user can remotely access his networked PC 1 by using another networked master microprocessor 30 on another PC 1 and using a password or other access control means for entry to his own PC 1 master microprocessor 30 and files, as is common now in Internet and other access. Alternately, a remote user can simply carry his own digitally stored files and his own master microprocessor or use another networked master microprocessor temporarily has his own.

In the simplest configuration, as shown in FIG. 10B, the PC 1 may have a single master microprocessor 30 and a single slave microprocessor 40, separated by an internal firewall 50, with both processors used in parallel or multitasking processing or with only the slave 40 so used, and connected with broad bandwidth such as optical fiber wire 99 to a network computer 2 and Internet 3 and successors like the Grid (or MetaInternet). Virtually any number of slave microprocessors 40 is possible. The other non-microprocessor components shown in FIG. 10A above may also be included in this simple FIG. 10B configuration.

As shown in FIG. 10C, microchips 90 are expected to integrate most or all of the other necessary computer components (or their present or future equivalents or successors), like a PC's volatile memory like RAM 66 (such as DRAM), graphics 82, sound 83, power management 84, network communications 85, and video processing 86, possibly including modem 87, non-volatile memory like flash (or magnetic like MRAM or ovonic unified memory) 88, system BIOS 88', digital signal processor (DSP) or processors 89, and other components or present or future equivalents or successors) and internal bus, on a single chip 90 (silicon, plastic, or other), known in the industry as "system on a chip". Such a PC microchip 90 can have the same architecture as that of the PC 1 shown above in FIG. 10A: namely, a master control and/or processing unit 93 and one or more slave processing units 94 (for parallel or multitasking processing by either the PC 1 or the Network 2), separated by an internal firewall 50 and connected by broad bandwidth wire 99 such as optical fiber

cable to a network computer 3 and the Internet 3 and successors like the Grid (or MetaInternet). Alternatively, microchip 90 can be an "appliance" system on a chip.

Existing PC components with mechanical components like hard drive 61, floppy or other removable diskette 62, CD-ROM 63, and DVD 64, which are mass storage devices with mechanical features that will likely not become an integral part of a PC "system of a chip" may still be capable of connection to a single PC microchip 90 and control by a single PC master unit 93.

In the simplest multi-processor case, as shown in FIG. 10D, the chip 90 has a single master unit 93 and at least one slave unit 94 (with the master having a controlling function only or a processing function also), separated by an internal firewall 50 and connected by broad bandwidth wire 99 such as fiber optic cable to a network computer 3 and the Internet 3 (and successors like the Grid or MetaInternet). The other non-microprocessor components shown in FIG. 10A above may also be included in this simple FIG. 10D configuration.

As noted above, any computer may be both a user and provider, alternatively—a dual mode operating capability. Consequently, any PC 1 within the network 2, connected to the Internet 3 and successors like the Grid (or MetaInternet), can be temporarily a master PC 30 at one time initiating a parallel or multitasking processing request to the network 2 for execution by at least one slave PC 40, as shown in FIG. 10E. At another time the same PC 1 can become a slave PC 40 that executes a parallel or multitasking processing request by another PC 1' that has temporarily assumed the function of master 30, as shown in FIG. 10F. The simplest approach to achieving this alternation is for both master and slave versions of the parallel processing software to be loaded in each or every PC 1 that is to share in the parallel processing, so each PC 1 has the necessary software means, together with minor operational modifications, such as adding a switching means by which a signaled request for parallel processing initiated by one PC 1 user using master software is transmitted to at least a second PC 1, triggering its slave software to respond by initiating parallel processing.

As shown in FIGS. 10G and 10H, which are parallel to FIGS. 10E and 10F, the number of PC slave processors 40 can be increased to any virtually other number, such as at least about 4; as shown, the processing system is completely scalar, so that further increases can occur to, for example, about eight, about 16, about 32, about 64, about 128, about 256, about 512, about 1024, and so on; the PC master microprocessors 30 can also be increased.

In summary, as noted above relative to FIG. 10I, a PC 1 can function as a slave PC 40 and be controlled by a master controller 31, which can be remote and which can have limited or no microprocessing capability, but can as well have similar or greater capability. Such a master controller 31 can be located on the PC user side of the internal firewall 50, under the control of the PC user, while the microprocessors 40 reside on the network side of the internal firewall 50. The master controller 31 may receive input from the PC user by local means such as keyboard, microphone, videocam or future hardware and/or software and/or firmware or other equivalent or successor interface means (as does a master processor 40) that provides input to a PC 1 or microprocessor 30 originating from a user's hand, voice, eye, nerve or nerves, or other body part; in addition, remote access by telephone, cable, wireless or other connection may also be enabled by a hardware and/or software and/or firmware and/or other means with suitable security such as password controlled access. Similarly, relative to a PC "system on a chip", a master controller unit (which could be capable of being accessed by

the PC user through a remote controller 31) with only a controlling capability can be located on the PC user side of the internal firewall 50, under the control of the PC user, while the slave processor units 94 would reside on the network side of the internal firewall 50.

FIGS. 10A-10C show PC 1 with an internal firewall 50 that is configurable through either hardware and/or software and/or firmware and/or other means; software configuration is easiest and most typical, but active motherboard hardware configuration is possible and may present some security advantages, including a use of manual or electromechanical or other switches or locks. FIG. 10A shows a CD-ROM 63' that has been placed by a PC user on the network side of an internal firewall 50 from a previous position on the PC user side of an internal firewall 50, which was shown in FIG. 10A. The settings of an internal firewall 50 may default to those that safely protect the PC 1 from uncontrolled access by network users, but with capability for the relatively sophisticated PC user to override such default settings and yet with proper safeguards to protect the unsophisticated user from inadvertently doing so; configuration of an internal firewall 50 may also be actively controlled by a network administrator in a local network like that of a business, where a PC user may not be the owner or leaser of the PC being used, either by remote access on the network or with a remote controller 31.

Similarly, FIGS. 10C and 10D show a PC "system on a chip" 90 with an internal firewall 50 that is configurable through either hardware and/or software and/or firmware and/or other means; software configuration is easiest and most typical. Active configuration of the integrated circuits of the PC microchip 90 is also possible and may present some speed and security advantages. Such direct configuration of the circuits of the microchip 90 to establish or change its internal firewall 50 could be provided by the use of field-programmable gate arrays (or FPGA's) or their future equivalents or successors; microcircuit electromechanical or other switches or locks can also be used potentially. For example, slave processing unit 94 can be moved to the PC user side of an internal firewall 50 from a network side position. The same active configuration of the chip circuit can use FPGA's for the simplest form of multiprocessing microchip 90 with a single slave unit 94, transferring its position to the PC user's side of an internal firewall 50 from a network side as shown by slave processing units 94 in FIGS. 10C and 10D.

FIGS. 11G-11I show the applicant's new hierarchical network structure and function applied to the design of a personal computer PC 1, as discussed previously in FIGS. 10A and 10B of the '049 Application. FIG. 11G shows the simplest general design, with a master  $M_1$  microprocessor 30 and two slave  $S_{21}$  and  $S_{22}$  microprocessors 40. FIG. 11H shows the same network structure with an additional level of slave microprocessors 40,  $S_{31}$  through  $S_{34}$ , while FIG. 11I shows the same network structure as FIG. 11H with an additional level of slave microprocessors 40,  $S_{41}$  through  $S_{48}$ . As shown in these examples, this network structure is completely scalar, including any practical number of slave microprocessors 40 on any practical number of processing levels.

FIG. 11J shows a useful embodiment in which each microprocessor 30 and 40 has, in addition to internal cache memory, its own random access memory (RAM) 66 or equivalent memory (volatile like DRAM or non-volatile like Flash memory, magnetic such as MRAM memory, or ovonic unified memory), integrated on-microchip 90 or separate off-microchip. A significant amount of such microchip RAM (volatile like DRAM or non-volatile like Flash memory, magnetic such as MRAM memory, or ovonic unified memory), significantly greater than cache memory (SRAM) and other

on-chip memory used on microprocessor chips today, can be beneficial in improving the efficient operation of the microprocessor; if located off microprocessor chip, the size of such memory can substantially exceed the size of the associated microprocessor, but an on-microprocessor chip location for DRAM or Flash (or MRAM or ovonic memory), like cache (SRAM) memory, offers the best potential for improving microprocessor speed and efficiency. The design can also incorporate (or substitute) conventional shared memory or RAM 66' (i.e. memory used by all, or some, of the microprocessors 30 or 40 (or 90) of the personal computer PC 1).

FIGS. 11A-11C are parallel to FIGS. 11G-11I above, but show PC microprocessor 90 architecture rather than macro PC 1 architecture; a PC microprocessor 90 is as earlier described in FIG. 10C, a personal computer on a microchip.

FIG. 11D is like FIG. 11J, also except for showing PC microprocessor 90 architecture instead of PC 1 architecture. FIG. 11D shows a useful embodiment in which each PC microprocessor 93 or 94 has its own integrated on-microchip (or separate off microchip) random access memory (RAM) 66 or equivalent memory (volatile like DRAM or non-volatile, like Flash memory, magnetic such as MRAM memory, or ovonic unified memory). A significant amount of such RAM or other memory, significantly greater than cache (SRAM) memory or other on-microchip memory used on microprocessor chips today, can be beneficial in improving the efficient operation of the microprocessor; if located off-microprocessor chip, the size of such memory can substantially exceed the size of the associated microprocessor, but an on-microprocessor chip 90 location for DRAM or Flash (or MRAM or ovonic memory), like cache (SRAM) memory, offers the best potential for improving microprocessor speed and efficiency. The microchip design can also incorporate (or substitute) conventional shared memory or RAM 66' (i.e. memory used by all, or some, of the PC microprocessors 93 or 94 of the personal computer PC microprocessor 90).

FIGS. 11A-11D show a different and improved basic microchip architecture which can exclude or reduce the currently used superscalar approach in microprocessors to execute multiple instructions during each clock cycle. The FIGS. 11A-11D architecture is much simpler and, by integrating memory with microprocessor, reduces memory bottlenecks. The simplicity of the FIGS. 11A-11D microchip design, which may have little or no superscalar components, compared to conventional superscalar designs (the inherent extreme complexity of which creates a very substantial memory overhead), can result in the use of a much greater proportion of independent, non-superscalar processors per microchip, exclusive of integrating memory or RAM 66 onto the microprocessor chip 90, as discussed in FIG. 11D.

FIGS. 11G-11J, by using the same architecture for PC 1 networks as FIGS. 11A-11D, import the same advantage of microchip parallel processing performance to parallel processing in PC 1 networks.

FIG. 11K shows a direct connection of optical fiber 99 from Internet 3 (or another network) to random access memory (RAM) microchip 66'. The connection may be at a central portion 140 of RAM chip 66' to provide equal access to stored data on RAM chip 66'. The direct connection can be anywhere on RAM chip 66'. Digital signal processor (DSP) 89 is on RAM chip 66' for connection with optical fiber 99. RAM chip 66' is for shared memory use among PC's 1 and for broadcast use. RAM chip 66' can include volatile or non-volatile (flash-type) memory. RAM chip 66' can have more than one DSP 89, such as shown in FIG. 20B.

All FIGS. 11A-11K, like the preceding figures of this application, show sections of a network of personal comput-



ers PC 1 (or PC microprocessors 90) or microprocessors 30 or 40 which can be parts of the WWW or Internet or Internet II or the Next Generation Internet (meaning connected to it) or Intranets or Extranets or other networks.

Also, except for FIGS. 11A-11C and 11G-11I, all of the FIG. 11 series show personal computers PC 1 and microprocessors 30 or 40 as occupying the same location. This dual representation was done for economy of presentation and to show the parallel functionality and interchangeability in conceptual terms of personal computer PC 1 and microprocessors 30 or 40 in the structure of the new network. So, taking FIG. 16A as an example, M<sub>1</sub>, S<sub>21</sub> and S<sub>22</sub> show three personal computers PC 1 or, alternatively, one microprocessor 30 and two microprocessors 40.

As noted initially in FIG. 10C, a personal computer PC 1 can be reduced in size to a PC microprocessor chip 90, so preceding Figures showing personal computer PC 1 also generally represent PC microprocessor chip 90.

Finally, FIGS. 11A-11K show a mix of electrical and optical connections, including wired 99, especially connections such as optical glass fiber or omniguides, and wireless 100, especially wireless optical (and mixtures of both in a single figure), and dense wave division multiplexing (DWDM). Generally, either 99 or 100 or a mix can be used relatively interchangeably in the network inventions shown (as well as in prior figures), though in some embodiments either highest transmission speed (i.e. broadest bandwidth) or mobility (or some other factor) may dictate a use of wired or wireless. Generally, fiber optic wire 99 and dense wave division multiplexing (DWDM) may provide the most advantageous transmission means because it has the greatest bandwidth or data transmission speed, so it may be used for connections between personal computers and microchips, including direct connections, although optical wireless 100 also offers very high bandwidth, especially with dense wave division multiplexing (DWDM). Other wireless 100 (but also including optical wireless), including with DWDM, can be used where mobility is a paramount design criteria.

The FIG. 11 embodiments can be combined with, or modified by incorporating, any other network system architectures (including client/server or peer to peer) or any other topologies (including ring, bus, and star) either well known now in the art or their future equivalents or successors.

Any of the embodiments shown in FIGS. 11A-11K can be combined with any one or more of the preceding or subsequent figures of this application to provide a useful improvement over the art.

The parallel processing network architecture shown in the preceding FIGS. 11A-11K and in earlier figures has several features unique to its basic design that provide for the security of personal computers PC 1 (or PC microprocessor 90) or microprocessor 40 that share other computers for parallel and multi-tasking processing. First, the slave personal computers PC 1 (or microprocessors 40) each have only part of the operation (for large operations, only a very small part) and therefore unauthorized surveillance of a single PC 1 can provide only very limited knowledge of the entire operation, especially in only a relatively local area in which switching or routing was employed. Second, the addresses of the slave personal computers PC 1 (or microprocessors 40) are known or traceable, and therefore are not protected by anonymity (like hackers usually are) in case of unauthorized intervention. In addition, cryptography can be employed, with on microprocessor chip 30, 40, or 90 hardware 55 being used in some embodiments due to efficiency, although software and firmware can also be used, or a separate PC 1 hardware-based component 56 like an encryption microchip can be used; with

either encryption component 55 or 56, micro electromechanical locks can be used to prevent access other than by the direct physical user; other MicroElectroMechanical System (MEMS) devices located on microchips like PC90 can be used for access prevention or other functions. Nonetheless, these inherent strengths can be substantially reinforced, as indicated in FIGS. 12B-12D.

FIG. 12A shows at least one internal firewall 50 performing its conventional function of keeping out intruders such as hackers from the Internet 3 from unauthorized access for either surveillance of, or intervention in, a user's personal computer PC 1 (or PC microprocessor 90) or master microprocessor 30.

FIG. 12B shows that, since Internet users can, as enabled by the applicant's network structure invention, use one or more of the slave microprocessors 40 of another's personal computer PC 1 (or PC microprocessor 90) for parallel (or multi-tasking) processing, the at least one internal firewall 50 has a dual function in also protecting Internet 3 use (or other shared use on a network) from unauthorized surveillance or intervention by a PC 1 owner/user who is providing the shared resources. To maintain the privacy necessary to operate such a cooperatively shared network arrangement, unauthorized surveillance or intervention must be carefully prevented by hardware/software/firmware or other means.

FIG. 12C therefore shows master M personal computer PC 1 (or PC microprocessor 90) using the slave S<sub>2</sub> microprocessor 40 of a different personal computer, PC 1', which is available for Internet 3 (or other net) shared use, while internal firewall 50' blocks unauthorized access into PC 1' by PC 1 (although PC 1' owner/user can always interrupt a shared operation and take back control and use of slave S' microprocessor 40, which then triggers off-loading action to compensate, as discussed above in FIGS. 16I-16J of the '049 Application).

FIG. 12D is similar to FIG. 12C, but shows a PC microprocessor 90 with a slave microprocessor 94 being used by Internet 3 users (or other net), so that at least one firewall 50 serves both to deny access such as surveillance by master M microprocessor 93 to an Internet 3 parallel processing (or multi-tasking) operation on slave S microprocessor 94 and to deny access to master M microprocessor 93 by Internet 3 (or other net) users of slave S microprocessor 94. At least one internal firewall 50 may be implemented by non-configurable hardware at the microchip level to provide protection against tampering with the internal firewall 50 by a PC 1 user, who has easier access to software or macro hardware such as PC motherboards to alter. PC 90 microchips may employ tamper-resistant construction or tamper-proof construction. As such, PC 90 microchips may be permanently locked by out-of-specification conditions or permanently destroyed by attempts at physical access.

Also, non-configurable hardware denying access from the network is the most immune to hacking from any outside source, including the Internet, and can therefore be used either for general protection or to protect an innermost kernel of the most confidential of personal files (such as passwords or financial data) and the most critical of operating system components, such as the system bios or access to file alternation.

At the same time, the FIG. 12 and earlier embodiments provide a solution to digital rights management by providing a highly safe environment for the owners of digital versions of audio, video, and software copyrighted material. Such copyrighted material as movies, television, music, and application or operating system software may be decrypted and controlled on the network user side of the PC 1 or PC 90, while the

PC 1 user is denied access to the decrypted digital version of the copyrighted material. However, the network user can make the material viewable to the PC 1 user, but not copyable, via the PC 1 and PC 90 microchip architecture shown in FIGS. 10A and 10C.

Any of the embodiments shown in FIGS. 12A and 12B can be combined with one or more of any of the preceding figures of this application to provide a useful improvement over the art.

FIG. 13 is like FIG. 20B of the '049 Application (and therefore also can be combined with FIGS. 11J and 11D, respectively), but show additionally that all microprocessors 30, 40, 93, and 94 of PC 1 or PC 90<sub>1</sub> can have a separate input/output communication link to a digital signal processor (DSP) or other transmission/reception connection component. The additional communications linkages are shown as 141, 142, 143, and 144, which connect to M<sub>1</sub>, S<sub>1</sub>, S<sub>21</sub>, and S<sub>22</sub>, respectively, and connect to the network, including the Internet 3, the WWW, the Grid, and equivalents or successors Like all preceding and subsequent figures, FIG. 13 is a schematic architectural plan of the new and unique components of the parallel processing system invention disclosed in this application and can represent either physical connections or virtual relationships independent of hardware. FIG. 13 shows an embodiment in which the additional linkages lead through the Internet 3 to microprocessors PC 90<sub>25-90<sub>28</sub></sub>.

The additional communications linkages 141, 142, 143, and 144, as well as the original linkages 111, 112, 113, and 114 of FIGS. 20A and 20B, may have a bandwidth sufficiently broad to at least avoid constraining the processing speed of microprocessors 30, 40, 93, and 94 connected to the linkages. The ultra high bandwidth of optical connections like optical fiber or omniguide or optical wireless may provide external connections between PC 1 and PC 90<sub>1</sub> microprocessors that are far greater than the internal electrical connections or buses of those microprocessors, for example, by a factor of 10, or 100, or 1000, which are already possible with optical fiber, or 1,000,000, which is possible with optical omniguide, which are not limited to a relatively smaller band of wavelengths using DWDM like optical fiber; future increases will be substantial since the well established rate of increase for optical bandwidth is much greater than that for microprocessor speed and electrical connections. Wireless optical antennas that are positioned on the exterior of houses, buildings, or mobile reception sites, instead of inside of glass or other windows, should significantly increase the number of optical wavelengths that can be sent or received by each of the wireless optical antennas; the entire connection is freespace optical wireless, which allows for greater dense wave division multiplexing (DWDM) and thereby greater bandwidth.

A major benefit of the embodiment shown in FIG. 13 is that PC 1 and PC 90<sub>1</sub> can function like the FIG. 9 embodiment to efficiently perform operations that are uncoupled, so that each microprocessor M<sub>1</sub>, S<sub>1</sub>-S<sub>34</sub> can operate independently without microprocessors M<sub>1</sub>, S<sub>1</sub>, and S<sub>21</sub>-S<sub>22</sub> being idled, as they may be in FIG. 13. Another benefit is that for tightly coupled parallel operations, microprocessors M<sub>1</sub>, S<sub>1</sub>, and S<sub>21</sub>-S<sub>22</sub> can have broad bandwidth connections with microprocessors 30, 40, 93, or 94 that are not located on PC 1 or PC 90<sub>1</sub>. Thus the embodiments shown in FIG. 13 provide an architecture that allows PC 1 or PC 90<sub>1</sub> the flexibility to function in parallel operations either like FIG. 13 embodiments or like the FIG. 9 embodiment of the '049 Application, depending on the type of parallel operation being performed. Studies indicate that single chip multiprocessors like PC 90<sub>1</sub> can also perform

uniprocessor operations with a speed like that of uniprocessor architectures like wide-issue superscalar or simultaneous multithreading.

Like FIG. 20B of the '049 application, the embodiment of FIG. 13 includes broad bandwidth connection to the Internet 3 by wired means such as optical connection by fiber optic cable or omniguide or optical wireless, although other wired or non-wired means can be used with benefit, and the use of DWDM or wideband CDMA is clearly advantageous. It should be noted that the architecture of the FIGS. 20 and 21 embodiments may be particularly advantageous with ultrawideband communication connections.

Another advantage of the embodiments shown in FIGS. 14A and 14B when functioning in the FIG. 9 (of the '049 Application) form of loosely coupled or uncoupled parallel processing or multitasking is that if PC 1 or PC 90<sub>1</sub> is functioning as a web server and typically uses only one microprocessor to do so, it can quickly add mirror web sites using one or more additional microprocessors to meet increasing volume of visits or other use of the web site. This replication of web sites on additional microprocessors in response to increasing load can also be done using the FIG. 11 form of tightly coupled parallel processing. PC 1 and PC 90<sub>1</sub> or any of their microprocessors 30, 40, 93, and 94 or other components can also serve as a switch or a router, including other associated hardware/software/firmware network components.

Any of the embodiments shown in FIG. 13 can be combined with one or more of any of the preceding figures of this application to provide a useful improvement over the art.

Binary tree configurations of microprocessors shown in FIGS. 11, and 13 can be laid out in 2D using an H-tree configuration, as shown in FIG. 21C of the '049 Application, and can be combined with one or more of any of the preceding figures of this application to provide a useful improvement over the art.

FIG. 14A shows a microprocessor PC 90<sub>1</sub> like that of FIG. 13, except that FIG. 14A shows the microprocessors 93 and 94 each connecting to an optical wired interconnection 99' such as thin mirrored hollow wire or omniguide or optical fiber (and other very broad bandwidth connections can be used); the interconnect can include a digital signal processor 89' employed with a microlaser 150, which can be tunable, and other components to transmit and receive digital data for microprocessors 93 and 94 into the optical wired interconnects 99' such as an omniguide using, for example, a specific wavelength of light for each separate channel of each separate microprocessor 93 and 94 utilizing dense wave division multiplexing (DWDM).

FIG. 14B shows an enlargement of the digital signal processor 89' with microlaser 150 with other transmission and reception components.

FIG. 14A shows a simple bus network connection architecture between the interconnect 99' and the microprocessors 93 and 94. However, since the interconnection 99' is optical and the bandwidth available is very broad, the optical connection 99' allows connections between microprocessors 93 and 94 in PC 90<sub>1</sub> that are functionally equivalent to those shown in FIG. 13 of the '049 Application, which includes a representation of physical connections. The interconnects between microprocessors 93 and 94 like FIG. 13 are shown within the omniguide 99' shown in FIG. 14A. In fact, the potential bandwidth of the optical interconnect 99' is so great that complete interconnection between all microprocessors 93 and 94 with PC 90<sub>1</sub> is possible, even for a much greater number of microprocessors either in a larger PC 90<sub>1</sub>, like FIG. 11C for example, or in other PC 90s, such as PC 90<sub>21-90<sub>24</sub></sub> and 90<sub>31-90<sub>316</sub></sub> in FIG. 13 connected to PC 90<sub>1</sub> through a network

such as the Internet 3, the WWW, or the Grid; consequently, any conventional network structure can be implemented. Consequently, the embodiment shown in FIG. 14A has the flexibility of those of FIG. 13 to function in parallel operations like either the FIGS. 20A-20B embodiments or like the FIG. 9 embodiment (both of the 0.049 Application), depending on the type of parallel operation to be performed, or the FIG. 11 embodiments.

It should be noted that the optical interconnect 99' shown in FIG. 14A can beneficially have a shape other than a thin wire or tube, such as an omniguide with any form or shape located above and connection to microlasers 150 at a suitable location such as on or near the upper surface of the microchip PC 90<sub>1</sub> located at least at each microprocessor 93 and 94 or connected thereto, for example; the optical interconnect 99' and microlasers 150 and associated transmission and reception components can be located elsewhere on the microchip PC 90<sub>1</sub> with benefit. An omniguide can take a waveform shape or rely exclusively on a mirrored (or semi-mirrored) surface or surfaces (or combination of both shape and mirrored surface) to guide lightwave signals such as propagated by a microlaser 150 substantially directly and/or by reflection. A relatively large optical interconnect 99' can enable freespace or wireless-like connections between microlasers 150; such an optical interconnect 99' can cover substantially the entire PC90 microchip or can connect multiple PC90 microchips and can connect one or more PC90 microchips to other PC components.

As shown in FIG. 14A, random access memory (RAM) 66 can be located on microchip PC 90<sub>1</sub> like in FIG. 11D and also can be connected directly or indirectly to the optical interconnect 99' (or use non-optical connections not shown), so that the microprocessors 93 and 94 and RAM 66 can communicate with a very broad bandwidth connection, including with RAM 66 and microprocessors 93 and 94 located off microchip PC 90<sub>1</sub> on the network including the Internet 3 and WWW. Any other components of the PC 90 microchip can be connected with the optical interconnect 99' and more than one such interconnect 99' can be used on the same PC 90 or other microchip. Microlasers 150 can include, for example, 5-to-20-micron-high (or other height) vertical cavity-surface-emitting lasers (VCSELs), which can beam down waveguides built into the PC90 microchip; alternatively, freespace optics can be employed; and lenses can be employed. Radio-frequency (RF) signals can also be used for similar interconnects 99'. Micro light emitting diodes (LEDs) can substitute for one or some or all of the microlasers 150 and either can be a transceiver (transmit and receive light signals).

FIG. 14C is a side cross section of the microchip PC 90<sub>1</sub> shown in FIG. 14A taken at hatched line 22C (which is abbreviated). FIG. 14C shows the location of the omniguide above the surface of the microprocessors 93 and 94 and RAM 66 and connecting them while also containing two or more microlasers 150 (associated DSP and other components not shown) proximate to each to contain the optical signal generated by the microlasers 150 so that the signal can be transmitted between microprocessors 93 and 94 and RAM 66 either directly or by being reflected off the mirrored (or semi-mirrored) surface of the omniguide 99', for example. Each of the microprocessors 93 and 94 (or 30 or 40) and RAM 66 (or any other memory component such as L1 cache or L2 cache, for example, or other microchip component) can have one or more microlasers 150 and each such microlaser 150 can distinguish itself from other microlasers 150 on the microchip (or off it) that also generate wavelength signals by using, for example, a distinct wavelength of light for data transmission and/or utilizing wave or dense wave division multiplexing.

FIG. 14A is a top view of the microchip PC 90<sub>1</sub>, which is a PC system on a microchip, any of which disclosed in this application can be also more generally any microchip with multiple processors. The microlasers 150 (and associated transmission and reception components such as DSP) that are associated with RAM (or parts of it) or other memory components can either provide data in response to direct inquiries or fetches made by a microprocessor 93 or 94 or can broadcast a continual stream of current data (continually updated and repeated in continuous cycle, for example) which is used by the microprocessor as needed.

Any of the embodiments shown in FIGS. 14A, 14B and 14C can be combined with one or more of any of the preceding figures of this application to provide a useful improvement over the art.

FIG. 15A shows multiple firewalls 50, a concept indicated earlier by the at least one firewall 50 discussed in FIG. 12D. FIG. 15A shows a PC1 or microchip 90 with a primary firewall 50 and additional interior firewalls 50<sup>1</sup>, 50<sup>2</sup>, and 50<sup>3</sup>, that are within primary firewall 50. As shown, interior firewall 50<sup>3</sup> is in the most protected position, since it is inside all the other firewalls, while the other interior firewalls 50<sup>2</sup>, and 50<sup>1</sup> are progressively less protected, since, for example, interior firewall 50<sup>1</sup> is protected from the outside network only by the primary firewall 50. As shown, progressively more protected positions can be created within the PC1 or microchip 90. The interior firewalls can also be arranged in any other way within the primary firewall 50. The interior firewalls can be used to separate user files from system files, for example, or to separate various hardware components from each other. In this manner, a number of compartments can be created within the PC1 or microchip 90 to more safely protect the software, hardware, and firmware of the PC1 or microchip 90, just as ships have a number of separate watertight compartments to protect against flooding and avoid sinking. Any of the primary or interior (or other inner firewalls discussed below) can be hardware, software, or firmware, or a combination, and can coexist in layers, so that a firewall 50, for example, may have a hardware firewall, a software firewall, and a firmware firewall, either as independent units or as integrated components. W<sup>3</sup> in FIG. 15A and subsequent Figures denotes the World Wide Web.

FIG. 15B shows another embodiment of compartments created by inner firewalls within a PC1 or microchip 90. Primary firewall 50 and interior firewall 50<sup>1</sup> are like FIG. 15A, but interior firewalls 50<sup>2</sup>, 50<sup>3</sup>, and 50<sup>4</sup> are shown perpendicular to firewalls 50 and 50<sup>1</sup> (just to illustrate in a simplified schematic way, which may be different in an actual embodiment). In this way, an upper row of compartments U<sup>1</sup> and U<sup>2</sup> can be used, for example, to bring from the network files which are first authenticated and then enter into the U<sup>1</sup> compartment, are decrypted, and undergo a security evaluation, such as by virus scan, before transfer to the most secure compartment U<sup>2</sup>. Any operations could potentially occur in any compartment, depending on the level of security desired by the user (by over-ride) for example, but an advantageous default system would allow for files with the highest levels of authentication, encryption, and other security evaluations to be allowed into the most secure compartments.

Similarly, operating system files can also be authenticated and brought from the network side of the PC1 or microchip 90 into compartment O<sup>1</sup> for decryption and security evaluation or other use, and then finally transferred into the most secure compartment O<sup>2</sup>. Again, similarly, a row of compartments can be used for separating hardware, such as a master micro-

processor 30 or 93 being located in compartment M<sup>1</sup> and a remote controller 31, for example, located in compartment M<sup>2</sup>.

Also, additional inner firewalls 50<sup>22</sup>, 50<sup>33</sup>, and 50<sup>44</sup> can be located outside the primary firewall 50, but within the network portion of the PCI or microchip 90, to separate user files in compartment U from operating system files in compartment O from hardware such as a slave microprocessor in compartment S on the network side. In the example shown, an additional row is shown for hardware, including a hard drive in a compartment HD on the network side, a hard drive in compartment HD<sup>1</sup> on the PCI or microchip 90 user's side, and flash memory (such as system bios 88) in compartment F<sup>2</sup>. Each microprocessor 30, 40, 93, or 94 can have its own compartment in a manner like that shown in FIG. 15B, as can associated memory or any other hardware component.

FIG. 15C shows an inner firewall 50 embodiment similar to FIG. 15B, but FIG. 15C shows that any file or set of files, such as operating files O or user data files U or application files A, can have its own inner firewall 50<sup>O</sup> or 50<sup>U</sup> or 50<sup>A</sup>. Similarly, any hardware component, such as hard drive HD, also can have its own inner firewall 50<sup>HD</sup>. Additionally, more than one file or set of files or hardware components can be grouped together within an inner firewall, such as 50<sup>S</sup> shown in FIG. 15C.

FIGS. 15D and 15E show operating system files O or application files A like those shown in FIG. 15C, but organized differently in discrete layers, each separate grouping of the operating or application files having a separate firewall 50 (and optionally with as well as a PCI or PC90 firewall shown in earlier Figures), so that the firewall structure is like that of an onion. The operating system files O or application files A can have a parallel structure, with an innermost kernel operating system or application file located in the center, with additional features in other files in subsequent layers, from the simplest to the most complex and from the most secure and trusted to the least secure and trusted.

Using this structure, as shown in FIG. 15D, an innermost operating system core O<sup>1</sup> may be firmware stored in a read-only memory (ROM), located in a microchip for quick access, so that a simplest version operating system with all core features can be protected absolutely from alteration and can be available almost immediately, without lengthy boot up procedures required by loading the operating system from a hard drive, for example. The core operating system O<sup>1</sup> can include a core of the system BIOS or of the operating system kernel, for example; it would be advantageous for this core to be capable of independent operation, not dependent on components in other levels to operate at the basic core level (similarly, other levels can advantageously be independent of higher levels).

A secondary operating system O<sup>2</sup> can be software located advantageously on flash or other microchip non-volatile memory such as magnetic (or less advantageously, a hard drive or other mechanical storage media) and can consist of additional features that are more optional, such as those not always used in every session, or features that require updating, changing, or improving, such features coming from trusted sources located on a network, such as the Internet or the Web; additional portions of or upgrades to the system BIOS and the operating system kernel can be located in O<sup>2</sup>, for example.

A third level operating system O<sup>3</sup> located, for example, on a hard drive, can consist of additional software features that are used only occasionally and are more optional, and can be loaded as needed by a user into DRAM or magnetic memory microchip for execution, for example. Operating systems O<sup>2</sup>

and O<sup>3</sup> can include, for example, the most recent upgrades from a known and trusted source, such as a commercial software vendor or open source software developer, that are downloaded from a network, including the Internet and the Web, or loaded from conventional memory media like CD or floppy diskette. All three levels of such operating systems O<sup>1</sup>, O<sup>2</sup>, and O<sup>3</sup> together can constitute, for example, roughly the equivalent of a conventional PC operating system typical in the year 2000.

A fourth level operating system O<sup>4</sup>, for example, can consist of special use or single use operating system add-ons, especially software coming from untrusted or unauthenticated sources on a network, such as the Internet or the Web.

For example, the graphical interface of the operating system can be in 2D only at the O<sup>1</sup> level, in 3D at the O<sup>2</sup> level, rendering at the O<sup>3</sup> level, and animation in the O<sup>4</sup> level; additionally, a standard format can be maintained in the O<sup>1</sup> and O<sup>2</sup> levels, with user or vendor customization at the O<sup>3</sup> level.

As shown in FIG. 15E, application files such as A<sup>1</sup>, A<sup>2</sup>, A<sup>3</sup>, and A<sup>4</sup> can be structured the same way as operating system files O in FIG. 15D and with the same layered approach to firewalls 50 as in FIG. 15D. Typical application software of the year 2000 can be restructured in this manner.

The kernel operating system files O<sup>1</sup> and O<sup>2</sup>, as well as kernel application files A<sup>1</sup> and A<sup>2</sup> can be located in any personal computer PCI or PC90, including at the level of an appliance including the simplest device, advantageously in ROM and in non-volatile read/write memory such as Flash (or magnetic such as MRAM, or ovonic memory) microchips, for example, as described in FIGS. 15D and 15E above. Inclusion of wireless connection capability is advantageous, as is the use of DWDM.

An advantage of the file and firewall structures shown in FIGS. 15D and 15E is that a system crash or file corruption should never occur at the simple and unalterable level O<sup>1</sup> or A<sup>1</sup> and any level above O<sup>1</sup> or A<sup>1</sup> can be recovered at a lower level, specifically the highest level at which there is a stable system or uncorrupted data. For example, a word processing application program can have the most basic functions of a typewriter (i.e. storing alphanumeric, punctuation, spacing, and paragraph structure data) stored on a ROM microchip in A<sup>1</sup> and related user files (i.e. such as a word document) on U<sup>2</sup>. Insertion of a digital video file into a word document can be handled at the A<sup>3</sup> level and insertion of a downloaded special effect at the A<sup>4</sup> level. In this example, a crash caused by the insertion at the least secure and most complex A<sup>4</sup> level would not disturb the word document located at the U<sup>2</sup> or U<sup>3</sup> level. Rebooting and/or recovery can be automatic when detected by the operating system or at the option of the user.

Thus, FIGS. 15A-15E illustrate embodiments wherein a PCI or microchip 90 includes a hierarchy of firewalls. In the context of the present invention, firewalls may be structured to allow varying degrees of access from the network side of PCI or microchip 90. As discussed above, ROM may totally deny access from the network side, effectively creating an innermost firewall. Hardware, software, firmware, or combinations thereof may be structured to deny or allow a predetermined maximum level of access from the network side, effectively creating outer firewalls. Similarly, intermediate firewalls effectively may be created.

The embodiments of FIGS. 15A-15E, as well as earlier FIGS. 12A-12D and earlier embodiments, provide a solution to digital rights management by providing a highly safe environment for the owners of digital versions of audio, video, and software copyrighted material. Such copyrighted material as movies, television, music, and application or operating

system software may be decrypted and controlled on the network user side of the PC 1 or PC 90, while the PC 1 user is denied access to the decrypted digital version of the copyrighted material. However, the network user can make the material viewable to the PC 1 user, but not copyable, via the PC 1 and PC 90 microchip architecture shown in FIGS. 10A and 10C. For example, a copyrighted movie or music album may be a file that is associated with control and other software; all files located on one or more specific hardware components may be grouped together within an inner firewall, such as 50<sup>S</sup> shown in FIG. 15C.

Additional security for copyright owners may be provided by using a digital signal processor (DSP), and/or analog and/or other components grouped within the inner firewall 50<sup>S</sup> to convert network user selected decrypted digital files into analog files before they are transmitted off the PC 90 microchip, so that only an analog signal exits the PC 90 microchip for viewing or listening by the PC 1 user. As such, direct digital copying by the PC 1 user of copyrighted digital files provided over the Internet is prevented.

Any of the embodiments shown in FIGS. 15A-15E can be combined with one or more of any of the preceding figures of this application to provide a useful improvement over the art.

Additionally, an inner firewall can divide any hardware component into a separate network side compartment and a separate firewall protected side compartment. For example, a hard drive 61 can have a controller 61' that is divided into two compartments, HD and HD<sup>1</sup>, as above. As shown in FIG. 24 of the '049 Application, the user side HD<sup>1</sup> compartment of the controller 61' can have a read capability controller r and a write capability controller w, while the network side HD compartment can be limited to a read capability controller r only. The user side HD<sup>1</sup> compartment controller can be, for example, used to control only the upper surface of the hard drive 61 platters, while the network side HD compartment controller can be used to control only the lower surface of the hard drive 61 platters, so that a single hard drive can effectively serve a dual role as both a network-accessible hard drive and a user-accessible hard drive, while maintaining a firewall 50 between them. Additionally, the network side HD controller can optionally have a write capability also, which can be preemptively turned on or off by the PC1 or microchip 90 user. Other relative allocations between network and user of the HD 61 platters can be made and can be configurable by the user or system administrator or not configurable.

Similarly, CD drives 63 or DVD drives 64 (read only or read/write) can have a controller 63' or 64' like that of the HD controller 61' above that is divided by a firewall 50, so that some laser beams are under network control and other laser beams are under user control, like the above hard drives. Floppy disk drives, "Zip" drives, and other removable disk or diskette drives can similarly be divided by a firewall 50 so that there is a physical user portion of the disk or diskette and a physical network portion of the disk or diskette, both either fixed or configurable by a user or system administrator or other authorized source. Memory microchips such as RAM or Flash or other can also be divided into network and user sides in a similar manner.

The use of volatile memory on the network side of the PC1 or microchip 90 is particularly useful in eliminating viruses and other security problems originating from the network side, such as malicious hackers on the Internet. When the network side of the firewall 50 of the PC1 or microchip 90 is returned to its user (preemptively or otherwise), volatile memory like random access memory (RAM) such as DRAM on the network side can first be erased. For example, volatile memory can be purged by momentarily interrupting power to

the network side of the PC1 or microchip 90, thereby erasing all network data so that no network data is retained when the user regains control of the network side of the PC1 or microchip 90 for the user's use, except at the user's option; other conventional means may be employed. Of course, when the user is specifically using the network side, for example, for Web browsing, the operating system or the user can selectively save network side files or transfer them to the user side.

On the network side, non-volatile memory like Flash, MRAM, and ovonic memory with network data must be overwritten to obtain the same erasure-type protection, which can be a disadvantage if it takes much more time. Moreover, for relatively large storage media, such as CD-RW or DVD-RW with write-once capability, network data writing must be tracked to be effectively erased. Any new network file on non-volatile memory with only a write-once capability can be erased by overwriting all "0's" to "1's", so that, for example, the network data written on a CD-RW or DVD-RW would be converted to all "1's" or "pits" (no unpitted writing surface within the network data sector, permanently overwriting the file); optionally, the operating system or the user can selectively save network side files or transfer them to the user side, or vice versa. There is a disadvantage to using Flash memory, since repeated overwriting will eventually degrade it.

FIGS. 16A-16D show the use for security of power interruption or data overwrite of volatile memory like DRAM and non-volatile memory like Flash or MRAM (or ovonics), respectively, of the network portion (N) of a personal computer PC1 or system on a microchip PC90; the network (N) portion being created within a PC1 or PC90 by a firewall 50 (as described above in previous figures) and including resources that, when idled by a user, can be used by the network, including the Internet (I) or the World Wide Web. Such use is to prevent the unplanned or approved mixture of user and network files by either files being retained in the "swing space" (N) during the transition from use by a network user to use by the PC1/PC90 user or vice versa.

As shown in FIG. 16A and FIG. 16C, when the network portion (N) of the PC1 personal computer or PC90 microchip is idled by a user, for example, power is interrupted to volatile memory like DRAM and/or data is overwritten to files in non-volatile memory like Flash or MRAM (or ovonics), so that no files exist in the network portion (N) after such interruption or overwriting.

After the step shown in FIGS. 16A and 16C, the network portion (N) can be used safely from a security viewpoint by a user from the network, including the Internet and the World Wide Web (and potentially including other network resources), as shown in FIG. 16B, or by the PC1/PC90 user, as shown in FIG. 16D, potentially including other resources from the user portion (U) of the PC1 or PC90. As noted earlier, the FIG. 16 approach can advantageously be used as an additional feature to other conventional security measures.

Any of the embodiments shown in FIGS. 16A-16D can be combined with one or more of any of the preceding figures of this application to provide a useful improvement over the art.

The PC 90 microchip as previously described, or a personal computer PC 1 (or any microchip, including a special or general purpose microprocessor on a microchip, alone or including one or more other system components as previously described) may include one or more photovoltaic cells 201, as are well known in the art. The photovoltaic cells 201 may be located on the PC 90 microchip or located near the PC 90 microchip, such as adjoining it or adjacent to it, or located less near, such as in the PC 90 microchip user's home, office, or vehicle, either inside or outside, or may be located more remotely.

FIG. 17A shows one or more photovoltaic cells **201** located on a PC **90** microchip. The photovoltaic cells **201** may use electromagnetic radiation, such as visible light, as a power source that is directed to the cells **201** by an optical waveguide **202**, which may include a size that is sufficient to allow the cells **201** to generate electrical power at maximum output level or at a most efficient level. In addition, visible light in freespace (without a waveguide **202**) may also serve as a power source and can be directed by the use of one or more lenses **204**.

FIG. 17B shows a single microchip **200** including both a PC **90** and one or more photovoltaic cells **201**. FIG. 17B shows a top view of a multi-layer microchip having one or more photovoltaic cells **201** on one side of a microchip **200**, with a PC **90** on the other side of the microchip **200**, as shown in FIG. 17C in a bottom view of the same microchip as FIG. 17B. Besides being integrated on the same microchip **200**, the photovoltaic cells **201** may be located separately from the PC **90** microchip, and the two separate elements may be joined or adjoining.

A light source for the photovoltaic cells **201** can be direct or indirect and can be sunlight or artificial light, including light from a laser, or a combination, and can be optionally focused by a lens **204**. The light may be coherent with one or more discrete frequencies, such as from a laser, or incoherent with many frequencies. The artificial light may be generated by well known conventional means that are conventionally powered by electricity distributed by the existing electrical power grid, as is well known in the art.

A single photovoltaic cell or a number of cells **201** may power each component on the PC **90** microchip, such as the master microprocessor **93** or slave microprocessors **94**, DRAM or MRAM, Flash memory, DSP, or laser **150**, or any of the other components previously described. The photovoltaic cells **201** may be connected to one or more batteries. The photovoltaic cells **201** can be located remotely as a separate unit, such as on the PC **90** microchip user's roof at home, car, or office, so that the cells **201** provide general local power or power dedicated to the PC **90** microchip and/or associated components. The PC **90** microchip may be a network server, router, or switch, so that any network component can be powered by photovoltaic cells **201**, including the Internet, an Intranet, or the World Wide Web.

The FIG. 17A-17C embodiments advantageously eliminate the need for a microchip, such as the PC **90** microchip, to have a wired connection **99** that typically provides power or data or both, but which also provides a connection means for the entry of electromagnetic flux, which can impair or destroy the functioning of the PC **90** microchip. The embodiments shown rely on light, which does not transmit electromagnetic flux, for power and data.

FIG. 18A shows a single microchip **200**, combining a PC **90** microchip (or any microchip, including a special or general purpose microprocessor on a microchip, alone or including one or more other system components as previously described) and one or more photovoltaic cells **201**, that is substantially surrounded by a Faraday Cage **300**, such as is well known in the art, that is optimized to shield against magnetic flux, including high frequency flux (and may include shielding against electric flux). Faraday Cage **300** may be constructed of a mesh structure, or may also be a continuous structure without holes, which has an advantage of preventing entry by very high frequency electromagnetic flux, and may incorporate other microchip structures, such as a heat sink **301**.

FIG. 18B shows separate PC **90** microchip and one or more photovoltaic cells **201**; the two separate components are con-

ected by a wire **99**, and all three components are substantially surrounded by a Faraday Cage **300**, also known as a Faraday Shield or Screen.

FIG. 18C shows the same components as FIG. 18B, but shows each component substantially surrounded by a separate Faraday Cage **300**, all of which may be connected. For portable handheld wireless devices, the ground for the Faraday Cage **300** may be the user's body.

As shown in FIG. 18D, the PC **90** microchip may be located in a housing for any of the PC's described previously, such as a case of a laptop personal computer **401** or a PC cell phone **402**, which may also have a separate Faraday Cage **300**, so that the PC **90** microchip is substantially surrounded by more than one Faraday Cage **300**. The inner Faraday Cage **300** surrounding the PC **90** microchip may be optimized to shield against specific frequencies of magnetic flux, such as high frequency flux in the microwave range, which may be assisted by the relatively smaller size of the PC **90** microchip (compared to its housing). FIG. 18D shows an inner Faraday Cage **300** surrounding only a portion, the PC **90**, of a microchip such as the combined microchip **200**.

As shown in FIGS. 18E and 18F, the PC **90** microchip can be separate from the photovoltaic cell or cells **201** and can be joined by a wired connection **99**.

As shown in FIG. 18E, an inner Faraday Cage **300** may surround only a portion of a PC **90** microchip, such as a Magnetic Random Access Memory (MRAM) component.

FIG. 18F shows Faraday Cage **300** that surrounds only a portion of one or more photovoltaic cells **201**, such as a part conducting an electrical current flow directly to the PC **90** microchip.

The PC **90** microchip may also be powered by one or more fuel cells **211** or one or more batteries (each with one or more cells) **221** or any combination of such batteries **221**, fuel cells **211**, or photovoltaic cells **201**. As shown in FIGS. 18E and 18F, the PC **90** microchip is typically separate from a fuel cell or cells **211** or batteries **221** and can be joined by a wired connection **99**, as shown, as is the case with a photovoltaic cell or cells **201**. A wired connection **99** can be configured to protect the PC **90** microchip from electromagnetic flux through the use of RF traps or Ferrite grommets or beads **212** on the wire or cable connection **99**.

By providing power without an external wired connection **99**, both fuel cells **211** and batteries **221** isolate the PC **90** microchip from a power grid that can transmit electromagnetic flux, but to do so a battery or batteries **221** can be configured to provide connection to the power grid only intermittently when charging is required.

FIG. 18G shows a microchip, such as a PC **90** microchip, surrounded by a Faraday Cage **300** but without including a photovoltaic cell **201** shown in FIGS. 18A-18F.

FIG. 18H shows a PC housing such as a laptop PC **401** or PC cell phone **402** including a PC **90** microchip and separate Faraday Cages **300** surrounding both the microchip and housing. Also shown is an antenna **499** (or antennas) for wireless communication that can be separated from the Faraday Cage **300** to protect the electrical components of the PC by an RF trap or Ferrite grommets or beads **212**. The antenna **499** can project externally from the PC housing or be located internally in the PC housing, such as in the screen housing of a laptop PC **401**. In an exemplary implementation, the antenna **499** is located outside of at least one Faraday Cage **300**.

Any of the embodiments shown in FIGS. 17A-17C and 18A-18H may be combined with one or more other embodiments shown in those figures or in preceding FIGS. 1-16 and described herein.

FIG. 19 shows a silicon wafer 500 used to make microchips. The largest wafers 500 in current use are 300 mm (12 inches) in diameter and can contain as many as 13 billion transistors. Current state of the art in microchip fabrication is 0.13 micron process technology and the next process will be measured in nanometers (90 nm). As shown in FIG. 19, microchips 501 are separated by an edge portion 502. A microchip 501 can be a PC 90 microchip.

FIG. 20A shows a top view of a microchip 501 surrounded by adjoining portions of adjoining microchips 501 in a section of the silicon wafer 500. The microchip 501 is bounded by edge portions 502. Although the current state of the art in microchip fabrication on a silicon wafer is to use only one process on a wafer, embodiments of the invention use two or more fabrication processes on a single wafer 500.

As shown in the example of FIG. 20A, one process can be located on one section 511 on the microchip 501, while a second process can be located on a second section 521 of the microchip 501. A third process can be located on a third section 531 of the microchip 501; additional processes can also be located on other sections of the microchip 501.

The processes can be completely separate while at least sharing the common silicon wafer 500 base, and the processes can occur at different fabrication facilities, including those owned by different manufacturers. Alternatively, two or more separate processes may have common sub-processes that can be integrated, i.e., performed at the same time. Sections of the microchip 501 that are not undergoing a process can be protected from that process by a protective coating that is unaffected by that process and removed after that process. There can be one or more temporary protective coatings, which can remain on for more than one process.

The separate sections of the separate fabrication processes of the microchip 501 can be in any shape or pattern of the microchip. As shown in the FIG. 20A example, one or more separate processes can be located on adjoining portions of adjoining microchips. For example, as shown in FIG. 20A, section 521 is located on the lower portion of one row of microchips 501 and on the upper portion of the adjoining row of microchips 501, which would be positioned upside down of the wafer 500, so that the contiguous area of the section 521 process is maximized. Similarly, section 531 is shown in the example located on the lower portion of the adjoining row of microchips 501 and on the upper portion of the middle row of microchips 501. Alternatively, all of the microchips 501 of the wafer 500 can be positioned upright on the wafer.

Embodiments of the invention include any fabrication process of a silicon wafer 500 and can include wafers made of other materials suitable for microelectronic devices, such as gallium arsenide. The fabrication processes in current widespread use are generally CMOS (complementary metal-oxide semiconductor), but can be bipolar or other. The separate processes (and separate sections 511, 521, and 531 shown in FIG. 29A) can be for general purpose microprocessor (including one or more cores), memory (DRAM or non-volatile such as Flash or MRAM or ovonic), analog (including radio and/or laser), digital signal processing (DSP), micro-electromechanical system (MEMS), field programmable gate arrays (FPGA), graphic processing unit (GPU), microprocessor chipset, and others.

Embodiments of the invention facilitate a "system on a chip" (SoC), such as the earlier described PC 90 microchip, by allowing most or all of the micro components of a PC to be located on a single microchip. Even the consolidation of only two microchips into a single microchip provides a significant increase in processing speed and reduced power consumption. The silicon die becomes the motherboard for all the

micro components of the PC, leaving only the macro components like battery, power supply, and input/output (I/O) connections to be located on the printed circuit motherboard. The result is ultra-large-scale-integration.

FIG. 20B shows a top view of the microchip 501 embodiment of FIG. 20A after the die has been separated from the silicon wafer 500 and positioned in a microchip package 503.

The fabrication processes illustrated in FIGS. 20A-20B can include material such as silicon germanium, gallium arsenide, indium phosphide and others used, for example, as deposits on silicon. Besides using different materials in different sections of the microchip, different size processes can be used in different microchip sections, such as a 0.13 micron process on section 511 and a 0.18 micron process on section 521 in the FIG. 29A example. All or parts of the microchip 501 can be synchronous or asynchronous. Both different size and different material processes can be combined on different sections of the microchip 501.

Although the maximum increase in speed and decrease in power consumption can be achieved by putting all micro or nano components on a single "system on a chip," such as for a PC, even a minimal combination of just two different micro or nano components of a single microchip 501 can yield a very significant increase in speed and decrease in power consumption. To take a very simple example, a silicon wafer 500 can have 256 MB of DRAM manufactured onto a section 531 of the microchips 502 located on the wafer by one factory; when that DRAM process is completed, a second factory can add a general purpose CPU like a Pentium 4 to a second section 511 of the microchips 501 on the silicon wafer 500. Such an approach allows direct communication between microprocessor and DRAM on the microchip 501 for much greater speed and reduced power. Since 256 MB DRAM is an inexpensive commodity product currently, especially if purchased as wafers 500, there would be little or no increase in the production time of the microprocessor.

FIG. 21A illustrates an embodiment of the invention, which is an alternative method of uniting separate fabrication processes on the same microchip 501. Sections 501<sup>1</sup>, 501<sup>2</sup>, and 501<sup>3</sup> of FIG. 21A correspond to sections 511, 521, and 531 of FIGS. 20A & 20B in that both sets of sections represent three separate processes, but in FIG. 21A each section is a separate die cut from a wafer 500 and all three sections are united in a single package 503. The section dies 501<sup>1</sup>, 501<sup>2</sup>, and 501<sup>3</sup> can be held together by the chip package 503 or can be glued together, or a combination of the two in parts or the whole. In addition, the section dies can be assembled into a chip package 503 or the package can be assembled around the dies or a combination of both partially or completely.

The separate process dies illustrated in the FIG. 21A example may be assembled with the surface that the process is on in each die being substantially level with each other, so that both process surfaces of the dies form a plane that is substantially flat. The edges of the dies are configured so adjoining dies fit together as closely as possible, as shown in FIG. 21A at 502<sup>2</sup> and 502<sup>3</sup>.

The circuits of dies 501<sup>1</sup>, 501<sup>2</sup>, and 501<sup>3</sup> are connected at their edges 502<sup>3</sup> and 502<sup>2</sup> by interconnect lines 580 that can be widened as shown in 581 of FIG. 21B, which shows a portion of die edge 502<sup>3</sup> and 502<sup>2</sup> in an enlarged view. A process can be added in the area 591 overlapping the edges of the dies at 502<sup>3</sup> and 502<sup>2</sup> bounded by lines 590; in that process interconnect lines 580 of the two separate dies can be connected by laying down connections at 582 that connect to the enlarged portions 581 of the interconnect lines 580, as illustrated in FIG. 21B.

FIG. 21C shows that the die edges 502<sup>3</sup> and 502<sup>2</sup> can have any shape or pattern, not just a straight line shown above in FIGS. 21A & 21B.

FIG. 22 shows a combination of the embodiments shown in FIGS. 20 and 21. Microchip 501 as shown in FIG. 20 is shown assembled with separate dies 501<sup>1</sup>, 501<sup>2</sup>, and 501<sup>3</sup> into a microchip package 503, with edges between dies at 502<sup>1</sup>, 502<sup>2</sup>, 502<sup>3</sup>, and 502<sup>23</sup>, which could include a connection process such as the example shown in FIG. 21B.

The microchip 501 dies shown in FIGS. 20-22 can be packaged using FCPGA (flip-chip pin grid array), FCBGA (flip-chip ball grid array), BBUL (bumpless build-up layer) or other technology.

Any of the embodiments shown in FIGS. 19, 20A-20B, 21A-21C, and 22 can be combined with one or more other embodiments shown in those figures or in the preceding FIGS. 1-18 and described herein.

FIGS. 23A-23H are new inventions based on FIGS. 18A-27H of this application, which are FIGS. 27A-27H of U.S. application Ser. No. 10/802,049 filed Mar. 17, 2004 and published on Oct. 28, 2004, as Pub. No. US 2004/0215931 A1 and U.S. application Ser. No. 10/684,657 filed Oct. 15, 2003 and published on Aug. 18, 2005, as Pub. No. US 2005/0180095 A1, both of which applications are hereby incorporated by reference herein for completeness of disclosure.

FIGS. 23A-23H are example new embodiments based on the FIG. 7B example; they show examples of the applicant's inventions involving one or more Faraday Cages surrounding various combinations of semiconductor microchips, photovoltaic cells, and/or other micro and/or nano devices with the applicant's internal sipe inventions 510/511/513. In the exemplary embodiments shown, the Faraday Cages 300 coincide with the outer compartment 500, which forms a surface of the sipe 505 (as previously defined) which can partially or completely surround the PC 90 microchip and/or photovoltaic cell 201 and/or fuel cell 211 and/or battery 221; any one or more of which (90/201/211/221) can be connected by wire 99, which can also be protected by Faraday Cage 300 so that all components are protected; and one or more Faraday Cages 300 and or internal sipes 505 can be inside a Faraday Cage 300 and/or internal sipe 505 so as to provide additional protection, including of one or more individual components, as shown in several useful examples in the FIGS. 23A-23H.

Heat sink 301 or other microchip cooling device can be augmented or replaced by a cooling media 506, which can for example circulate by convection alone within the sipe 505 as shown in FIG. 23G for example or can be allowed to circulate away from the microchip or other micro or nano device to a heat sink in another location, for example, including by circulation powered by a pump, for example, or other powered means. One or more attachments 503 can provide external connection from the microchip/cell 200 or other component like fuel cell 211 or battery 221 to the outer compartment 500 and/or Faraday Cage 300 and then to other external connections, such as a wire 99 as shown in FIG. 23C or an antenna 499 as shown in FIG. 23H; as shown in the FIG. 23D example, one or more attachments 503, which can be one or more conventional pins, can connect a microchip PC 90 and/or other component with an internal Faraday Cage 300. Advantageous combinations of the FIGS. 23A-23H embodiments can be made with embodiments shown in FIGS. 24A-24C, 25A-25B and 26A-26B, as well as with previous FIGS. 1-22.

FIGS. 24A and 25A-25B are based on FIGS. 28 and 29A-29B of U.S. application Ser. No. 10/684,657 filed Oct. 15, 2003 and published on Aug. 18, 2005, as Pub. No. US 2005/0180095 A1, which was above incorporated by reference herein for completeness of disclosure.

FIG. 24A is a top view of a semiconductor wafer 1500, of which 300 mm. is a current example using a 90 nanometer process, made of silicon, gallium arsenide, or any other suitable semiconductor materials in current use or future equivalents. The wafer 1500 contains a multitude of microchips 1501 with each microchip 1501 including, for example, 1 or more core microprocessors 93 or 94, including at least 2 or 4 or 8 or 16 or 32 or 64 or 128 or 256 or 512 or 1028 or more cores. But instead of separating the microchips 1501 into separate dies in the conventional process along lines 1502, the entire semiconductor wafer 1500 of any size (including smaller than 300 mm) is used essentially intact (that is, undiced into dies) as a computer (or in one example embodiment, the wafer 1500 can be virtually entire and intact, excluding deactivated or disconnected incomplete microchips 1501 located around the periphery of a circular wafer and microchips 1501 with manufacturing defects or other damage, such as failure during use, which can remain inactively on the wafer); instead of separating along lines 1502, interconnects 1505 of any length or configuration can be added to the printed circuit architecture to connect the microchips 1501 to other microchips 1501 and/or other components on the wafer 1500 or external to it, using any interconnection means or architecture known in the art.

The microchips 1501 on the wafer 1500 can for example each be a complete personal computer (PC 90) system on a chip (SoC), including for example microprocessors, random access memory, radio and/or optical communication components, and other operational components necessary for each microchip 1501 to be capable of functioning as a fully independent PC 90 unit on the semiconductor wafer 1500. Each PC 90 microchip 1501 on the wafer 1500 is in effect a stand-alone unit capable of operating independent of any other PC 90 microchip 1501 on the wafer; this means that operations of PC 90 microchips 1501 occurring on the wafer 1500 can occur asynchronously, such as some or all of the PC 90 microchips 1501 on a wafer can operate together as a cluster of personal computers, as is conventional in the art, and can also include other personal computers in the cluster that are not on the wafer 1500. The semiconductor wafer 1500 can be used with other conventional interface devices for power and data communication, including wireless such as radio and/or optic (See FIG. 14, for example), and/or wired such as fiber optic and/or electric; such connections can reduce or eliminate the need for interconnections between the PC 90 microchips 1501 or pins connecting a wafer 1500, for example, to a motherboard (not shown). One or more PC 90 microchips 1501 can also include these connections, and all can include wireless communication capability such as a radio or optic device, so that even cluster operations between PC microchips 1501 on a wafer 1500 can occur completely on wafer 1500, obviating the need for pins and interconnects.

Alternatively, more than one semiconductor wafer 1500 can be stacked in vertical layers, for example, with wafer 1500 #1 including microprocessors or cores; wafer 1500 #2 including random access memory or RAM such as DRAM; and wafer 1500 #3 including other components, as shown in the FIG. 24B example, which is similar to FIG. 7B of this application. The wafers stacked can be entire wafers as shown, or portions of wafers (such as FIG. 24C below), or one or more entire wafers with one or more portions of wafers or dies or other components.

By reducing or eliminating the need to go "off microchip" or off wafer in this case to complete computation operations, the applicant's invention provides huge savings in terms of speed and energy efficiency.



FIG. 24A also shows an example of the semiconductor wafer 1500 including one or more of the applicant's 510 or 511 or 513 internal sipe invention, with an outer compartment 500 with a sipe 505. In addition, FIG. 24A shows an example of the semiconductor wafer 1500 including one (or potentially more) Faraday Cage 300 surrounding the semiconductor wafer 1500. Moreover, FIG. 24A shows an example embodiment wherein both one or more of the internal siped inventions 510/511/513 and one or more of the Faraday Cages 300 can be used with the same semiconductor wafer 1500. Finally, FIG. 24A shows an example wherein one or more of the outer compartment 500 of the internal siped invention coincide with one or more of the Faraday Cages 300. Each of the four example embodiments described above in this paragraph can be used independently from each other or in any combination, including all four together as shown in FIG. 24A.

FIG. 24B shows a side cross section of vertically stacked semiconductor wafers 1500, which have interconnects or vias 1504 between facing proximate surfaces of the wafers. FIG. 24B shows a three wafer example embodiment; two or more wafers can be stacked in any manner, including with each directly aligned on top of one another, as shown, or partially overlapping in any manner. Two or more of the wafers 1500 can contact directly as shown or a non-wafer layer can be between them.

As with the example embodiments shown in FIG. 24A, FIG. 24B shows those stacked wafers 1500 including one or more of the applicant's 510 or 511 or 513 internal sipe invention, with an outer compartment 500 with a sipe 505. In addition, FIG. 24A shows an example of the stacked semiconductor wafers 1500 including one or more Faraday Cage 300 surrounding the semiconductor wafer 1500. Moreover, FIG. 24A shows an example embodiment wherein both one or more of the internal siped inventions 510/511/513 and one or more of the Faraday Cages 300 can be used with the same stacked semiconductor wafers 1500. Finally, FIG. 24A shows an example wherein one or more of the outer compartment 500 of the internal siped invention coincide with one or more of the Faraday Cages 300 surrounding the stacked wafers 1500. Each of the four example embodiments described above in this paragraph can be used independently from each other or in any combination, including all four together as shown in FIG. 24B.

FIG. 24C is another top view of a circular wafer 1500, but subdivided into smaller components, such as half sections at the upper example and quarter sections in the lower sections. Other smaller component embodiments, including other non-rectangular embodiments can be used beneficially. Advantageous combinations of the FIGS. 24A-24C embodiments with embodiments shown in FIGS. 23A-23H can also be made, as well as with FIGS. 25A-25B and 26A-26B, as well as with previous FIGS. 1-22.

The invention examples shown in FIGS. 24A-24B can be used as stand-alone computers or as networked computers or as components of a computer. As noted above, sipe media 506 can also be a coolant, which can circulate to a location outside the outer compartment 500 (not shown) or be enclosed within the 300/500 structure (shown in FIG. 24B partially filling sipe 505 as one example and completely filling sipe 505 as another example (not shown)).

FIGS. 25A-25B are modifications of FIGS. 20A and 20B of this application (which are FIGS. 29A-29B of the '657 application incorporated by reference herein above). FIG. 25A shows a top view of PC 90 microchips 1501 on a portion of the semiconductor wafer 1500, including interconnects

1505 between the microchips 1501, and the microchips 1501 being bounded by edge portions 1502.

FIG. 25B shows a microchip 1501 as a separated die in a package 1503 including the applicant's internal sipe inventions 510/511/513 and the Faraday Cage 300. Advantageous combinations of the FIGS. 25A-25B embodiments can be made with embodiments shown in FIGS. 23A-23H, 24A-24C, and 26A-26B, as well as with previous FIGS. 1-22.

FIGS. 26A-26B are like FIG. 7A-7B with the addition of Faraday Cages, as well as the addition of stacked dies in a side view in FIG. 26B. Advantageous combinations of the FIGS. 26A-26B embodiments can be made with embodiments shown in FIGS. 23A-23H, 24A-24C, and 25A-25B, as well as with previous FIGS. 1-22.

By way of background, FIG. 28A of the '033 and '930 Applications incorporated by reference herein above shows in cross-section an example of a tire 535, such as for a wheel 533 of a transportation vehicle, with a device 510; the internal sipe 505 and/or inner compartment/chamber/bladder 501 can be pressured or not (valve not shown). As shown in the example, inner compartment/chamber/bladder 501 can have one or more direct attachments 503 to the wheel and the structural elements shown can be made of any useful material as is conventional in the art, including plastic and/or plastic composite and/or carbon fiber. The outer compartment/chamber/bladder 500 can be abbreviated to cover only part of inner compartment/chamber/bladder 501, as shown in FIG. 28A, (possibly pressure-sealed to the wheel like a conventional automobile tire and wheel); the outer compartment/chamber/bladder 500 can also be abbreviated further to cover only a lesser portion, including at least a tread portion, which can include rubber (natural or synthetic, as can other or all parts of the outer compartment 500. FIG. 28B of the '033 and '930 applications shows in a side view cross-section an example of shape of structural elements 502 of the inner compartment 501 (not shown for simplicity).

FIG. 27A is new in this application and shows another tire 535 example embodiment similar to that of FIG. 28A discussed in the previous paragraph, but maximizing lateral stability by locating the structural elements 502 at the sides of the tire 535, while maximizing soft ride by locating the media such as gas in the central portion of the tire 535. New FIG. 27B is a side view of FIG. 27A and is the same as FIG. 28B discussed above.

FIGS. 23A-27 can be combined in any manner with each other and with any or all of FIGS. 1-22 of this applications, as well as with the Figures of the applicant's patents and applications incorporated by reference herein this application.

Broadly, the flexible inserts or components 510, 511, and 513 can be usefully employed anywhere that cushioning already is being used, or could be with beneficial effect, such as protective padding or cases for equipment of any sort, including portable devices like PC laptops or video players and/or games, cell phones, personal digital assistants (PDA's), and personal digital music players like Apple Ipods™ and MP3 players, as examples, such as the mounting of delicate electronic (or other) components like hard-drives or for vibration dampening, such as in automobile structural and body components and connections.

The applicant's two earlier applications, U.S. application Ser. No. 11/190,087 published as Publication No. US 2005/0268487 A1 on Dec. 8, 2005 describing footwear and U.S. application Ser. No. 11/108,034 published as Publication No. US 2005/0217142 A1 on Oct. 6, 2005 describing orthotics, as well as U.S. Pat. No. 7,010,869, issued Mar. 14, 2006 (of which the '034 application is a continuation), are hereby expressly incorporated by reference in its entirety for com-

pleteness of disclosure. The applicant's earlier application Ser. No. 11/179,887 published as Publication No. US 2005/0241183 A1 on Nov. 3, 2005 describing footwear is hereby expressly incorporated by reference in its entirety for completeness of disclosure.

The applicant's other footwear U.S. Pat. Nos. 4,989,349; 5,317,819; 5,544,429; 5,909,948; 6,115,941; 6,115,945; 6,163,982; 6,308,439; 6,314,662; 6,295,744; 6,360,453; 6,487,795; 6,584,706; 6,591,519; 6,609,312; 6,629,376; 6,662,470; 6,675,498; 6,675,499; 6,708,424; 6,729,046; 6,748,674; 6,763,616; 6,789,331; 6,810,606; 6,877,254; 6,918,197; 7,010,869; 7,082,697; 7,093,379; 7,127,834; 7,168,185; 7,174,658; 7,234,249; 7,287,341; 7,334,350; and 7,334,356 are all hereby incorporated by reference herein in their entirety into this application for completeness of disclosure of the applicant's novel and useful combination of one or more of any of the features or components of any of the figures of this application with one or more of any of the features of any one or more of the preceding applicant's patents listed above in this paragraph.

The applicant's other footwear U.S. Applications with Publication Numbers US 20020000051; 20020007571; 20020007572; 20020014020; 20020014021; 20020023373; 20020073578; 20020116841; 20030046830; 20030070320; 20030079375; 20030131497; 20030208926; 20030217482; 20040134096; 20040250447; 20050016020; 20050086837; 20050217143; 20060032086; 20060248749; 20070240332; 20070271817; 20080000108; 20080005931; 20080022556; 20080083140; and 20080086916 are hereby incorporated by reference herein in their entirety into this application for completeness of disclosure of the applicant's novel and useful combination of one or more of any of the features or components of any of the figures of this application with one or more of any of the features of any one or more of the preceding applicant's published U.S. Applications listed above in this paragraph.

The applicant's non-footwear patents on global network computers, U.S. Pat. Nos. 6,167,428; 6,732,141; 6,725,250; 7,024,449; 7,035,906, and 7,047,275 are all hereby incorporated by reference herein in their entirety into this application for completeness of disclosure of the applicant's novel and useful combination of one or more of any of the features or components of any of the figures of this application with one or more of any of the features of any one or more of the preceding applicant's patents listed above in this paragraph.

The applicant's non-footwear applications on global network computers are U.S. application Ser. Nos. 09/085,755; 09/884,041; 09/935,779; 10/663,911; 11/196,527; 11/329,423; and 11/338,887, as well as U.S. application Ser. No. 10/802,049 with U.S. Publication Number US 2004/0215931 published Oct. 28, 2004; U.S. application Ser. No. 10/684,657 with U.S. Publication Number US 2005/0180095 published Aug. 18, 2005; U.S. application Ser. No. 11/196,527 filed Aug. 4, 2005 with U.S. Publication Number US 2006/0095497 published May 4, 2006; U.S. application Ser. No. 11/329,423 filed Jan. 11, 2006 with U.S. Publication Number US 2006/0177226 published Aug. 10, 2006; U.S. application Ser. No. 11/338,887 filed Jan. 25, 2006 with U.S. Publication Number US 2006/0190565 published Aug. 24, 2006; all of these applications are hereby incorporated by reference herein in their entirety into this application for completeness of disclosure of the applicant's novel and useful combination of one or more of any of the features or components of any of the figures of this application with one or more of any of the features of any one or more of the preceding applicant's applications, including published applications, listed above in this paragraph.

To avoid confusion, any numeral in the above listed non-footwear patents or applications relating to computers that is the same as a numeral in the above listed footwear patents or applications should have (or be presumed to have) a prefix numeral of "1" added to the numeral (the equivalent of adding "1000" to the numeral, so that all the numerals of both sets of applications and patents remain unique).

In the following claims, the term "chamber" means a compartment **161** or a chamber **188** or a bladder and the term "sipe" means a sipe **505** or a slit or a channel or a groove as described in the textual specification above and associated figures of this application.

The foregoing shoe designs meet the objectives of this invention as stated above. However, it will clearly be understood by those skilled in the art that the foregoing description has been made in terms of the preferred embodiments and various changes and modifications may be made without departing from the scope of the present invention which is to be defined by the appended claims.

What is claimed is:

1. A computer, comprising:

an undiced semiconductor wafer comprising a multitude of microchips,

each of the multitude of microchips including one or more core microprocessors configured to allow the microchip to function independently and including independent communication capabilities;

an outer chamber including a Faraday Cage;

at least one inner chamber inside said outer chamber;

said outer chamber and said inner chamber being separated at least in part by an internal sipe; and

wherein said internal sipe is formed by at least part of an inner surface of said outer chamber and at least part of an outer surface of said inner chamber which oppose each other and are separate from each other and therefore can move relative to each other; and

at least a portion of said opposing surface parts are in contact with each other in a unloaded condition; and each of the multitude of microchips includes at least one internal hardware firewall.

2. The computer according to claim 1, wherein each of the multitude of microchips includes at least one hardware master controlling device that is protected by at least one said internal hardware firewall.

3. The computer according to claim 1, wherein the independent communication capabilities include at least a wireless one of a radio or optical device.

4. The computer according to claim 1, wherein the independently functioning microchips each include a microprocessor, a random access memory, a radio, and digital signal processor circuitry.

5. The computer according to claim 1, wherein incomplete microchips located around the periphery of the wafer, and microchips having a manufacturing defect or other damage, are deactivated or disconnected.

6. The computer according to claim 1, wherein the wafer has interconnects between the microchips.

7. The computer according to claim 1, wherein two or more wafers are stacked together.

8. The computer according to claim 1, wherein three or more wafers are stacked together.

9. The computer according to claim 1, wherein the undiced semiconductor wafer includes a curved outer portion.

10. The computer according to claim 1, wherein at least a portion of said surfaces forming said sipe are separated by a cooling media when unloaded.

11. The computer according to claim 1, further including a photovoltaic cell or fuel cell or battery or a combination of two or all three.

12. The computer according to claim 1, wherein the inner chamber includes the undiced semiconductor wafer.

13. A computer according to claim 1, wherein each of the multitude of microchips comprises:

a microprocessor, the microprocessor including at least two cores;

one or more network communication components; and at least a primary internal hardware firewall;

said primary internal hardware firewall is configured to protect a hardware protected side of the microchip's hardware and separate the hardware protected side of the microchip's hardware from an unprotected network side of the microchip's hardware that is not protected by said primary internal hardware firewall; at least one of the cores of the microprocessor is located within said hardware protected side;

one or more of the cores of the microprocessor and said one or more network communications components are located within said unprotected hardware network side of the microchip, and said unprotected network side of the microchip being configured for connection to a network and being located between said primary internal hardware firewall and a wired or wireless network connection to said network; and

said one or more unprotected networked cores being separate hardware components from said one or more network communications components, and both said unprotected cores and said network communications components being separate from said primary internal hardware firewall.

14. The computer according to claim 13, wherein at least one secondary interior hardware firewall is configured to form at least one separate hardware protected compartment; and

at least one core is located in said at least one separate hardware protected compartment.

15. A computer, comprising:

a plurality of undiced semiconductor wafers stacked together, each wafer comprising a multitude of microchips,

the multitude of microchips each including one or more core microprocessors configured to allow the microchip to function independently and including independent communication capabilities;

an outer chamber including a Faraday Cage;

at least one inner chamber inside said outer chamber;

said outer chamber and said inner chamber being separated at least in part by an internal sipe; and

wherein said internal sipe is formed by at least part of an inner surface of said outer chamber and at least part of an outer surface of said inner chamber which oppose each other and are separate from each other and therefore can move relative to each other; and

at least a portion of said opposing surface parts are in contact with each other in an unloaded condition; and each of the multitude of microchips includes an internal hardware firewall.

16. The computer according to claim 15, wherein each of the multitude of microchips includes at least one hardware master controlling device that is protected by at least one said internal hardware firewall.

17. The computer according to claim 15, wherein at least one of the independently functioning microchips includes at least one functional component on two or more separate wafers.

18. The computer according to claim 17, wherein the functional components are located proximate to one another on the separate wafers.

19. The computer according to claim 17, where the functional components are located on three semiconductor wafers.

20. The computer according to claim 15, wherein incomplete microchips located around the periphery of the plurality of wafers, and microchips having a manufacturing defect or other damage, are deactivated or disconnected.

21. The computer according to claim 15, wherein the plurality of wafers has interconnects between the microchips.

22. The computer according to claim 15, wherein three or more wafers are stacked together.

23. The computer according to claim 15, wherein the independent communication capabilities include at least a wireless one of a radio or an optical device.

24. The computer according to claim 15, wherein the independently functioning computers each include a microprocessor, a random access memory, a radio, and a digital signal processor.

25. The computer according to claim 15, wherein at least one of the plurality of undiced semiconductor wafers includes a curved outer portion.

26. The computer according to claim 15, wherein at least a portion of said surfaces forming said sipe are separated by a cooling media when unloaded.

27. The computer according to claim 15, further including a photovoltaic cell or fuel cell or battery or a combination of two or all three.

28. The computer according to claim 15, wherein the inner chamber includes the plurality of undiced semiconductor wafers.

29. A computer according to claim 15, wherein each of the multitude of microchips comprises:

a microprocessor, the microprocessor including at least two cores;

one or more network communication components; and

at least a primary internal hardware firewall;

said primary internal hardware firewall is configured to protect a hardware protected side of the microchip's hardware and separate the hardware protected side of the microchip's hardware from an unprotected network side of the microchip's hardware that it not protected by said primary internal hardware firewall; at least one of the cores of the microprocessor is located within said hardware protected side;

one or more of the cores of the microprocessor and said one or more network communications components are located within said unprotected hardware network side of the microchip, and said unprotected network side of the microchip being configured for connection to a network and being located between said primary internal hardware firewall and a wired or wireless network connection to said network; and

said one or more unprotected networked cores being separate hardware components from said one or more network communications components, and both said unprotected cores and said network communications components being separate from said primary internal hardware firewall.

30. The computer according to claim 29, wherein at least one secondary interior hardware firewall is configured to form at least one separate hardware protected compartment; and

at least one core is located in said at least one separate hardware protected compartment.

31. A computer, comprising:

at least a section of an undiced semiconductor wafer comprising a multitude of microchips, the multitude of microchips each including one or more core microprocessors configured to allow the microchip to function independently and including independent communication capabilities;

an outer chamber;

at least one inner chamber inside said outer chamber; said outer chamber and said inner chamber being separated at least in part by an internal sipe; and

at least a portion of a surface of said outer chamber forming at least a portion of a surface of said internal sipe;

said internal sipe has opposing surfaces that are separate from each other and therefore can move relative to each other;

at least a portion of said opposing surfaces are in contact with each other in a unloaded condition; and

the outer chamber including a Faraday Cage; and each of the multitude of microchips includes an internal hardware firewall.

32. The computer according to claim 31, wherein each of the multitude of microchips includes at least one hardware master controlling device that is protected by at least one said internal hardware firewall.

33. The computer according to claim 31, wherein the section includes a part of a plurality of undiced semiconductor wafers stacked together, each wafer having a multitude of microchips.

34. The computer according to claim 31, wherein the independent communication capabilities include at least a wireless one of a radio or optical device.

35. The computer according to claim 31, wherein the independently functioning microchips each include a microprocessor, a random access memory, a radio, and digital signal processor circuitry.

36. The computer according to claim 31, wherein incomplete microchips located around the periphery of the wafer, and microchips having a manufacturing defect or other damage, are deactivated or disconnected.

37. The computer according to claim 31, wherein the wafer has interconnects between the microchips.

38. The computer according to claim 31, wherein the section includes at least one half or at least one quarter of the wafer.

39. The computer according to claim 31, wherein the section of the undiced semiconductor wafer is a section of one of three or more wafers stacked together.

40. The computer according to claim 31, wherein the undiced semiconductor wafer includes a curved outer portion.

41. The computer according to claim 31, wherein at least a portion of said surfaces forming said sipe are separated by a cooling media when unloaded.

42. The computer according to claim 31, further including a photovoltaic cell or fuel cell or battery or a combination of two or all three.

43. The computer according to claim 31, wherein the section is non-rectangular.

44. A computer according to claim 31, wherein each of the multitude of microchips comprises:

a microprocessor, the microprocessor including at least two cores;

one or more network communication components; and

at least a primary internal hardware firewall;

said primary internal hardware firewall is configured to protect a hardware protected side of the microchip's hardware and separate the hardware protected side of the microchip's hardware from an unprotected network side of the microchip's hardware that it not protected by said primary internal hardware firewall; at least one of the cores of the microprocessor is located within said hardware protected side;

one or more of the cores of the microprocessor and said one or more network communications components are located within said unprotected hardware network side of the microchip, and said unprotected network side of the microchip being configured for connection to a network and being located between said primary internal hardware firewall and a wired or wireless network connection to said network; and

said one or more unprotected networked cores being separate hardware components from said one or more network communications components, and both said unprotected cores and said network communications components being separate from said primary internal hardware firewall.

45. The computer according to claim 44, wherein at least one secondary interior hardware firewall is configured to form at least one separate hardware protected compartment; and

at least one core is located in said at least one separate hardware protected compartment.

\* \* \* \* \*