



US008312529B2

(12) **United States Patent**
Ellis

(10) **Patent No.:** **US 8,312,529 B2**

(45) **Date of Patent:** ***Nov. 13, 2012**

(54) **GLOBAL NETWORK COMPUTERS**

(76) Inventor: **Frampton E. Ellis**, Jasper, FL (US)

(*) Notice: Subject to any disclaimer, the term of this patent is extended or adjusted under 35 U.S.C. 154(b) by 0 days.

This patent is subject to a terminal disclaimer.

(21) Appl. No.: **13/283,274**

(22) Filed: **Oct. 27, 2011**

(65) **Prior Publication Data**

US 2012/0042372 A1 Feb. 16, 2012

Related U.S. Application Data

(60) Continuation of application No. 12/164,661, filed on Jun. 30, 2008, which is a division of application No. 10/684,657, filed on Oct. 15, 2003, now abandoned, which is a continuation-in-part of application No. 09/935,779, filed on Aug. 24, 2001, now Pat. No. 7,506,020, and a continuation-in-part of application No. PCT/US02/29227, filed on Sep. 16, 2002, said application No. 09/935,779 is a continuation-in-part of application No. 09/571,558, filed on May 16, 2000, now Pat. No. 7,035,906, and a continuation-in-part of application No. 09/213,875, filed on Dec. 17, 1998, now Pat. No. 6,725,250, and a continuation-in-part of application No. 09/085,755, filed on May 27, 1998, now Pat. No. 7,635,529, said application No. 09/571,558 is a continuation-in-part of application No. 09/315,026, filed on May 20, 1999, now Pat. No. 7,024,449, and a continuation-in-part of application No. 09/085,755, filed on May 27, 1998, now Pat. No. 7,634,529, and a continuation-in-part of application No. 09/213,875, filed on Dec. 17, 1998, now Pat. No. 6,725,250, said application No. 09/315,026 is a division of application No. 09/213,875, filed on Dec. 17, 1998, now Pat. No. 6,725,250, which is a continuation-in-part of application No. PCT/US97/21812, filed on Nov. 28, 1997, and a continuation-in-part of application No.

PCT/US98/27058, filed on Dec. 17, 1998, said application No. 09/213,875 is a continuation-in-part of application No. 08/980,058, filed on Nov. 26, 1997, now Pat. No. 6,732,141, said application No. 09/085,755 is a continuation-in-part of application No. 08/980,058, filed on Nov. 26, 1997, now Pat. No. 6,732,141, and a continuation-in-part of application No. PCT/US97/21812, filed on Nov. 28, 1997.

(60) Provisional application No. 60/323,701, filed on Sep. 21, 2001, provisional application No. 60/322,474, filed on Sep. 17, 2001, provisional application No. 60/227,660, filed on Aug. 25, 2000, provisional application No. 60/308,826, filed on Aug. 1, 2001, provisional application No. 60/086,516, filed on May 22, 1998, provisional application No. 60/135,851, filed on May 24, 1999, provisional application No. 60/135,852, filed on May 24, 1999, provisional application No. 60/136,759, filed on May 28, 1999, provisional application No. 60/086,588, filed on May 22, 1998, provisional application No. 60/086,516, filed on May 22, 1998, provisional application No. 60/086,948, filed on May 27, 1998, provisional application No. 60/087,587, filed on Jun. 1, 1998, provisional application No. 60/088,459, filed on Jun. 8, 1998, provisional application No. 60/134,552, filed on May 17, 1999, provisional application No. 60/068,366, filed on Dec. 19, 1997, provisional application No. 60/066,313, filed on Nov. 21, 1997, provisional application No. 60/066,415, filed on Nov. 24, 1997, provisional application No. 60/031,855, filed on Nov. 29, 1996, provisional application No. 60/032,207, filed on Dec. 2, 1996, provisional application No. 60/033,871, filed on Dec. 20, 1996, provisional application No. 60/418,177, filed on Oct. 15, 2002.

(51) **Int. Cl.**
G06F 9/00 (2006.01)
G06F 1/24 (2006.01)
H04L 29/06 (2006.01)

(52) **U.S. Cl.** **726/11; 726/12; 726/13; 726/14; 713/100; 713/151; 713/153; 713/154**

(58) **Field of Classification Search** **726/11, 726/12, 13, 14; 713/100, 151, 153, 154**

See application file for complete search history.

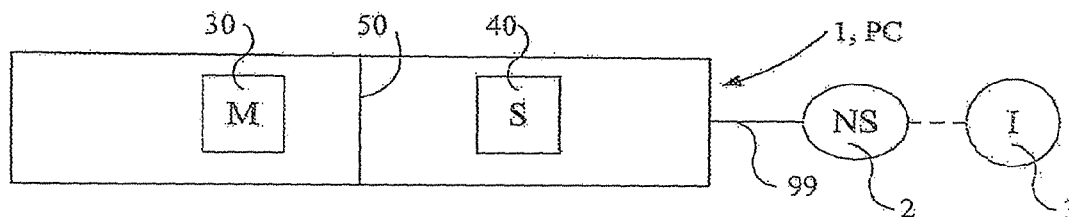

(56)

References Cited

U.S. PATENT DOCUMENTS

4,245,306 A	1/1981	Besemer et al.	5,761,507 A	6/1998	Govett
4,276,594 A	6/1981	Morley	5,764,889 A	6/1998	Ault et al.
4,278,837 A	7/1981	Best	5,774,337 A	6/1998	Lee et al.
4,736,317 A *	4/1988	Hu et al. 711/214	5,774,668 A	6/1998	Choquier et al.
4,747,139 A	5/1988	Taaffe	5,774,721 A	6/1998	Robinson
4,827,508 A	5/1989	Shear	5,784,551 A	7/1998	De Leva et al.
4,855,903 A *	8/1989	Carleton et al. 709/248	5,784,628 A	7/1998	Reneris
4,907,228 A *	3/1990	Bruckert et al. 714/11	5,790,431 A	8/1998	Ahrens, Jr. et al.
4,918,596 A	4/1990	Nakano	5,793,968 A	8/1998	Gregerson et al.
4,969,092 A	11/1990	Shorter	5,794,059 A	8/1998	Barker et al.
5,025,369 A	6/1991	Schwartz	5,809,190 A	9/1998	Chen
5,031,089 A	7/1991	Liu et al.	5,815,665 A	9/1998	Teper et al.
5,068,780 A	11/1991	Bruckert et al.	5,815,793 A	9/1998	Ferguson
5,103,393 A	4/1992	Harris et al.	5,826,014 A	10/1998	Coley et al.
5,109,329 A	4/1992	Strelieoff	5,828,833 A	10/1998	Belville et al.
5,109,512 A	4/1992	Bahr et al.	5,835,726 A	11/1998	Shwed et al.
5,136,708 A	8/1992	LaPourtre et al.	5,838,436 A	11/1998	Hotaling et al.
5,155,808 A	10/1992	Shimizu	5,838,542 A	11/1998	Nelson et al.
5,212,780 A	5/1993	Padgaonkar et al.	5,844,594 A	12/1998	Ferguson
5,237,507 A	8/1993	Chasek	5,845,074 A	12/1998	Kobata
5,260,943 A	11/1993	Comroe et al.	5,850,449 A	12/1998	McManis
5,282,272 A	1/1994	Guy et al.	5,861,817 A	1/1999	Palmer et al.
5,283,819 A	2/1994	Glick et al.	5,862,357 A	1/1999	Hagersten et al.
5,291,494 A	3/1994	Bruckert et al.	5,864,738 A	1/1999	Kessler et al.
5,291,502 A	3/1994	Pezeshki et al.	5,870,721 A	2/1999	Norris
5,291,505 A	3/1994	Nielsen	5,872,987 A	2/1999	Wade et al.
5,341,477 A	8/1994	Pitkin et al.	5,881,284 A	3/1999	Kubo
5,349,682 A	9/1994	Rosenberry	5,889,989 A	3/1999	Robertazzi et al.
5,357,404 A	10/1994	Bright et al.	5,896,499 A	4/1999	McKelvey
5,357,632 A	10/1994	Pian et al.	5,905,429 A	5/1999	Hornstein et al.
5,361,362 A	11/1994	Benkeser et al.	5,909,052 A	6/1999	Ohta et al.
5,381,534 A	1/1995	Shi	5,909,681 A	6/1999	Passera et al.
5,388,211 A	2/1995	Hornbuckle	5,917,629 A	6/1999	Hortensius et al.
5,392,400 A	2/1995	Berkowitz et al.	5,919,247 A	7/1999	Van Hoff et al.
5,410,651 A	4/1995	Sekizawa et al.	5,930,511 A	7/1999	Hinsley
5,426,741 A	6/1995	Butts, Jr. et al.	5,943,421 A	8/1999	Grabon
5,428,783 A	6/1995	Lake	5,964,832 A	10/1999	Kisor
5,446,843 A *	8/1995	Fucito et al. 709/221	5,978,829 A	11/1999	Chung et al.
5,457,797 A	10/1995	Butterworth et al.	6,003,133 A	12/1999	Moughanni et al.
5,475,606 A	12/1995	Muyshondt et al.	6,052,555 A	4/2000	Ferguson
5,497,465 A	3/1996	Chin et al.	6,065,118 A	5/2000	Bull et al.
5,515,511 A	5/1996	Nguyen et al.	6,067,082 A	5/2000	Enmei
5,522,070 A	5/1996	Sumimoto	6,073,209 A	6/2000	Bergsten
5,535,408 A	7/1996	Hillis	6,098,091 A	8/2000	Kisor
5,546,594 A	8/1996	Wazumi	6,112,225 A	8/2000	Kraft et al.
5,550,984 A	8/1996	Gelb	6,112,243 A	8/2000	Downs et al.
5,568,375 A	10/1996	Rausch	6,115,698 A	9/2000	Tuck et al.
5,570,270 A	10/1996	Naedel et al.	6,167,428 A	12/2000	Ellis
5,572,643 A	11/1996	Judson	6,208,634 B1	3/2001	Boulos et al.
5,586,121 A	12/1996	Moura et al.	6,219,627 B1	4/2001	Bonneau et al.
5,587,928 A	12/1996	Jones et al.	6,268,788 B1	7/2001	Gray
5,588,003 A	12/1996	Ohba et al.	6,287,949 B1	9/2001	Mori et al.
5,590,284 A	12/1996	Crosetto	6,366,472 B2	4/2002	Alina et al.
5,592,376 A	1/1997	Hodroff	6,440,775 B2	8/2002	Khoury
5,594,491 A	1/1997	Hodge et al.	6,725,250 B1	4/2004	Ellis, III
5,600,597 A	2/1997	Kean et al.	6,732,141 B2	5/2004	Ellis
5,604,882 A *	2/1997	Hoover et al. 711/121	6,772,347 B1	8/2004	Xie et al.
5,606,615 A	2/1997	Lapointe et al.	6,950,947 B1	9/2005	Purtell et al.
5,608,448 A	3/1997	Smoral et al.	7,024,449 B1	4/2006	Ellis, III
5,615,127 A	3/1997	Beatty et al.	7,035,906 B1	4/2006	Ellis, III
5,627,879 A	5/1997	Russell et al.	7,412,588 B2	8/2008	Georgiou et al.
5,666,484 A	9/1997	Orimo et al.	2001/0011294 A1	8/2001	Ellis, III
5,678,028 A	10/1997	Bershteyn et al.	2001/0013049 A1	8/2001	Ellis, III
5,680,461 A	10/1997	McManis	2001/0046119 A1	11/2001	Hamano et al.
5,680,548 A	10/1997	Trugman	2002/0059392 A1	5/2002	Ellis, III
5,696,902 A	12/1997	Leclercq et al.	2002/0087886 A1	7/2002	Ellis
5,699,528 A	12/1997	Hogan	2004/0073603 A1	4/2004	Ellis, III
5,701,507 A	12/1997	Bonneau, Jr. et al.	2004/0215931 A1	10/2004	Ellis
5,710,884 A	1/1998	Dedrick	2005/0180095 A1	8/2005	Ellis
5,734,913 A	3/1998	Iwamura et al.	2006/0095497 A1	5/2006	Ellis, III
5,748,489 A	5/1998	Beatty et al.	2006/0177226 A1	8/2006	Ellis, III
5,752,067 A *	5/1998	Wilkinson et al. 712/16	2006/0190565 A1	8/2006	Ellis, III
5,754,766 A	5/1998	Shaw et al.	2009/0031412 A1	1/2009	Ellis
5,758,077 A	5/1998	Danahy et al.	2009/0282092 A1	11/2009	Ellis
5,758,345 A	5/1998	Wang	2010/0011083 A1	1/2010	Ellis, III

FOREIGN PATENT DOCUMENTS

DE	40 08 335	9/1991
EP	0 647 052	4/1995
EP	0 840216	5/1998
EP	0 853 279	7/1998
WO	WO 94/01964	1/1994
WO	WO 95/01060	1/1995
WO	WO 98/26366	6/1998
WO	WO 99/04561	1/1999
WO	WO 99/32972	7/1999

OTHER PUBLICATIONS

File History of U.S. Appl. No. 13/240,842.
 File History of U.S. Appl. No. 11/329,423.
 File History of U.S. Appl. No. 12/364,745.
 File History of U.S. Appl. No. 12/499,555.
 File History of U.S. Appl. No. 12/822,928.
 File History of U.S. Appl. No. 12/829,120.
 File History of U.S. Appl. No. 13/016,149.
 File History of U.S. Appl. No. 13/018,089.
 File History of U.S. Appl. No. 13/180,164.
 O.M. Woodward et al., "The Omniguide Antenna, An Omnidirectional Waveguide Array for UHF-TV Broadcasts", IRE International Convention Records pp. 37-39, Mar. 1955.
 Notice of Allowance issued in U.S. Appl. No. 11/196,527, mailed Oct. 29, 2010.
 Notice of Allowance issued in U.S. Appl. No. 11/338,887, mailed Nov. 2, 2010.
 Office Action issued in U.S. Appl. No. 12/829,120, mailed Nov. 22, 2010.
 Office Action Issued in U.S. Appl. No. 12/364,745, mailed Nov. 23, 2010.
 Office Action issued in U.S. Appl. No. 12/499,555, mailed Nov. 24, 2010.
 U.S. Appl. No. 09/213,875, filed Dec. 17, 1998.
 U.S. Appl. No. 09/315,026, filed May 20, 1999.
 U.S. Appl. No. 09/320,660, filed May 27, 1999.
 U.S. Appl. No. 09/571,558, filed May 16, 2000.
 U.S. Appl. No. 09/669,730, filed Sep. 26, 2000.
 U.S. Appl. No. 12/822,928, filed Jun. 24, 2010.
 U.S. Appl. No. 12/829,120, filed Jul. 1, 2010.
 File History of U.S. Appl. No. 10/684,657.
 File History of U.S. Appl. No. 08/980,058.
 File History of U.S. Appl. No. 09/085,755.
 File History of U.S. Appl. No. 09/213,875.
 File History of U.S. Appl. No. 09/315,026.
 File History of U.S. Appl. No. 09/320,660.
 File History of U.S. Appl. No. 09/571,558.
 File History of U.S. Appl. No. 09/669,730.
 File History of U.S. Appl. No. 09/884,041.
 File History of U.S. Appl. No. 09/935,779.
 File History of U.S. Appl. No. 10/663,911.
 File History of U.S. Appl. No. 10/802,049.
 File History of U.S. Appl. No. 11/196,527.
 File History of U.S. Appl. No. 11/338,887.
 Office Action issued in U.S. Appl. No. 10/663,911, mailed Mar. 15, 2010.
 Notice of Allowance issued in U.S. Appl. No. 10/802,049, mailed Apr. 2, 2010.
 Office Action issued in U.S. Appl. No. 11/329,423, mailed Sep. 18, 2009.
 Office Action issued in U.S. Appl. No. 10/663,911, mailed Jun. 26, 2009.
 Gordon Force, Sr., "Portable Data Encryption Approaches", WESTCON/95, Conference Record: Microelectronics Communications Technology Producing Quality Production Mobile and Portable Power emerging Technologies, Nov. 7-9, 1995, pp. 413-419.
 A.D. Romig, Jr., "High Performance Microsystem Packaging: A Perspective", Microelectron Reliab., vol. 37, No. 10/11, pp. 1771-1781 (1997).
 Office Action issued in U.S. Appl. No. 10/802,049, mailed Jul. 1, 2009.

Notice of Allowance issued in U.S. Appl. No. 09/085,755, mailed Apr. 8, 2009.
 Notice of Allowance issued in U.S. Appl. No. 09/884,041, mailed Mar. 9, 2009.
 Notice of Allowance issued in U.S. Appl. No. 09/935,779, mailed Jan. 21, 2009.
 English language abstract of EP 0 647 052, published Apr. 5, 1995.
 Newton's Telecom Dictionary, "Mobile IP", p. 459, Mar. 1998.
 Holographic Quantum Computer, <http://www.unitelnw.com/holo/index> (May 1999).
 Jonathan Fahey, "Screen Grab", FORBES, pp. 52-53, Mar. 5, 2001.
 Ronald Gover et al., "TV GUY", Business Week, pp. 66-76, Mar. 12, 2001.
 "Distributed Computing", Red Herring, No. 87, pp. 166-202, Dec. 18, 2000.
 Om Malik, "Distributed Computing Redefines Computer Networks, Underpinning Innovation, Company Formation, and Investments", Red Herring, No. 86, pp. 95-96 and 105, Dec. 4, 2000.
 Alan Zeichick, "P2P Network Explained", Red Herring, No. 86, pp. 204 and 206, Dec. 4, 2000.
 "Napster is Clouding Grove's Crystal Ball"; FORTUNE, pp. 271-272, May 29, 2000.
 Final Office Action issued in U.S. Appl. No. 10/802,049 mailed Jul. 3, 2008.
 Notice of Allowance issued in U.S. Appl. No. 09/935,779 mailed Jul. 18, 2008.
 Wilkinson, Barry et al., "Parallel Programming: Techniques and Applications Using Networked Workstations and Parallel Computers", Chapter 4, Prentice-Hall, Inc., 1999.
 Baker, Lou et al., "Parallel Programming", Chapter 4, McGraw Hill Companies, Inc., 1996.
 Kayssi, A.; Harik, L.; Ferzli, R.; Fawaz, M; "FPGA-based Internet Protocol Firewall Chip"; Electronics, Circuits and Systems, 2000. ICECS 2000. The 7th IEEE International Conference on vol. 1, Dec. 17-20, 2000 pp. 318-319 vol. 1 [retrieved from IEEE database Jun. 9, 2008].
 Office Action issued in U.S. Appl. No. 10/663,911 mailed Sep. 26, 2008.
 Notice of Allowance issued in U.S. Appl. No. 09/884,041 mailed Oct. 9, 2008.
 Litzkow, et al., "Condor—A Hunter of Idle Workstations", 1988 IEEE, pp. 104-111.
 Theimer, et al., "Finding Idle Machines in a Workstation-Based Distributed System", IEEE Transactions on Software Engineering, Nov. 1989, vol. 15, No. 11, pp. 1444-1458.
 Brown et al., Special Edition Using Netscape TM 2 Second Edition, Que Corporation, 1995, Ch. 1-2.
 Gilder, "Angst and Awe on the Internet by George Gilder", Forbes ASAP, Dec. 4, 1995.
 Tandiary, et al., "Batrun: Utilizing Idle Workstations for Large-scale Computing", Summer 1996, pp. 41-48.
 Brisbin, "Shopping for Internet Access", MacUser, Dec. 1994, v. 10, p. 133(2).
 Gilder, "The Bandwidth Tidal Wave", Forbes ASAP, Dec. 5, 1994.
 N/A, "Special Report—Wonder Chips", Business Week, Jul. 4, 1994.
 N/A, "Supercomputers Divide and Conquer", The Economist; Dec. 14, 1996.
 N/A, "Cyber View World Widgets", Scientific American, May, 1997, p. 48.
 Gibbs, "Bandwidth, Unlimited", Scientific American, Jan. 1997, p. 41.
 Markoff, "A New Standard to Govern PC's with Multiple Chips, Work Stations Mimicking Supercomputers", The New Times, Oct. 28, 1997.
 N/A, "Aliens on your desktop", The Economist, Apr. 18, 1998, p. 78.
 Fox et al., "Towards Web/Java based High Performance Distributed, Computing—an Evolving Virtual Machine", as presented at 5th IEEE Int'l Symposium on High Performance Distributed Computing, Aug. 8-9, 1996, 86 pages.
 Fox, E., "Advances in interactive Digital Multimedia Systems", Computer, Oct. 1991, pp. 9-21.
 Gemmell, et al., "Multimedia Storage Servers; a Tutorial", Computer, May 1995, pp. 40-49.

- Hayes, "Computing Science: Collective Wisdom", American Scientist, Mar.-Apr. 1998, 1-8.
- Kim, B., "ATM Network: Goals and Challenges", Communications of the ACM, Feb. 1995, vol. No. 2, pp. 39-44, 109.
- Kremien, O., "Buying and Selling Computational, Power Over the Network", Proc. Of the 4th Int'l Conf. on Computer Communications and Networks, IEEE, pp. 616-619, Sep. 1995.
- Lindley, C., "JPEG-Like Image Compression, Part 2", Dr. Dobb's Journal, Aug. 1995, pp. 62-66, 102-105.
- Lindley, C., "JPEG-Like Image Compression, Part 1", Dr. Dobb's Journal, Jul. 1995, pp. 50-58, 101-102.
- Morris, J. et al., "Fault Tolerant Networks of Workstations", Proc. Of the 3rd Int'l. Conf. on High Performance Computing, IEEE, pp. 271-276, Dec. 1996.
- Nass, R., "Hardware-software combo could simplify MPEG real-time video compression", Electronic Design, May 3, 1993, p. 36.
- Nowatzky et al., "Are Crossbars Really Dead? The Case for Optical Multiprocessor Interconnect Systems", Proceedings of the Annual Symposium on Computer Architecture, ACM, vol. 22, Jun. 1995, pp. 106-115. XP 000687800.
- Ozer, "Digital Video: Shot by Shot", PC Magazine, Apr. 11, 1995, pp. 104-107, 110.
- Ozer, J., "Why MPEG is Hot", PC Magazine, Apr. 11, 1995, pp. 130-131.
- Plotkin, "The Digital Compression Facility—A Solution to Today's Compression Needs", 1994 IEEE, pp. 445-449.
- Qiao et al., "Time-Division Optical Communications in Multiprocessor Arrays", ACM, 1991, pp. 644-653, XP 000337622.
- Rincon et al., "The Changing Landscape of System-on-a-chip Design", MicroNews, Third Quarter 1999, www.chips.ibm.com/micronews/vol5_no3/rincon.html, pp. 1-10, vol. 5 No. 3.
- Sachs, M. et al., "LAN and I/O Convergence A Survey of the Issues", Computer, Dec. 1994, pp. 24-32.
- Sakano, et al., "A Three-Dimensional Mesh Multiprocessor System Using Board-to-Board Free-Space Optical Interconnects COSINE-III", IEEE, 1993, pp. 278-283, XP 000463415.
- Schroeder, E., "New Offerings Buoy MPEG as Video Standard", Desktop Computing, PC Week, May *, 1995, pp. 1-29.
- Shen et al., "A Parallel Implementation of an MPEG1 Encoder: Faster than Real-Time!", Proc. Of SPIE Conf. On Digital Video Compression, San Jose, CA, Feb. 1995.
- McHenry et al., "An FPGA-Based Coprocessor for ATM Firewalls", Field-Programmable Custom Computing Machines 1997, Apr. 16-18, 1997, pp. 30-39, XP-002157218.
- Shivan, J. et al., "Client Server Based Ray-Tracer Using ASTRA: An Asynchronous RPC Mechanism", Computer Communications, vol. 19, No. 5, pp. 445-455, May 1996.
- Marc, "New family microprocessor cores from LSI Logic extends customers system-on-a-chip, design capability" Nov. 7, 1994.
- Wall Street Journal; "Technology Brief—Advance Micro Devices Inc.: Company unveils Microchip for Hand-Held Computers"; Oct. 18, 1993.
- Geltinger, Patrick et al. "Microprocessors circa'2000," IEEE Spectrum, Oct. 1989 pp. 43-47.
- Yu, Albert. "The Future of Microprocessors," IEEE Micro, Dec. 1996, pp. 46-53.
- McWilliams. "Dell to Phase Out Computers Using Intel's Itanium," The Wall Street Journal, Online Sep. 15, 2005.
- David Pescovitz, "Power of the PC", Scientific American, pp. 27-28, (Apr. 2000).
- Stephen H. Wildstrom, "The Problem With Firewalls", Business Week, pp. 25 (Mar. 20, 2000).
- J. McH., "Build Your Own Supercomputer", FORBES, pp. 228 (Nov. 15, 1999).
- Office Action issued in co-pending U.S. Appl. No. 10/802,049 dated Sep. 17, 2007.
- Office Action issued in related U.S. Appl. No. 09/08,755 mailed Dec. 12, 2007.
- Office Action issued in related U.S. Appl. No. 09/884,041 mailed Dec. 12, 2007.
- Office Action issued in related U.S. Appl. No. 09/935,779 mailed Feb. 13, 2008.
- Notice of Allowance dated May 22, 2008 for U.S. Appl. No. 09/884,041.
- Notice of Allowance dated Jun. 25, 2008 for U.S. Appl. No. 09/085,755.
- Hare et al., "Master the Complexities of Network Security", *Internet Firewalls and Network Security*, Second Edition, pp. 325-350 and 516.
- Fox et al., Petaops and Exaops: Supercomputing on the Web, IEEE Internet Computing, vol. 1 No. 2 Mar.-Apr. 1997, pp. 38-46.
- Dincer et al., Building a World-Wide Virtual Machine Based on Web and HPCC-Technologies, "Student Technical Papers", <http://www.supercomp.org/sc96/proceedings/SC96PROC/DINCER/INDEX.HTM>, pp.1-18. (1996).
- Hobbs et al., A Remote Process Creation and Execution Facility Supporting Parallel Execution on Distributed Systems, "IEEE 1996", pp. 92-99.
- Boku et al., The Architecture of Massively Parallel Processor CP-PACS, "IEEE 1997"; pp. 31-40.
- Choi et al., A Diagnostic Network for Massively Parallel Processing Systems, "IEEE 1994", pp. 348-353.
- Beilovin et al., Network Firewalls, "IEEE Communications Magazine 1994", pp. 50-57.
- Welyi et al., "Java-to-Go—Iterative Computing Using Java", Sep. 10, 1996. <http://ptolemy.eecs.berkeley.edu/dgm/java-to-go/>.
- Sullivan et al., "A New Major SETI Project Based on Project Serendip Data and 100,000 Personal Computers" http://setiathome.ss.berkeley.edu/woody_paper.html, (1997).
- "Ein-Chip-Farewell", Elektroniknet Top News; XP-002154257 (Mar. 1999).
- "Means for Implementing Optical Interconnections for Parallel Processors", IBM Technical Disclosure Bulletin, Apr. 1991, vol. 33, No. 11, pp. 56-58, XP 000110310.
- Alexandrov et al., "SuperWeb: Research issues JaVa-Based Global Computing", Concurrency, vol. 9, No. 6, Jun. 1997, pp. 535-553.
- Baratloo et al., "Charlotte: Metacomputing on the Web", 9th International Conference on Parallel and Distributed Computing Systems (PDCS), 1996, pp. 1-8.
- Bevinakoppa et al., "Digital Image Compression on a Network of Transputers", Proc Of 5th Australian Transputer & OCCAM User Group Conference, IOS Press, Amsterdam, pp. 25-32, (Nov. 1992).
- Blumofe, R. et al., "Scheduling Large-Scale Parallel Computations on Networks of Workstations", Proc Of the 3rd IEEE Int'l Sump on High Performance Distributed Computing, pp. 96-105, Aug. 1994.
- Fields, Scott, "Hunting for Wasted Computing Power—New Software for Computing Networks Plus Idle Pc's to Work", 1993 University of Wisconsin—Madison.Internet: <http://www.cs.wise.edu/condor/doc/Wiseidea.html>.
- Brecht et al., "ParaWeb: Towards World-Wide Supercomputing", Proceedings of the Seventh-Acm SIGOPS European Workshop, Sep. 1996, 8 pgs.
- Capelio et al., "Market-Based Massively Parallel Internet Computing", Proceedings Third Working Conference on Massively Parallel Programming Models; 1998, pp. 118-129.
- Celenk, M. et al., "Parallel Task Execution in LAN's and Performance Analysis", Proc. Of the 1995 IEEE 14th Annual Int'l Phoenix Conf. on Computers and Communications, pp. 423-429, Mar. 1995.
- Chen, C.: et al., "The DBC: Processing Scientific Data Over the Internet"; Proc. Of the 16th Int'l Conf. on Distributed Computing Systems, pp. 676-679, May 1996.
- Clark, H., et al., "DAWGS-A Distributed Computer Server Utilizing Idle Workstations", Proc. Of the 5th Distributed Memory Computing Conf., IEEE, pp. 732-741, Apr. 1990.
- Fogg, C., "Survey of Software and Hardware VLC Architectures", SPIE vol. 2186, Image and Video Compression (1994), pp. 29-37.
- Szabo, B. et al., "Design Considerations for JPEG Video and Synchronized Audio in a Unix Workstation Environment", USENIX-Summer '91, pp. 353-368.
- Vetter, R., "ATM Concepts, Architectures, and Protocols", Communications of the ACM, Feb. 1995; vol. 38, No. 2, pp. 30-38, 109.
- Vetter, R. et al., "Issues and Challenges in ATM Networks", Communications of the ACM, Feb. 1995; vol. 8, No. 2, pp. 28-29.

- Waldspurger et al., "Spawn: A Distributed Computational Economy", IEEE Transactions on Software Engineering, vol. 18, No. 2; Feb. 1992, pp. 103-117 XP002124500.
- Yoshida, J., "MPEG-2 Encoders Make Show of Force, at NAR", Electronic Engineering Times, Apr. 10, 1995.
- Yu, Y. et al., "Software implementation of MPEG-II Video Encoding Using Socket Programming in LAN", SPIE vol. 2187, pp. 229-240, 1994.
- Waltz et al., "Make 'em pay: Billing Net Usage", MacWeek, vol. 6 (No. 27), p. 24 (2) (Dialog full text), (Jul. 27, 1992).
- "The Economics of Network Billing: Network Billing and Monitoring Systems can improve Efficiency and Cut Costs", IBM System User, vol. 14 (No. 11), p. 53 (1) (Dialog Fulltext), (Nov. 1993).
- "Let Your Computer Make Money While You Sleep", Newsbytes, p. 1 (Dialog Fulltext), (Aug. 16, 1996).
- Regenold et al., "A Single-Chip Multiprocessor DSP Solution for Communication Applications", ASIC Conference and Exhibit 1994, pp. 437-440.
- Geppert, L. Solid State [Trend/Development], IEEE Spectrum, v. 33, iss. 1, 1996, pp. 51-55.
- Li, Yao, "Free-space Optical Bus-based WDMA Interconnects for Parallel Computations", LEOS '92 Conference Proceedings; Lasers and Electron-Optics Society Annual Meeting, p. 588-589; Nov. 16-19, 1992.
- Dickinson et al., "An integrated Free Space Optical Bus", 1989 IEEE International Conference on Computer Design, VLSI in Computers and Processors, p. 62-65, Oct. 2-4, 1989.
- Natarajan et al., "Bi-Directional Optical Backplane Bus for General purpose Multi-Processor", Journal of Lightwave Technology, vol. 13, No. 6, p. 1031-1040, Jun. 6, 1995.
- Zhao et al., "General Purpose Bidirectional Optical Backplane: High Performance Bus for Multiprocessor Systems", Massively Parallel Processing Using Optical Interconnections, 2nd International Conference, p. 185-195, Oct. 23-24, 1995.
- Wu et al., "Microprocessor Control Signal Transmission Through Optical Fiber", Conference Record of 1992, IEEE Industry Applications Society Annual Meeting, p. 1747-1751, October 4-9, 1992.
- Fox et al., "Towards Web/Java based High Performance Distributed Computing—an Evolving Virtual Machine", www.npac.svr.edu/projects/webpace/doc/hpdc5/paper, Jun. 10, 1996, 11 pages.
- None, "PC Vision: Intel unveils, to bring PCs to Vehicles", EDGE: Work-Group Computing Report, EDGE Publishing, p. 1-2 (Oct. 28, 1996).
- The American Heritage College Dictionary 4th Ed.—definition of "firewall", (2007).
- White, "Covert Distributed Processing with Computer Viruses", Advances in Cryptology, Crypto 89, Springer LNCS, v. 435, pp. 616-619, (1990).
- Foster et al., "The Grid: Blueprint for a New Computing Infrastructure", Morgan Kaufman Publishers Inc., 1998.
- Hwang et al., "Scalable Parallel Computing", WCB McGraw-Hill, 1998.
- Wilkinson, et al., "Parallel Programming", Prentice Hall, 1998.
- Patterson et al., "Computer Architecture: A Quantitative Approach" (2nd Edition), Morgan Kaufmann Publishers, Inc., 1996.
- Culler et al., "Parallel Computer Architecture", Morgan Kaufmann Publishers Inc., 1998.
- Hennessy et al., "Computer Organization and Design", Morgan Kaufmann Publishers, Inc., 1998.
- Slater, "The Microprocessor Today", IEEE Micro 1996, pp. 32-44.
- Steinert-Threlkeld; "New Breed of Chip TI develops a super circuit", The Sun Baltimore; May 4, 1992.
- Dallas Morning News; "LSI holds plans for tiny chips Versatility of 'system on a chip' creates niche in microelectronics;" Mar. 4, 1996.
- Mokhoff, "System-on-a-chip comes to wireless arena;" Electronic Engineering Times; Feb. 12, 1996.
- Cindi; "System on a Chip stars at ISSCC;" Electronic News; Feb. 19, 1996.
- Ang; "System-on-a-chip to define next-generation set-top box"; Electronic Engineering Times; Dec. 15, 1995.

* cited by examiner

Primary Examiner — Mohammad W Reza
(74) *Attorney, Agent, or Firm* — Mendelsohn, Drucker & Assoc., P.C.; Kevin J. Dunleavy

(57)

ABSTRACT

A microchip for a computer configured to connect to a one network of computers, the microchip comprising: a first internal hardware-based firewall, the first internal hardware-based firewall configured to deny access to a portion of the microchip from the network; a general purpose microprocessor including at least two general purpose cores or general purpose processing units; a first core or processing unit is located inside of the first internal hardware-based firewall; a second core or processing unit is located outside of at the first internal hardware-based firewall; the second core or processing unit is separate from the first internal hardware-based firewall; and a memory component located inside of a second internal hardware-based firewall that is located between said memory component and a core or processing unit with which said memory component is associated. The microchip can also include a plurality of dies.

21 Claims, 35 Drawing Sheets

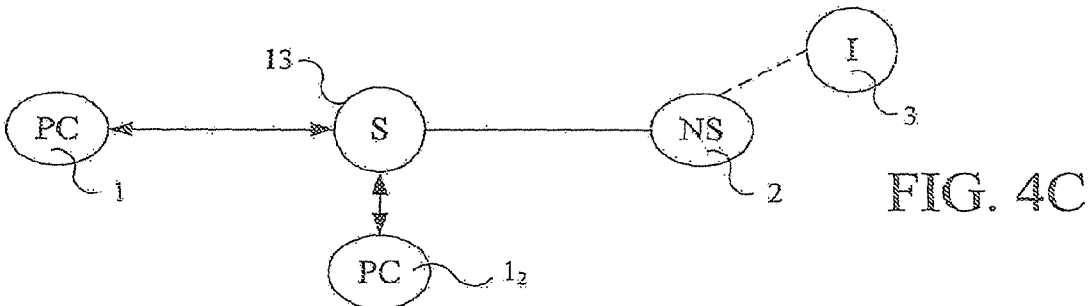
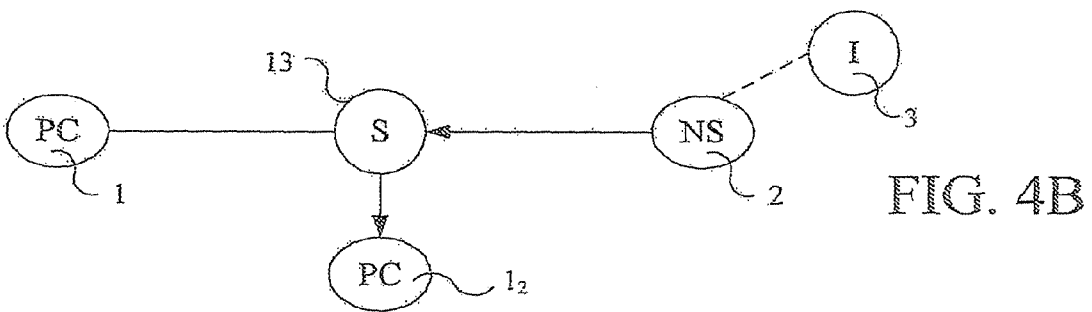
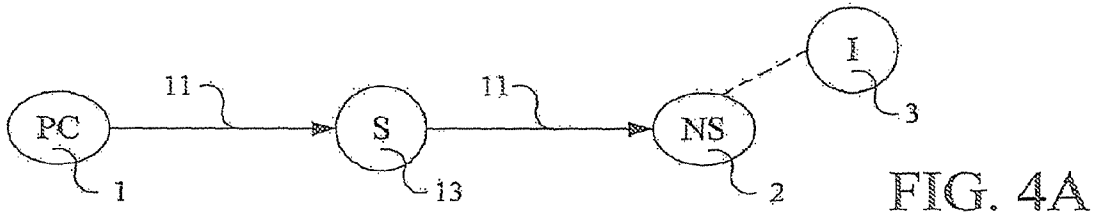
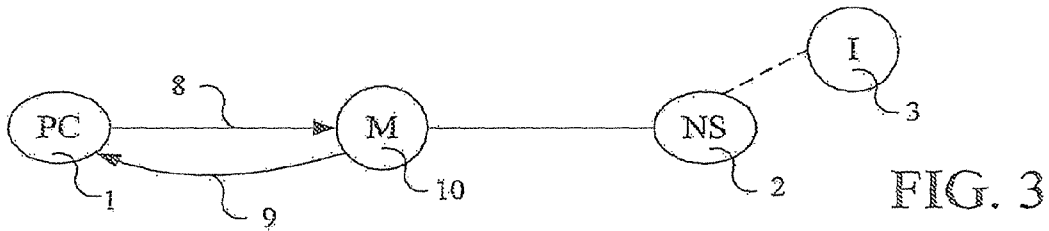
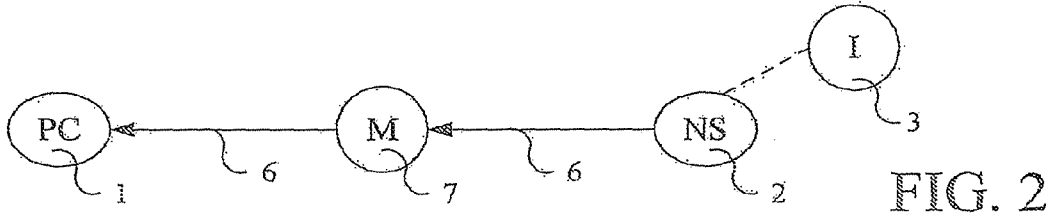
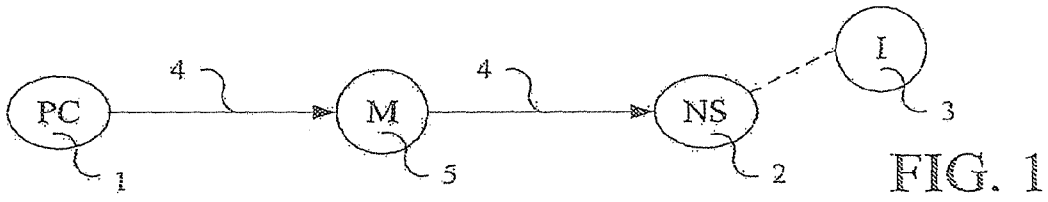

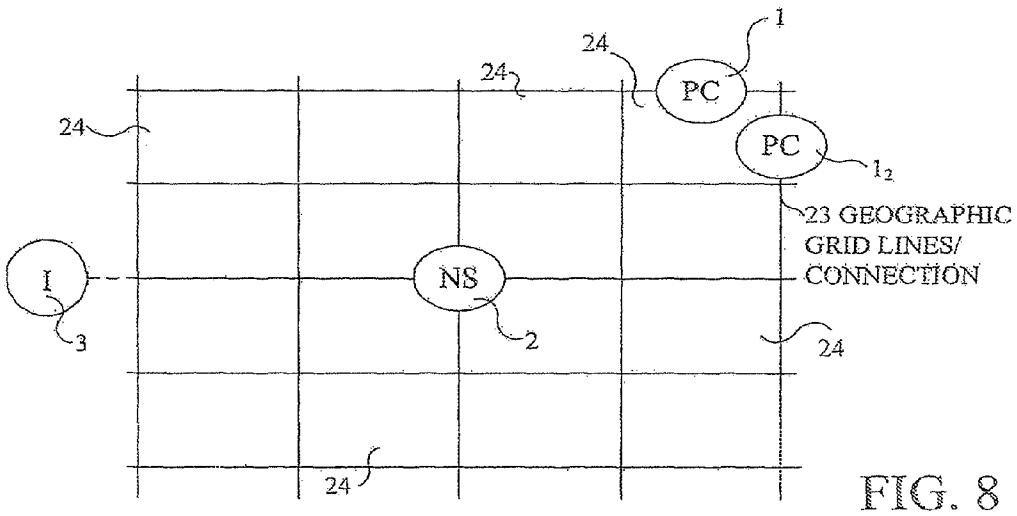
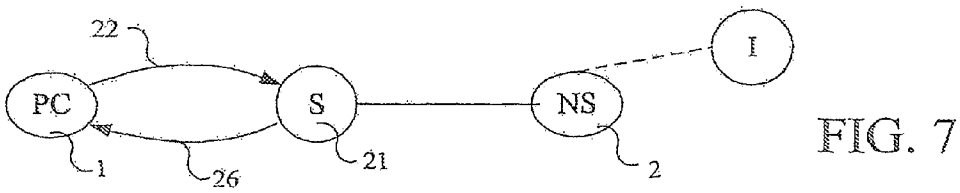
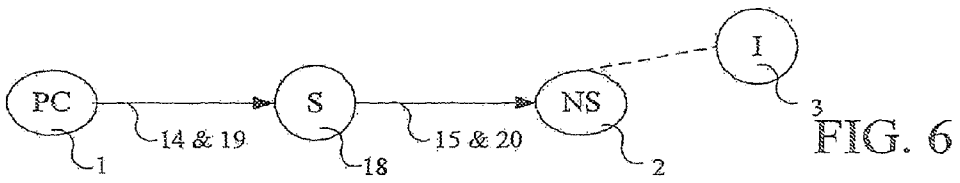
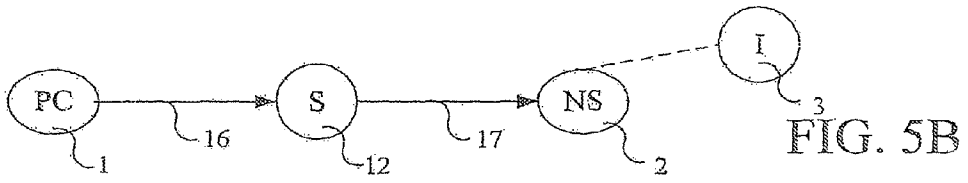
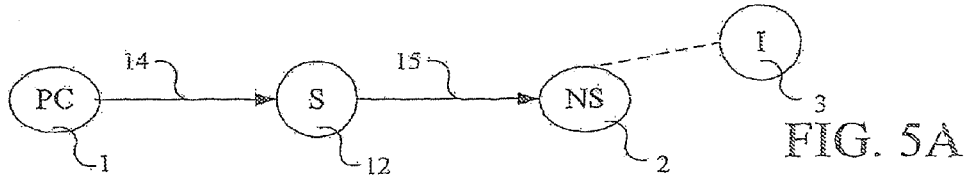

FIG. 9

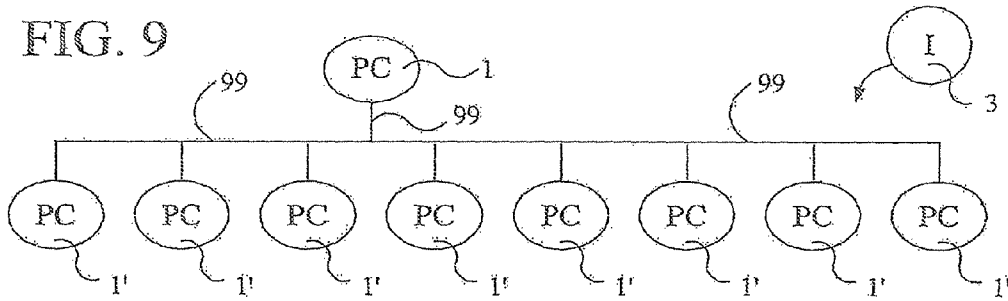

FIG. 10A

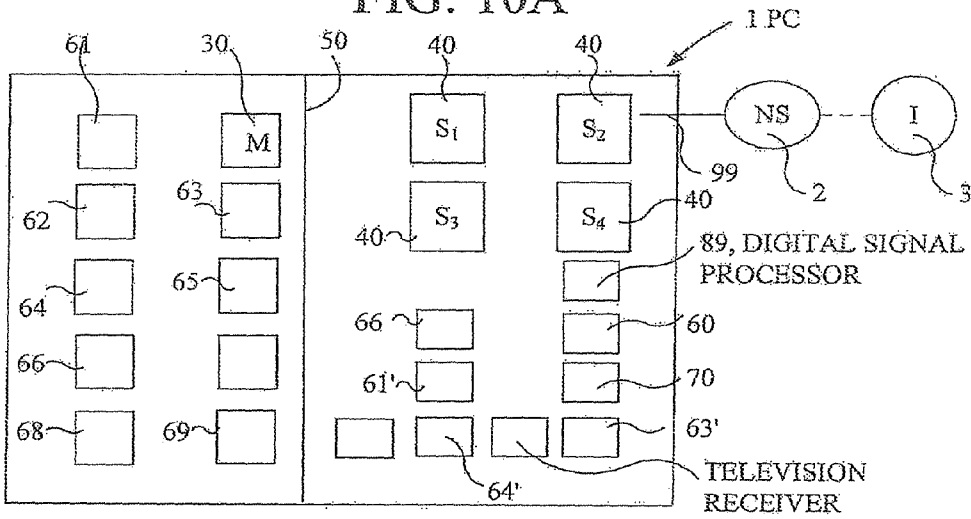

FIG. 10B

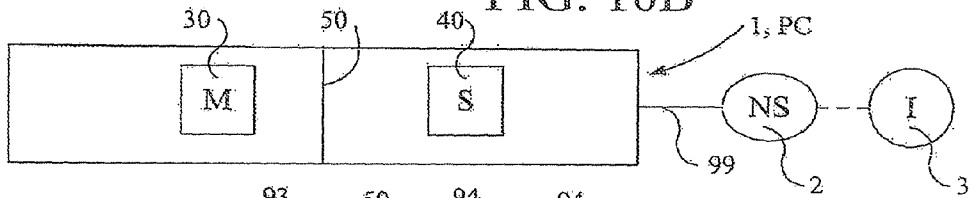
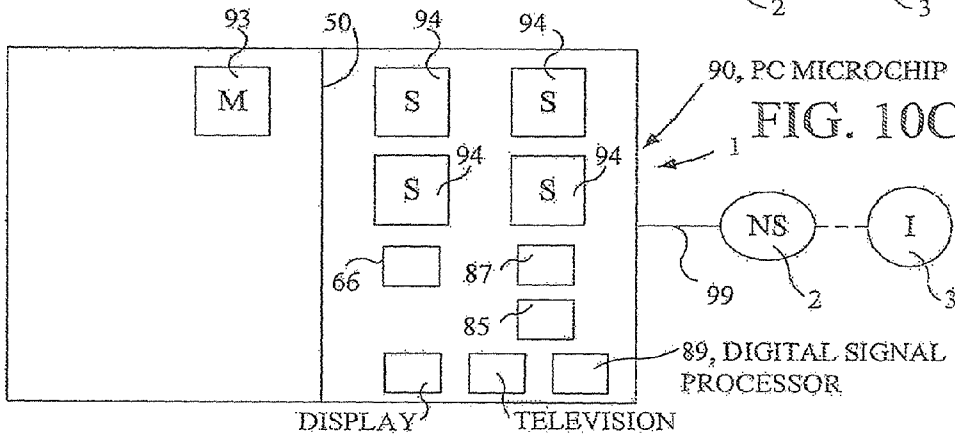

FIG. 10C



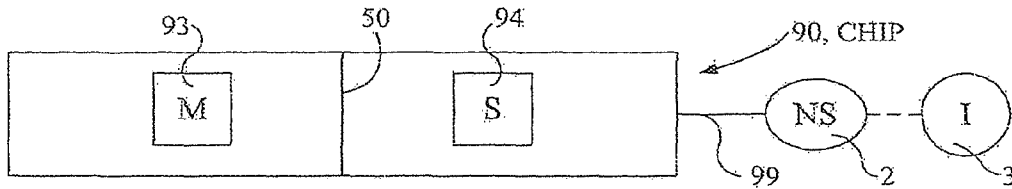

FIG. 10D

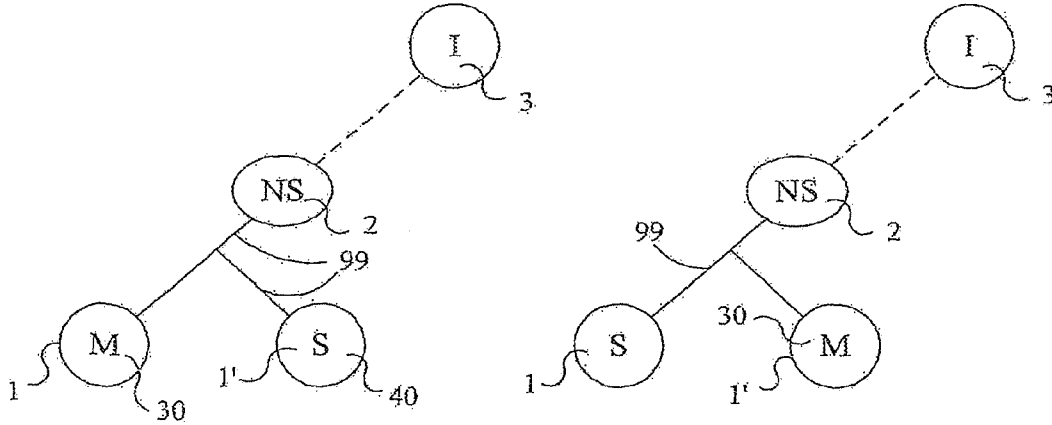

FIG. 10E

FIG. 10F

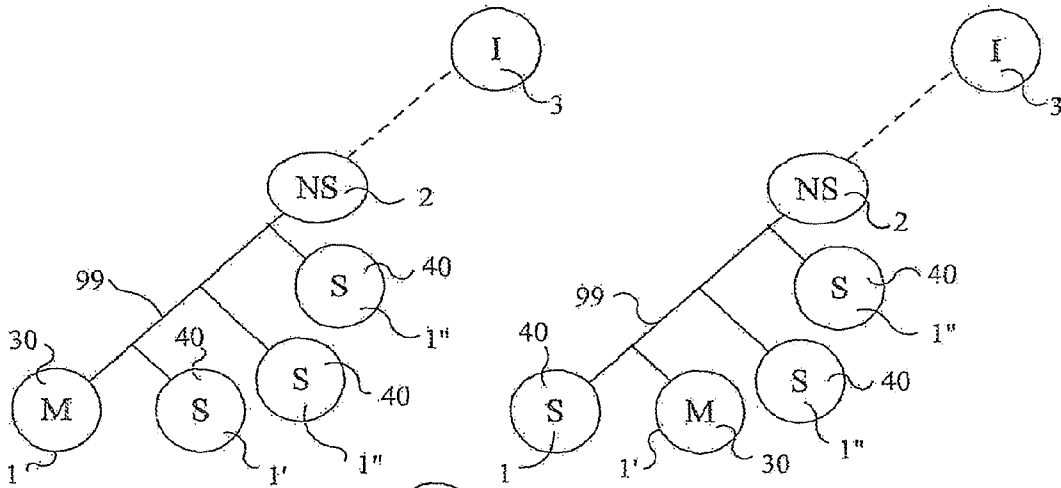

FIG. 10G

FIG. 10H

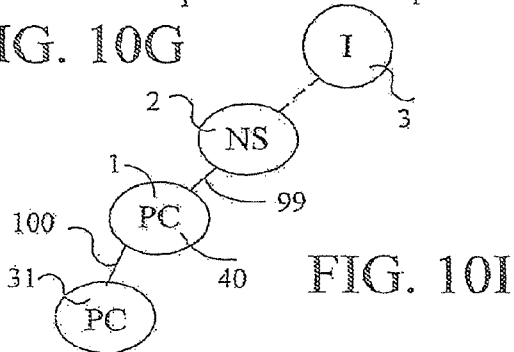

FIG. 10I

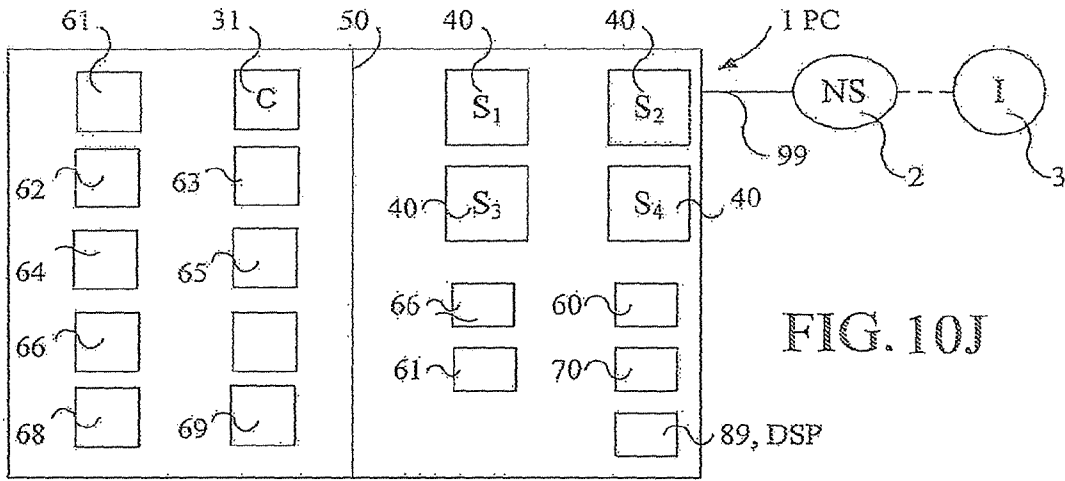

FIG. 10J

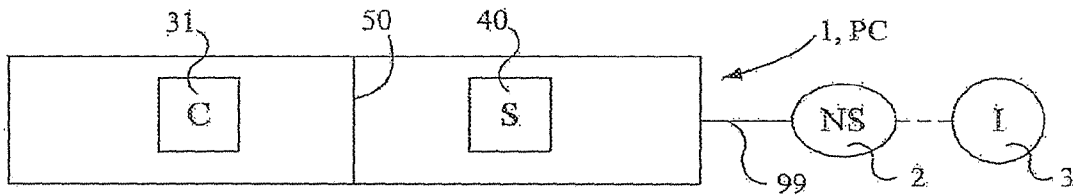

FIG. 10K

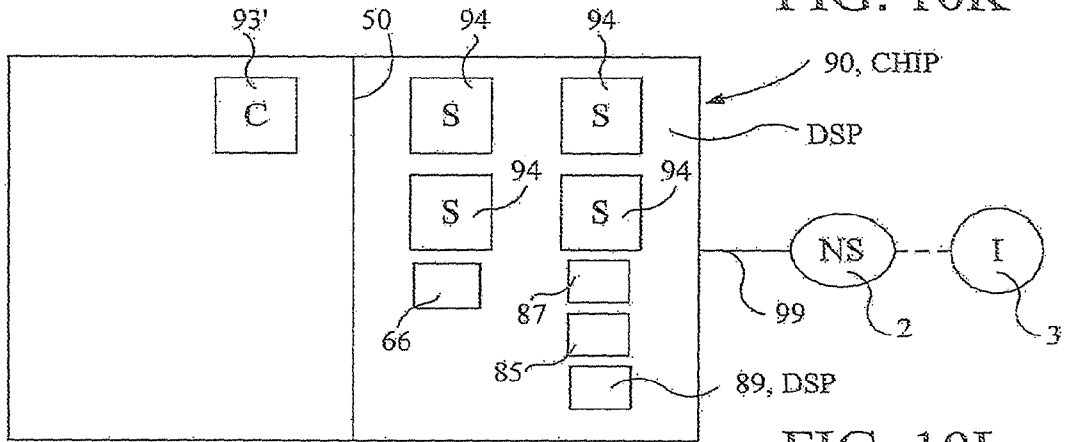

FIG. 10L

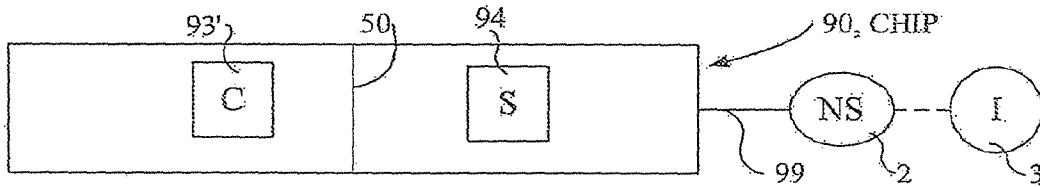

FIG. 10M

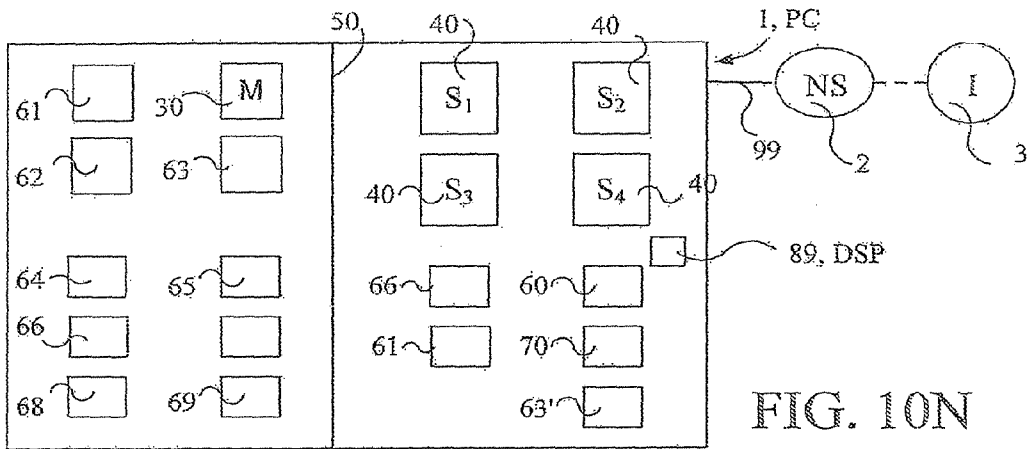

FIG. 10N

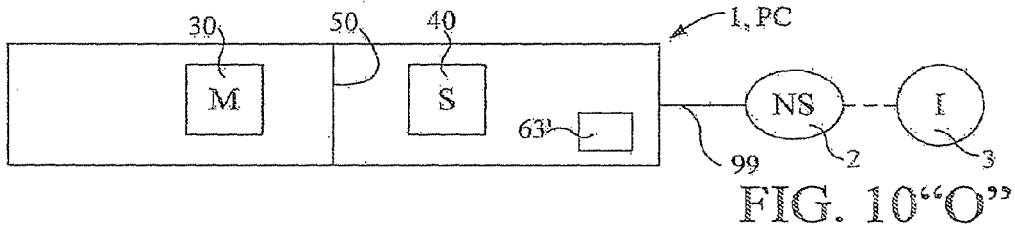

FIG. 10'O'

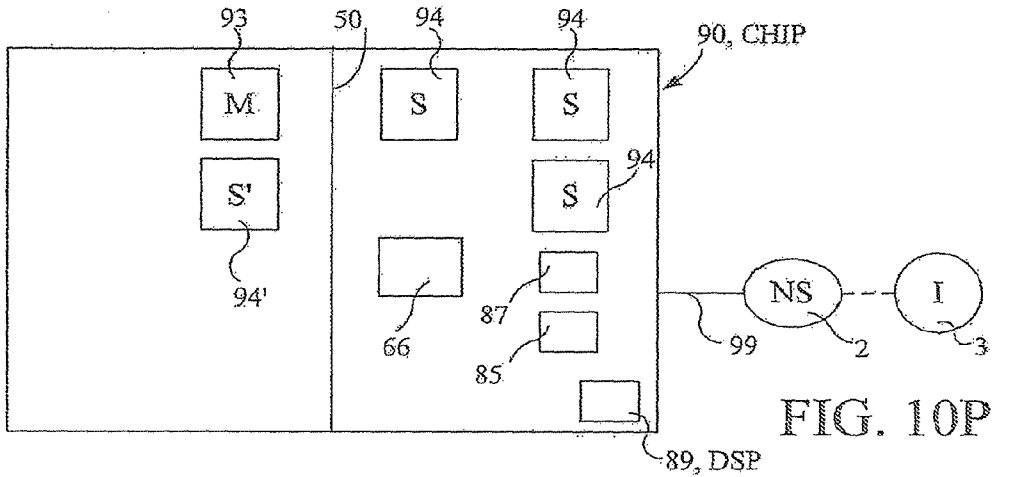

FIG. 10P

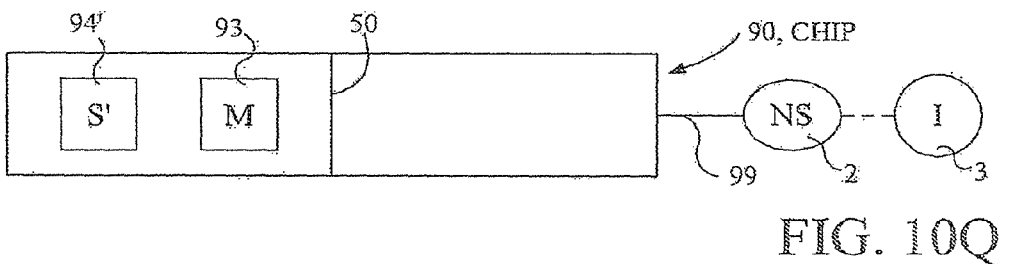

FIG. 10Q

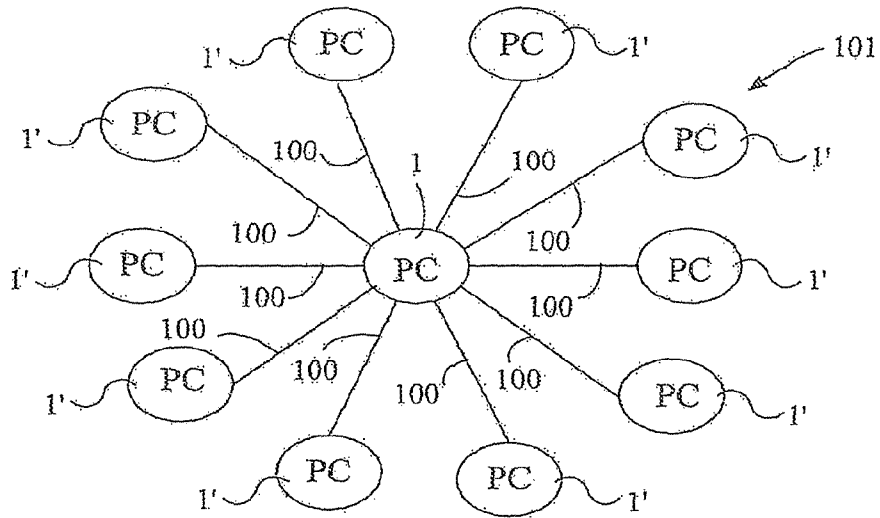

FIG. 11

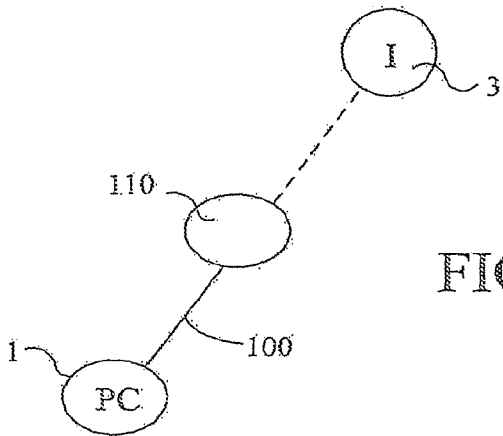

FIG. 12

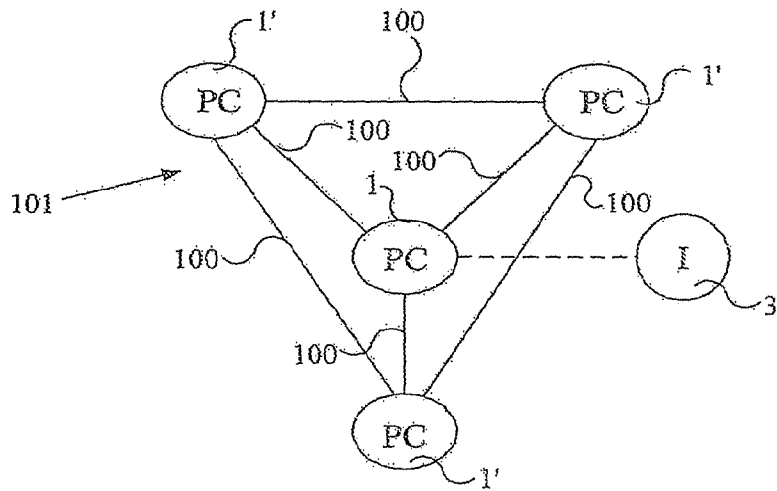

FIG. 13

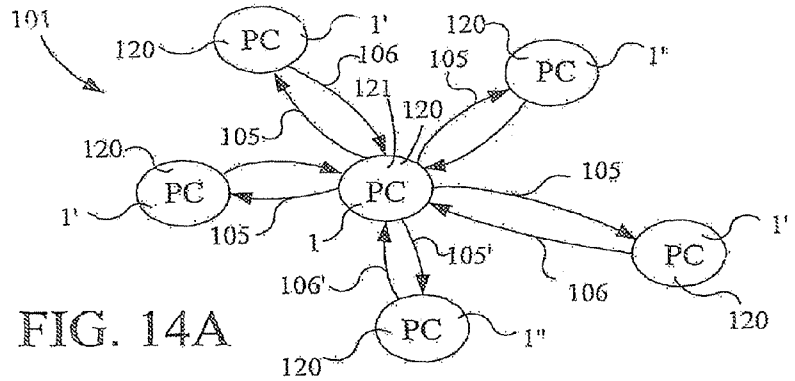

FIG. 14A

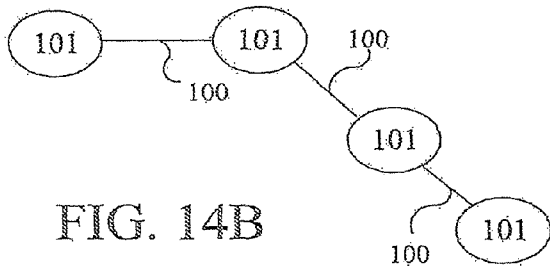

FIG. 14B

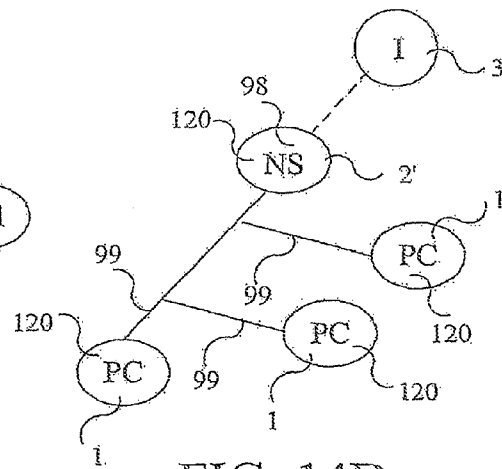

FIG. 14D

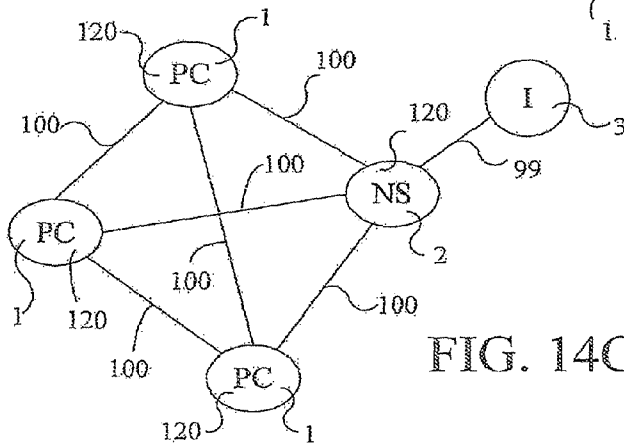

FIG. 14C

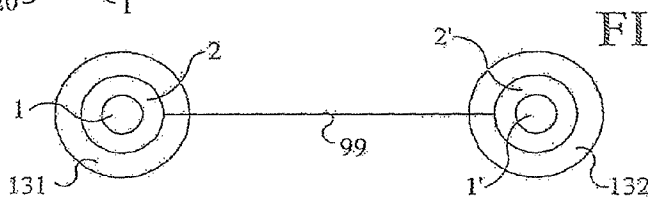

FIG. 15

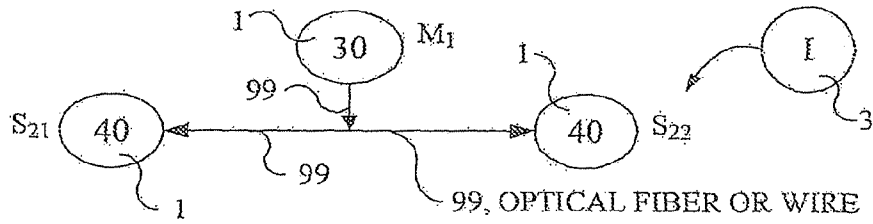

FIG. 16A

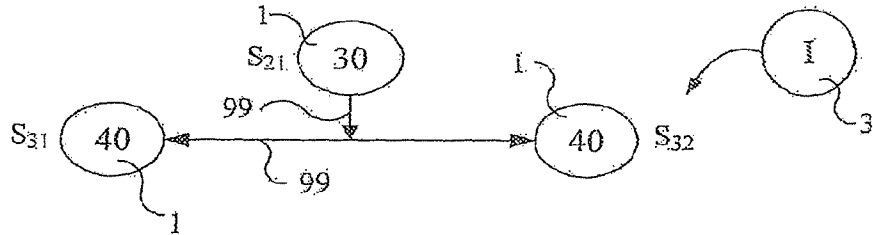

FIG. 16B

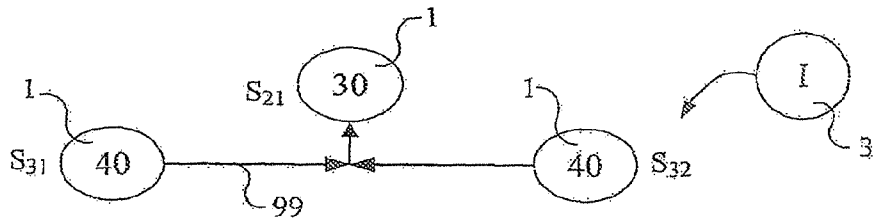

FIG. 16C

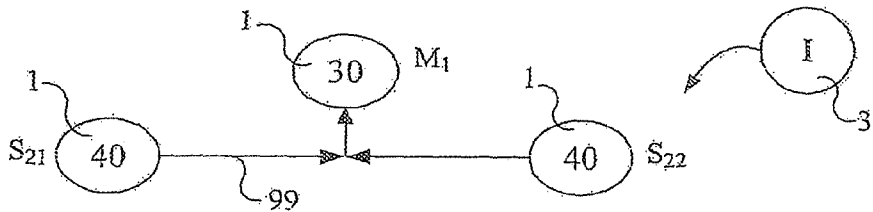

FIG. 16D

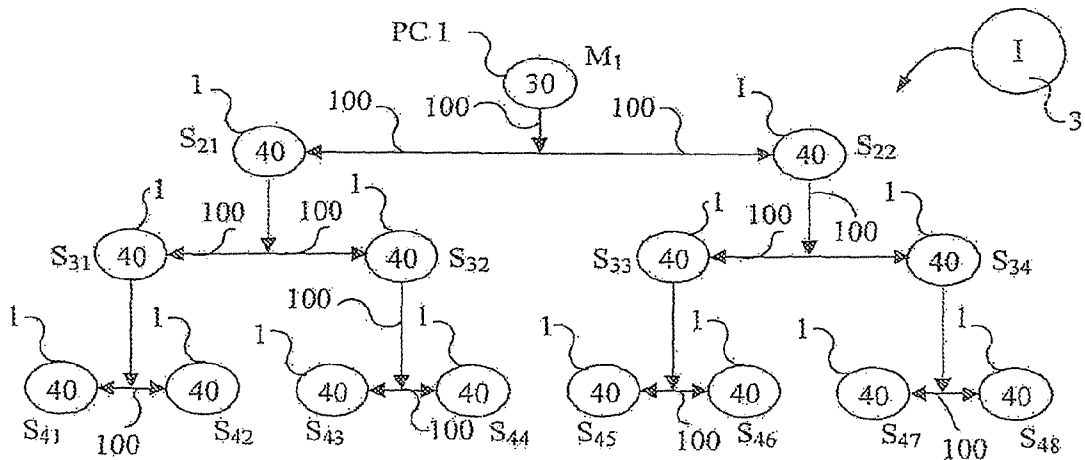

FIG. 16E

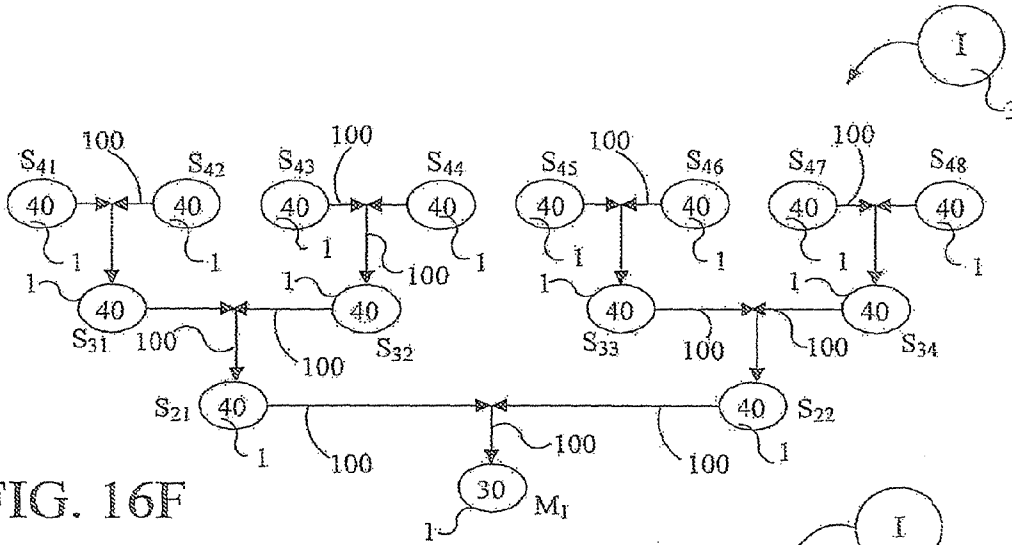

FIG. 16F

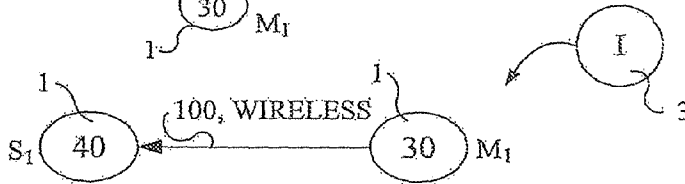

FIG. 16G

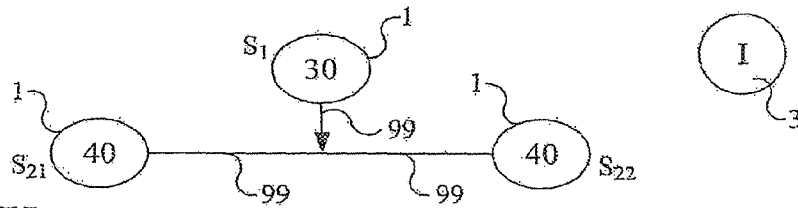

FIG. 16H

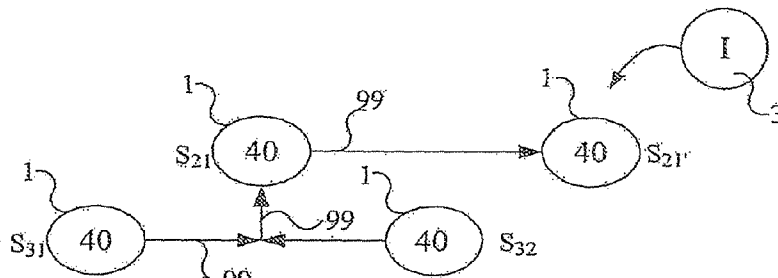

FIG. 16I

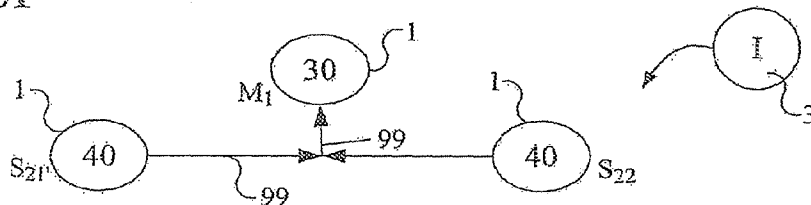
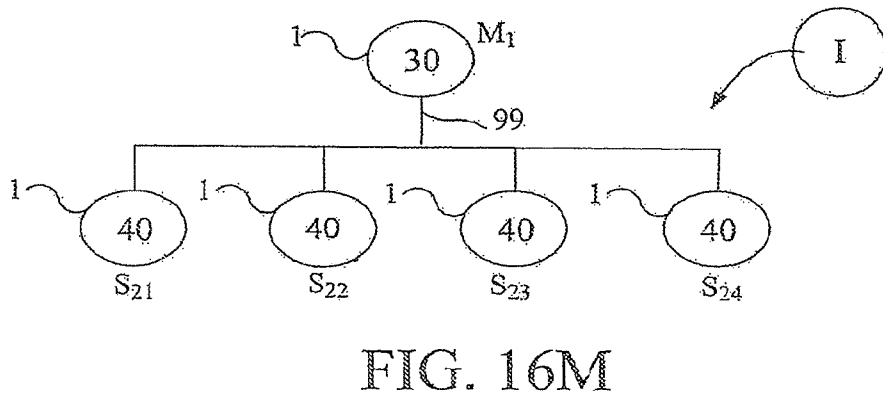
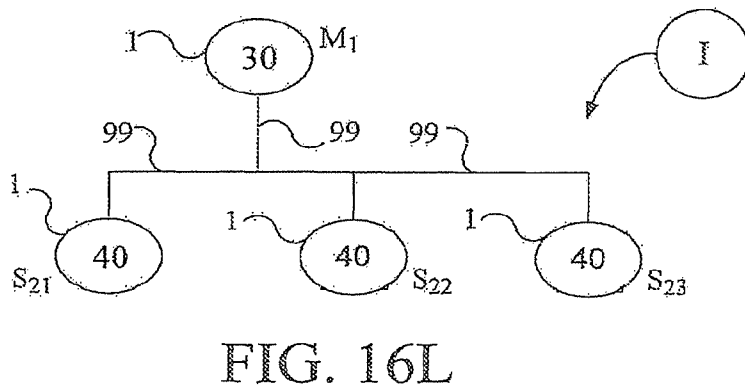
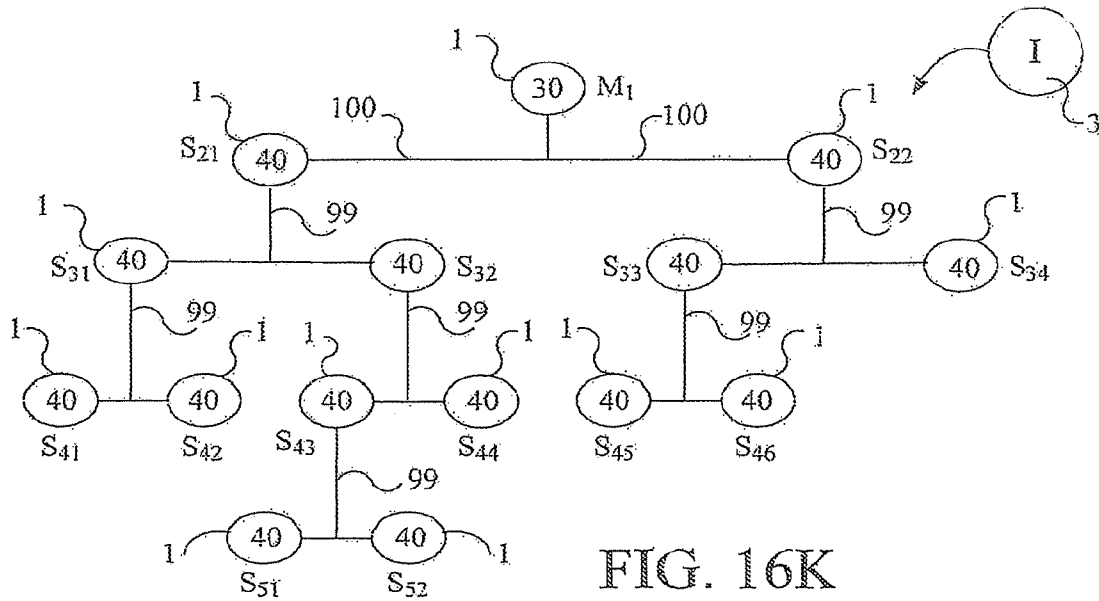

FIG. 16J



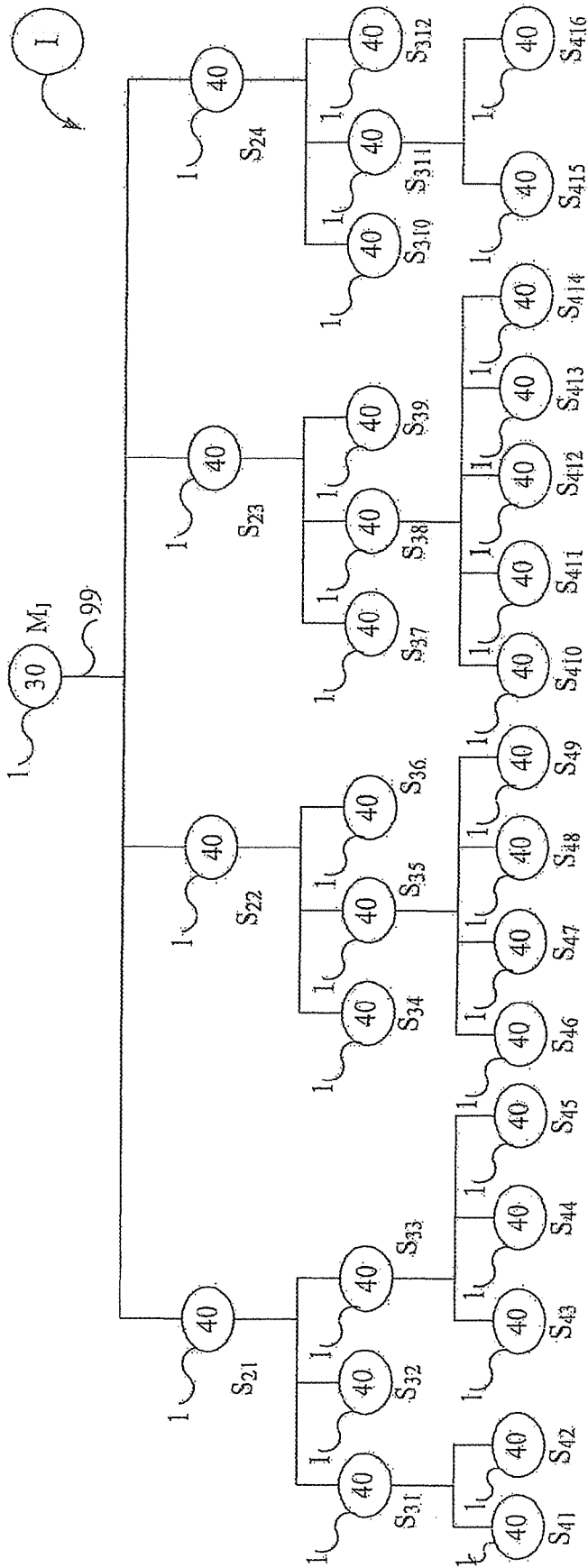

FIG. 16N

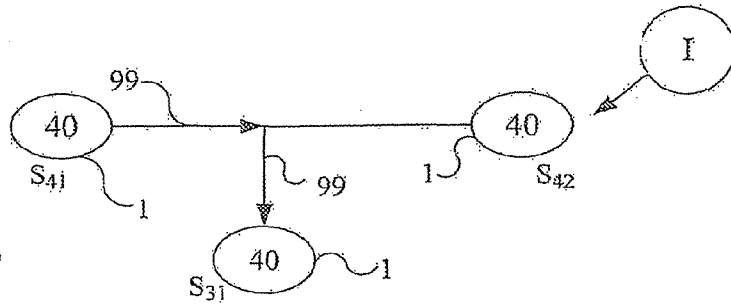

FIG. 16O

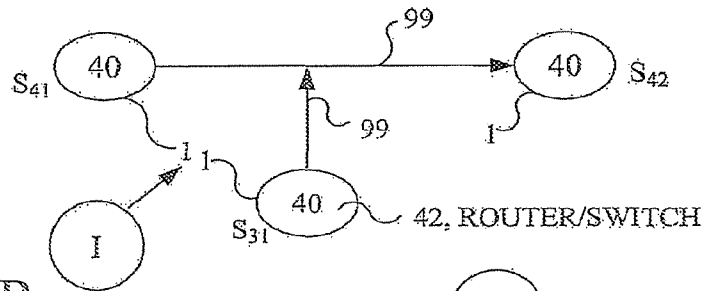

FIG. 16P

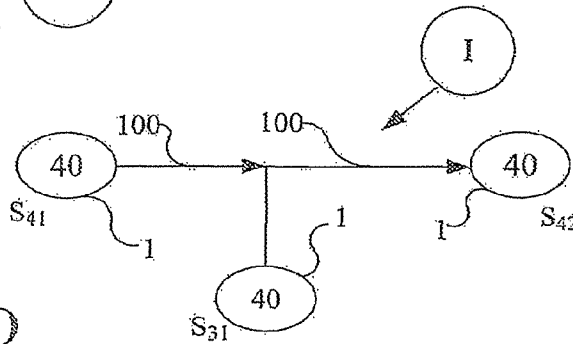

FIG. 16Q

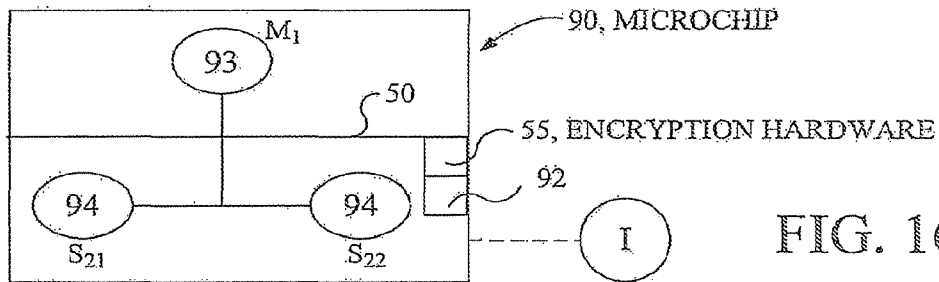

FIG. 16R

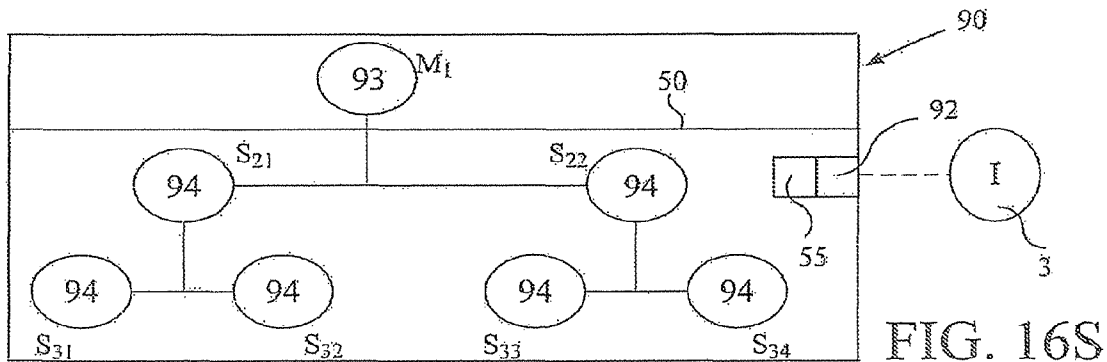

FIG. 16S

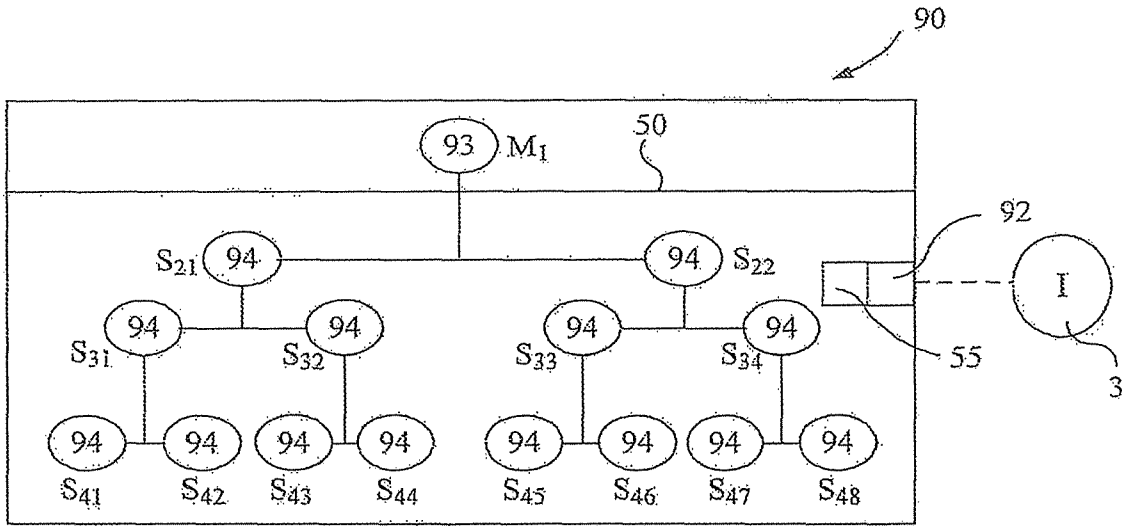

FIG. 16T

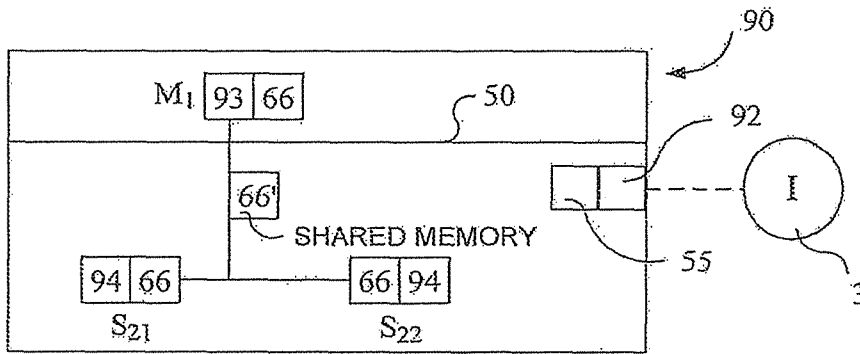

FIG. 16U

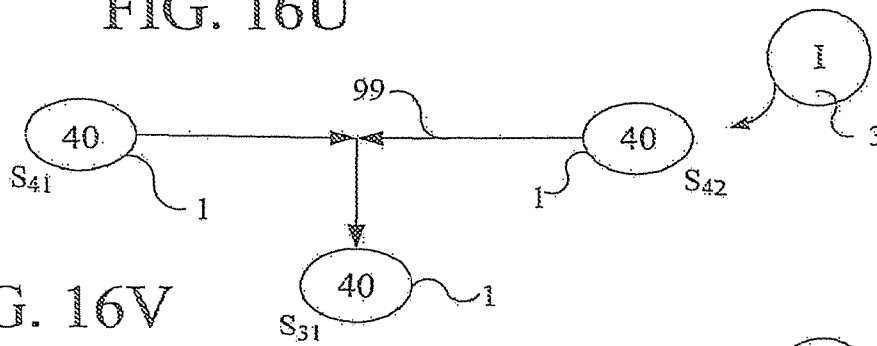

FIG. 16V

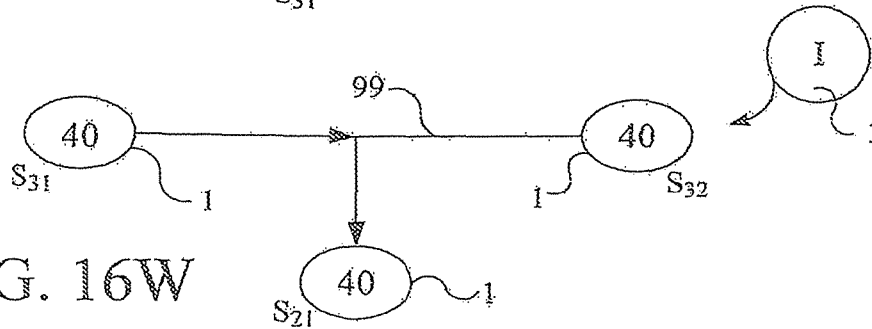

FIG. 16W

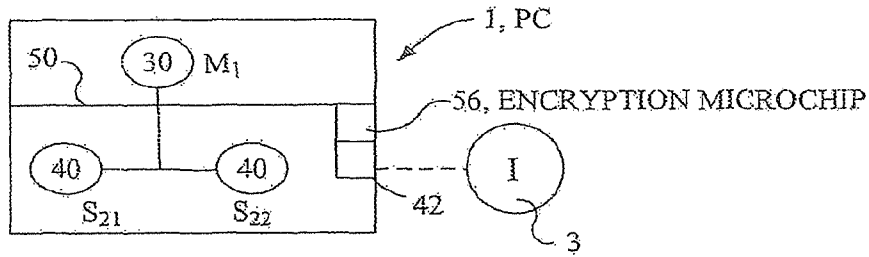

FIG. 16X

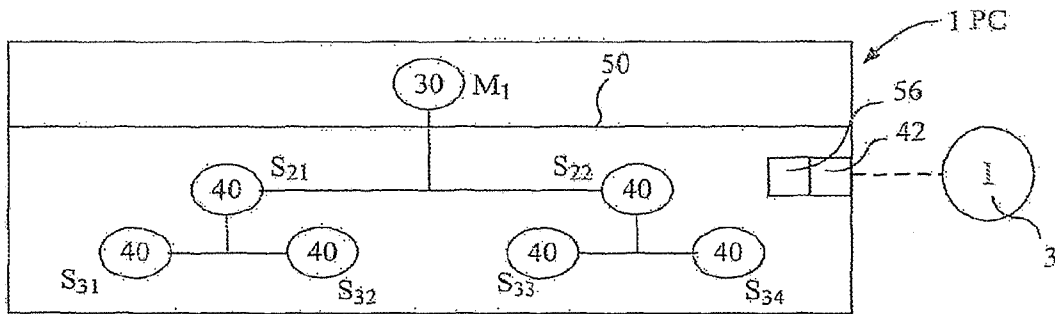

FIG. 16Y

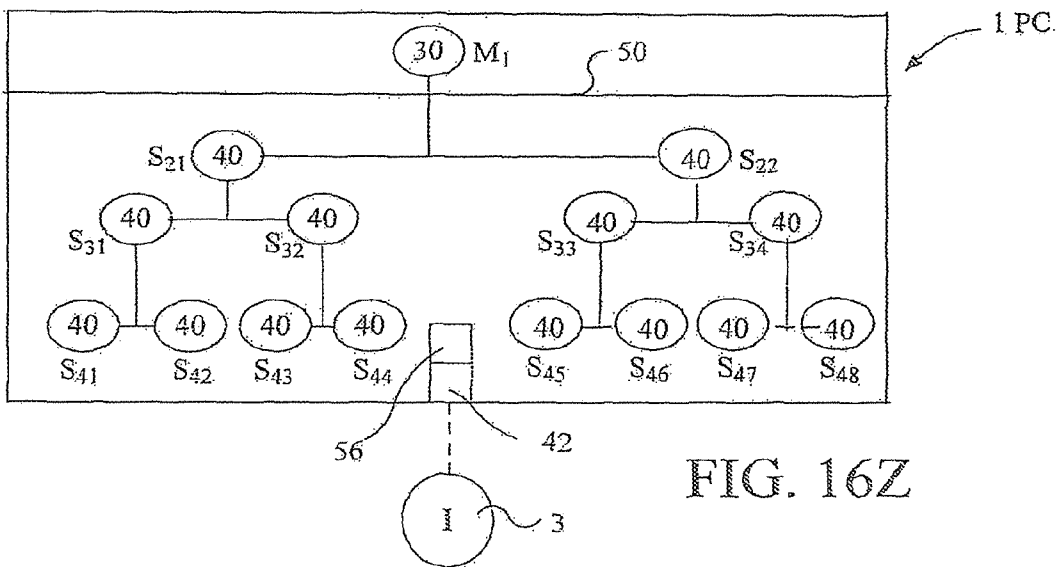

FIG. 16Z

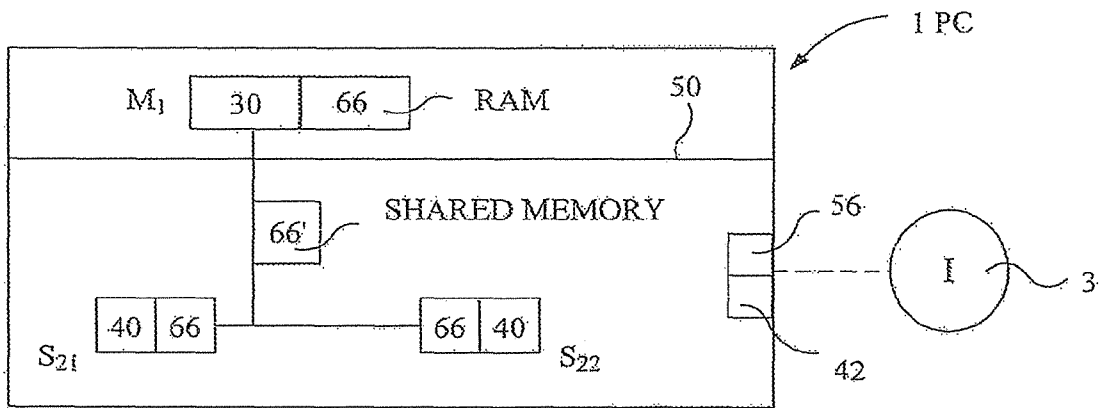

FIG. 16AA

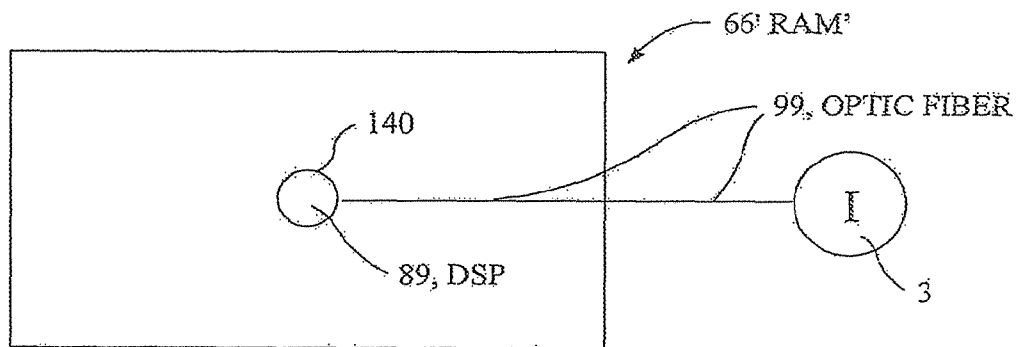

FIG. 16AB

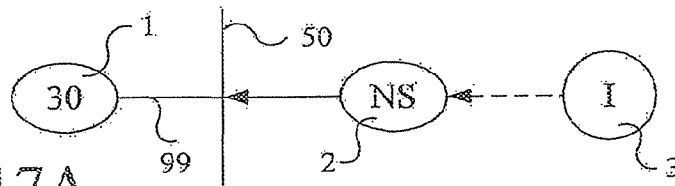

FIG. 17A

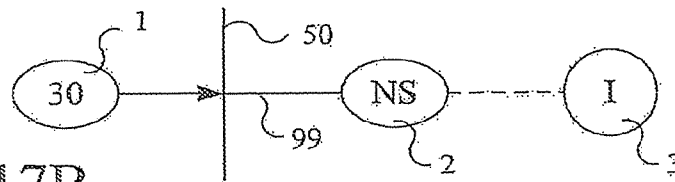

FIG. 17B

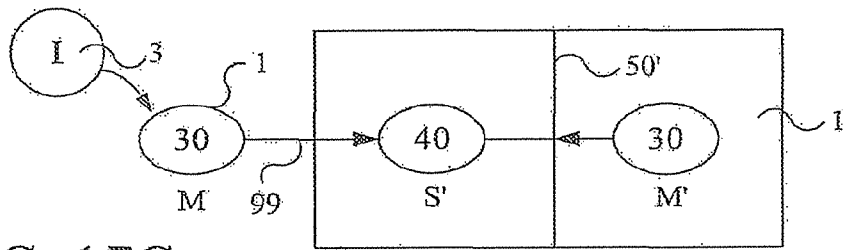

FIG. 17C

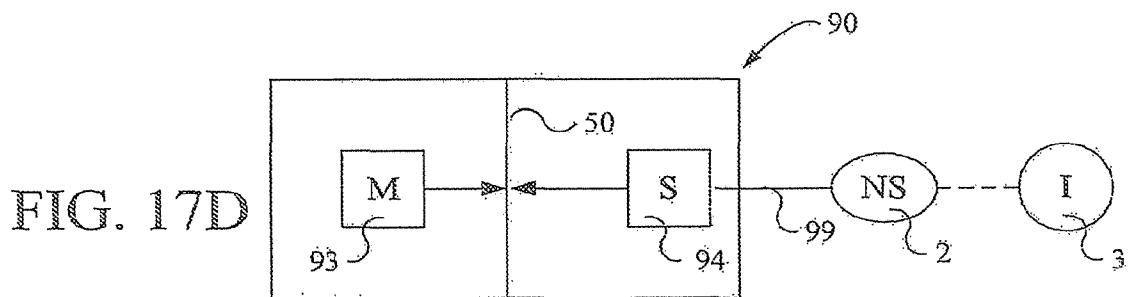

FIG. 17D

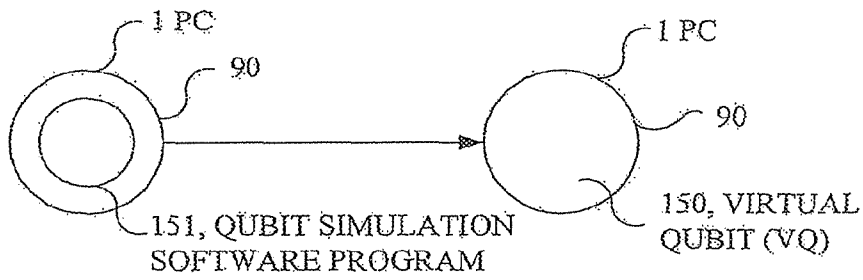

FIG. 18A

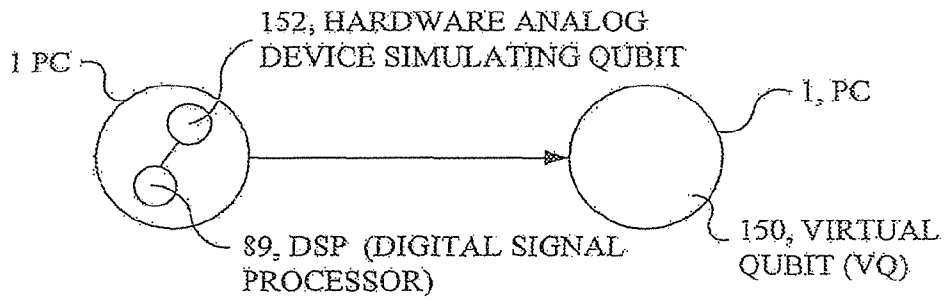
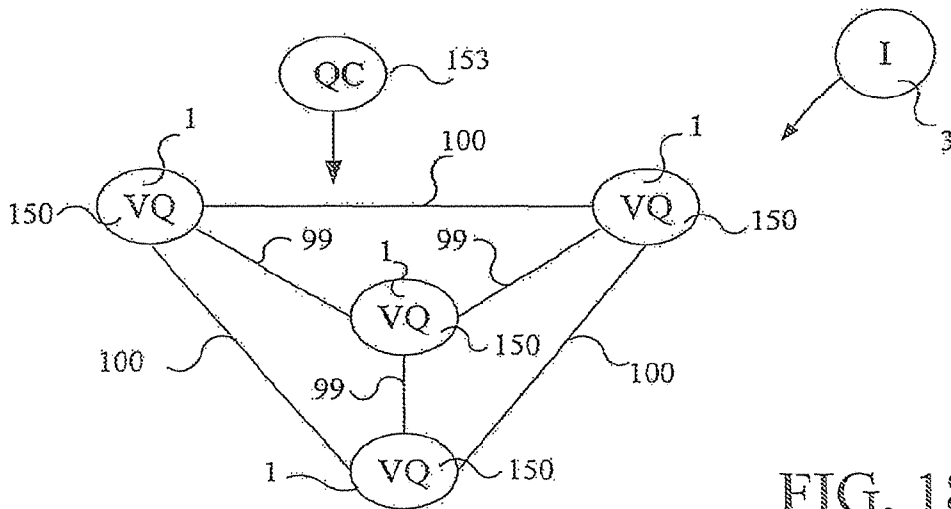
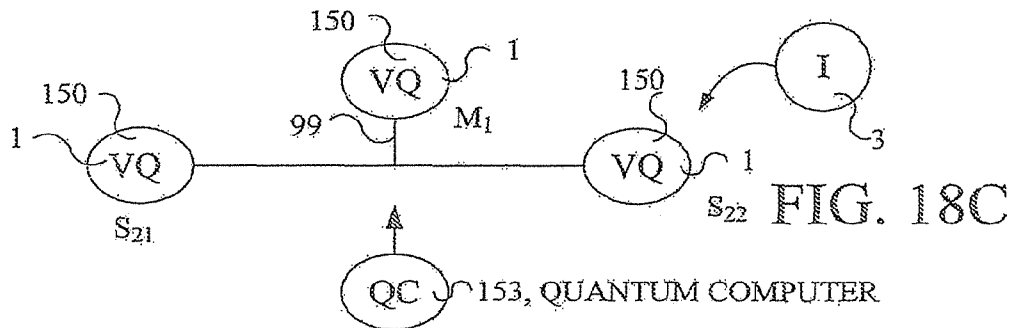

FIG. 18B



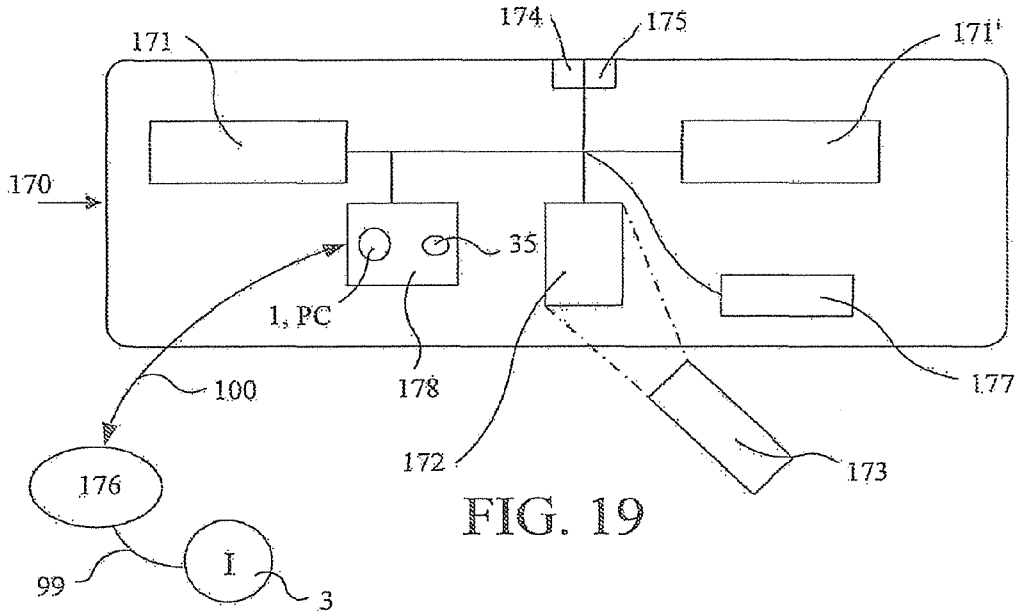

FIG. 19

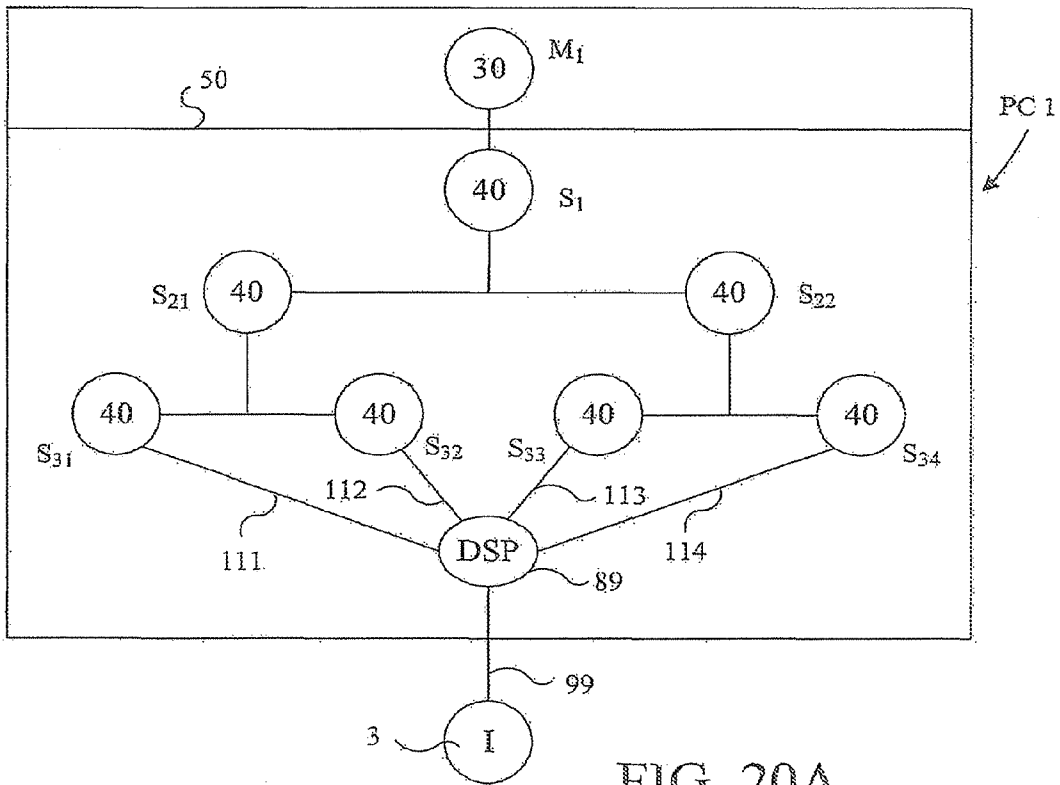

FIG. 20A

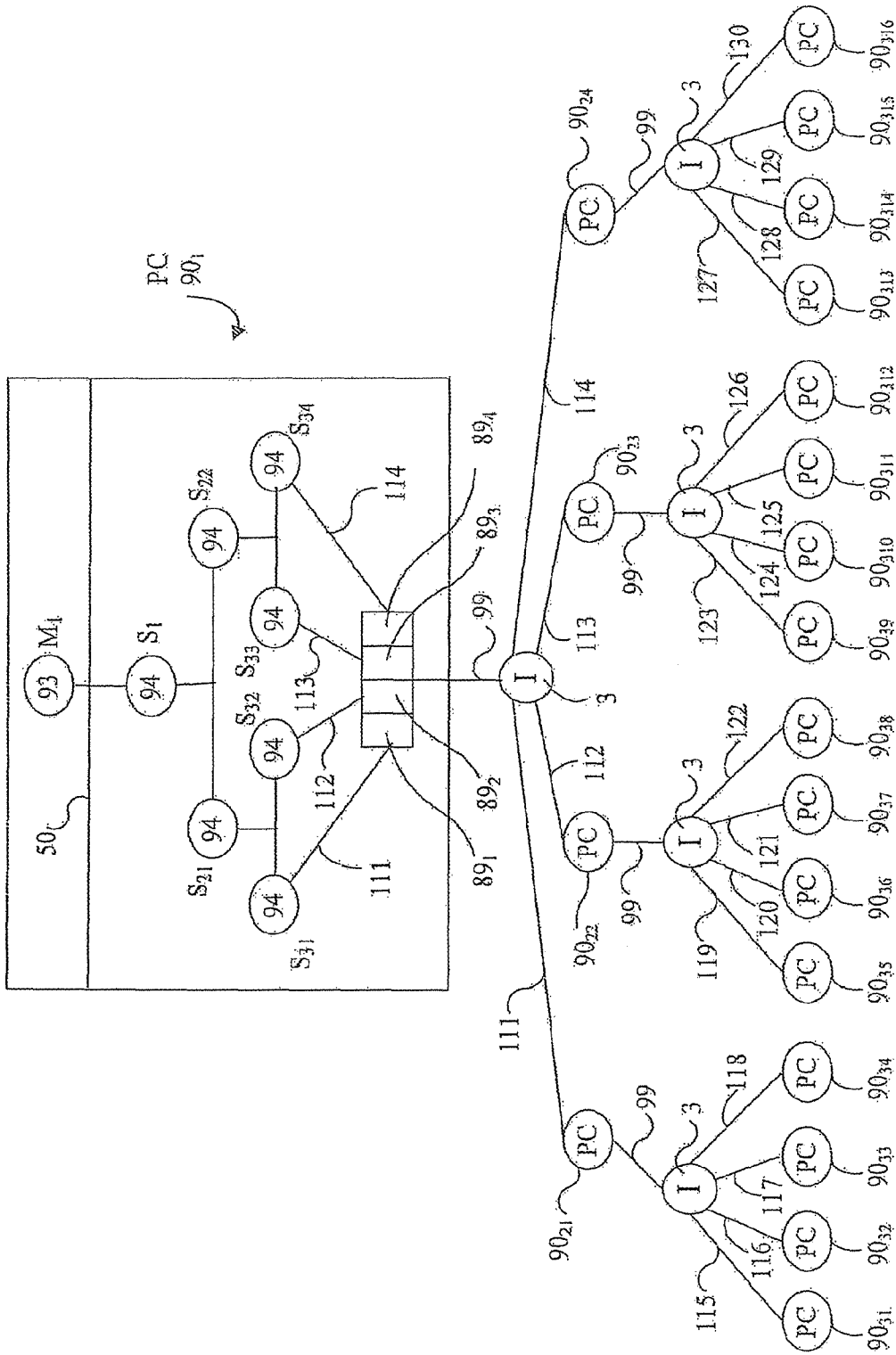

FIG. 20B

FIG. 21A

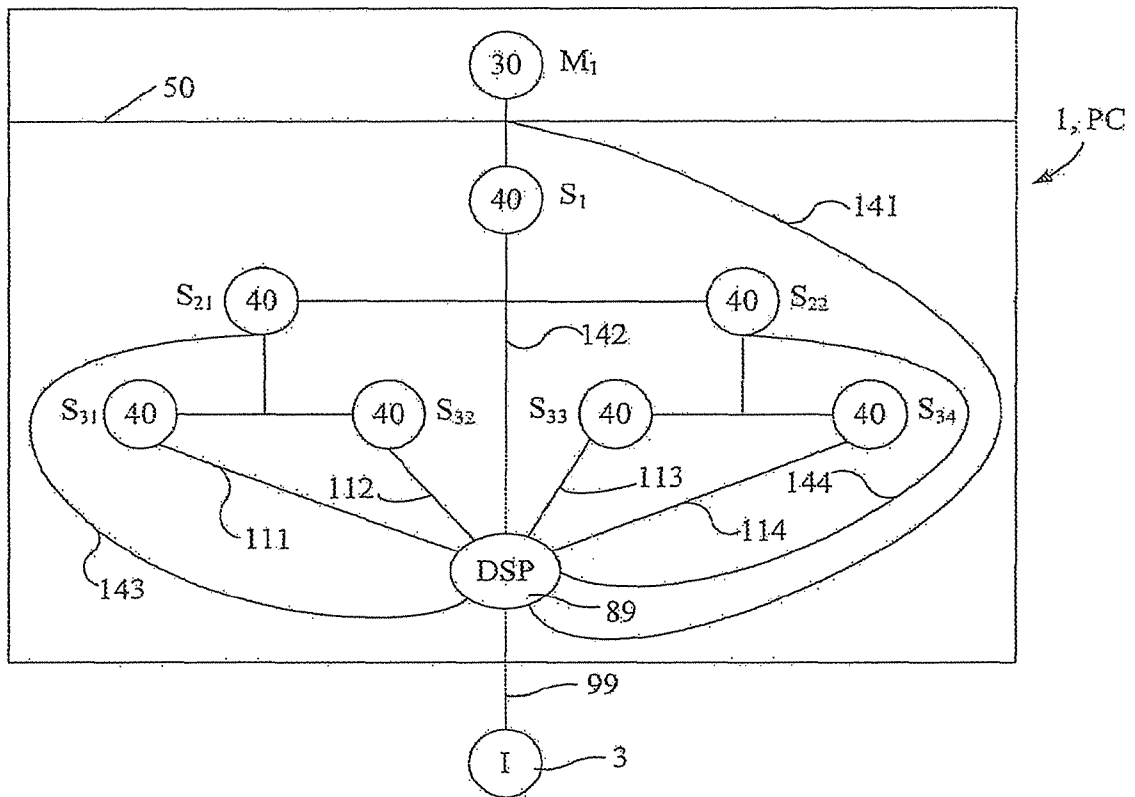
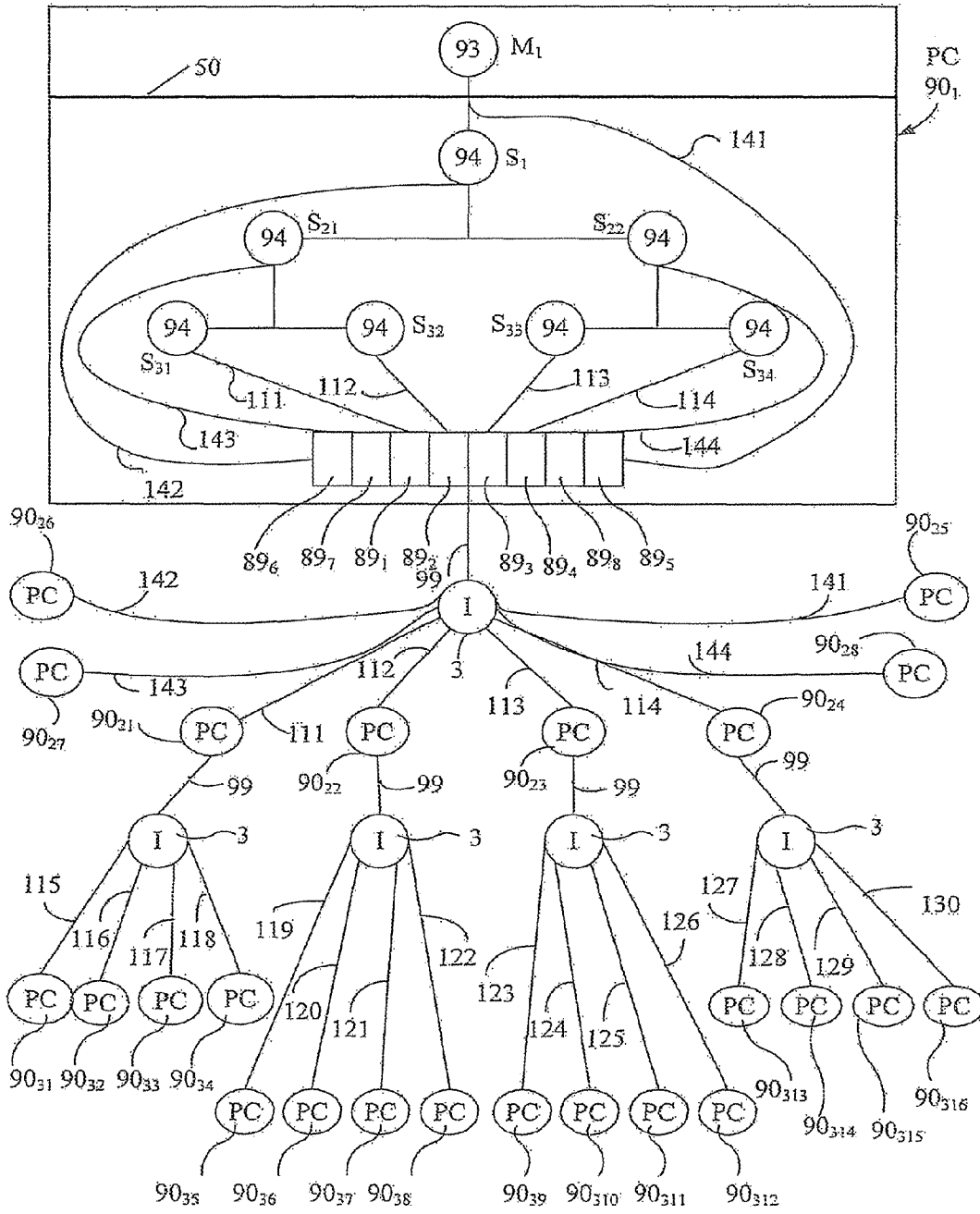

FIG. 21B



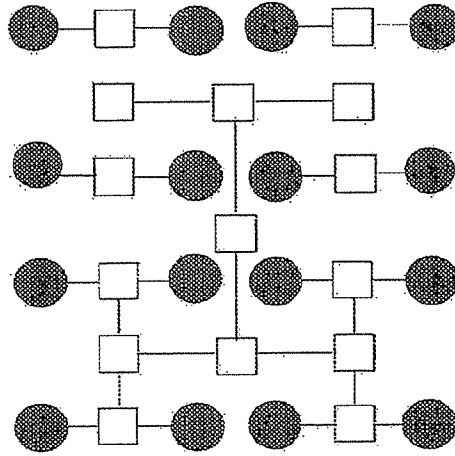

FIG. 21C

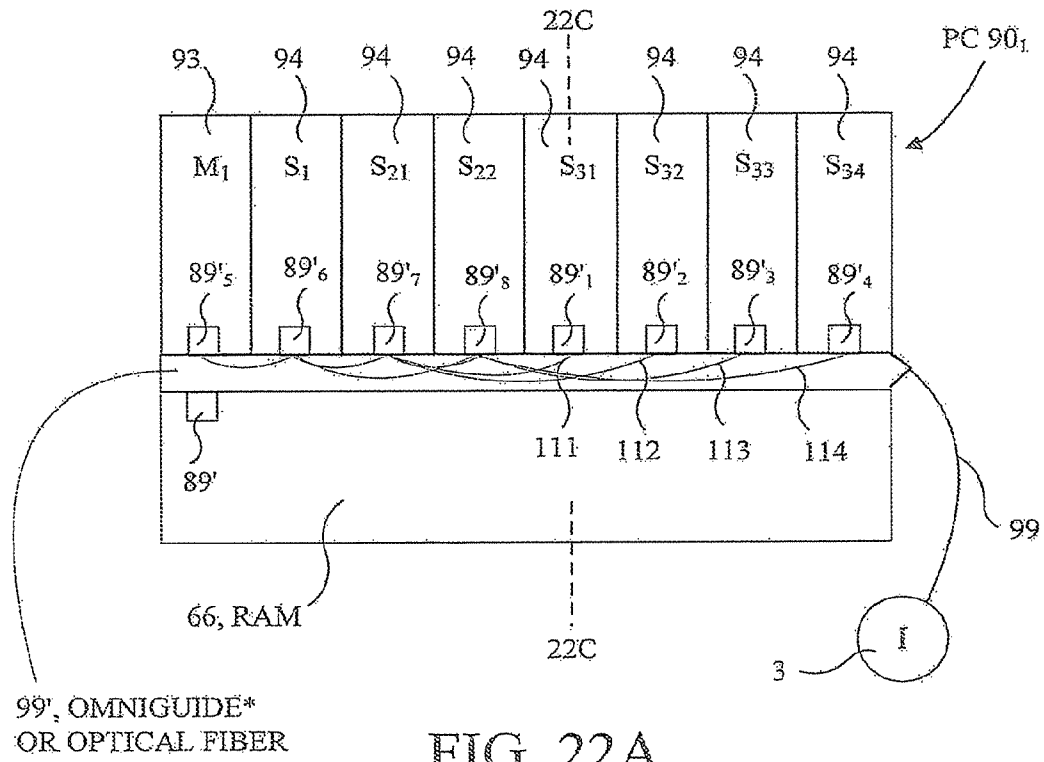

FIG. 22A

FIG. 22B

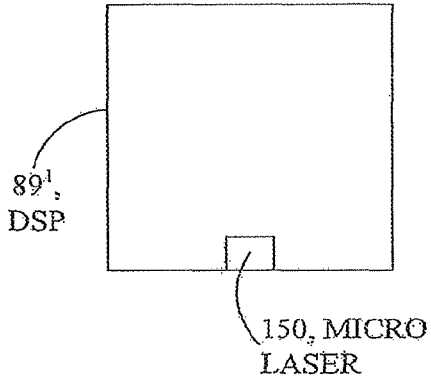

FIG. 22C

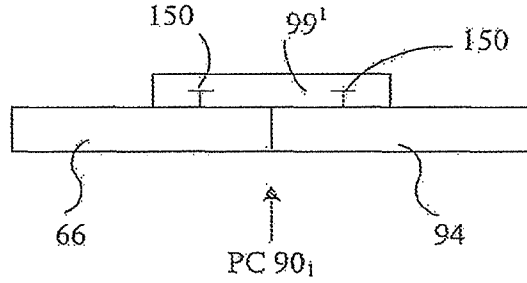

FIG. 23A

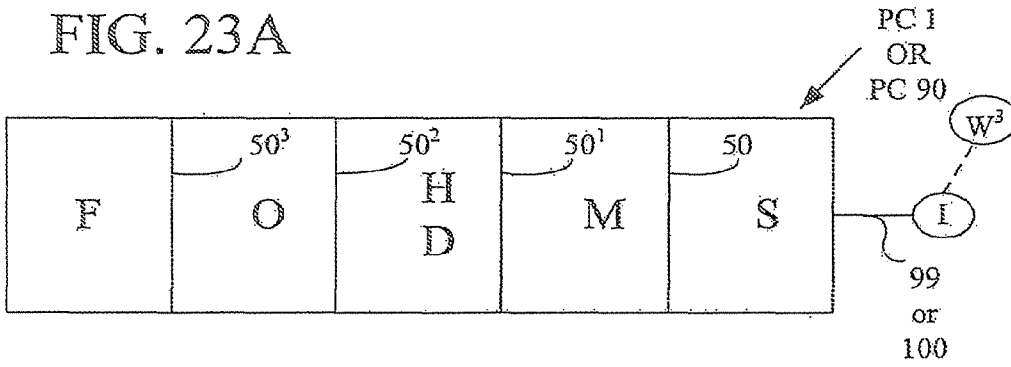

FIG. 23B

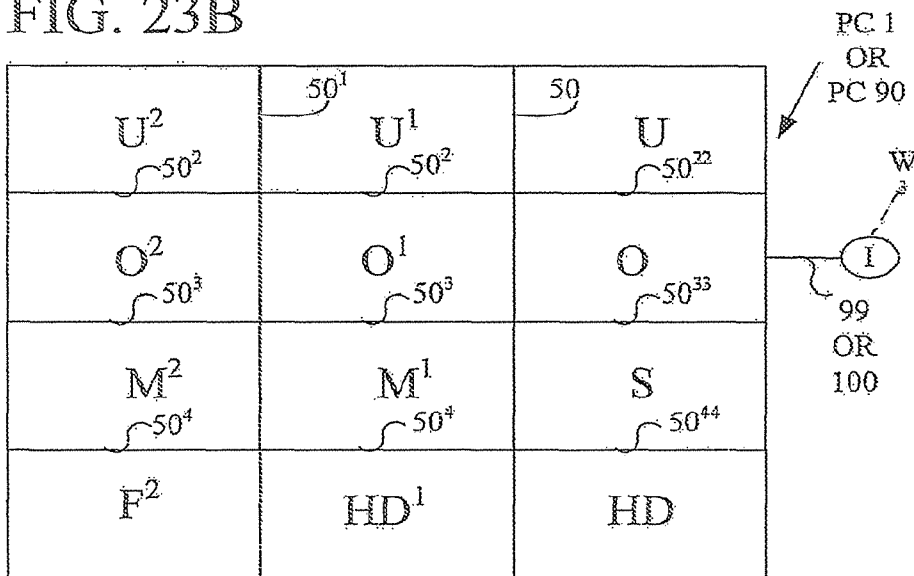

FIG. 23C

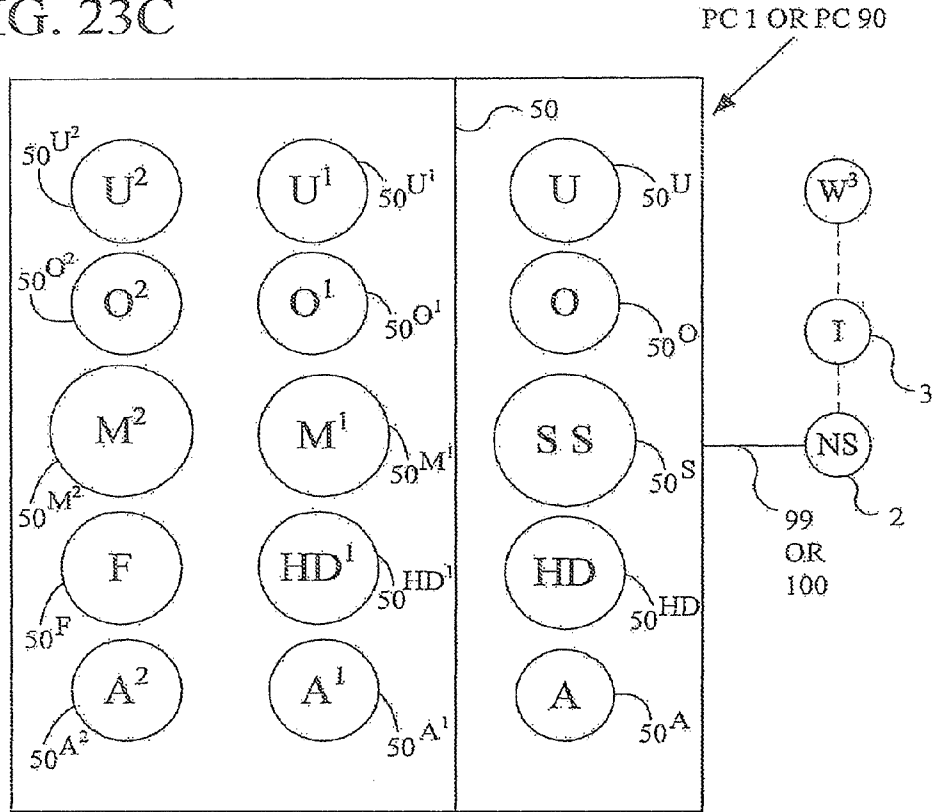

FIG. 23D

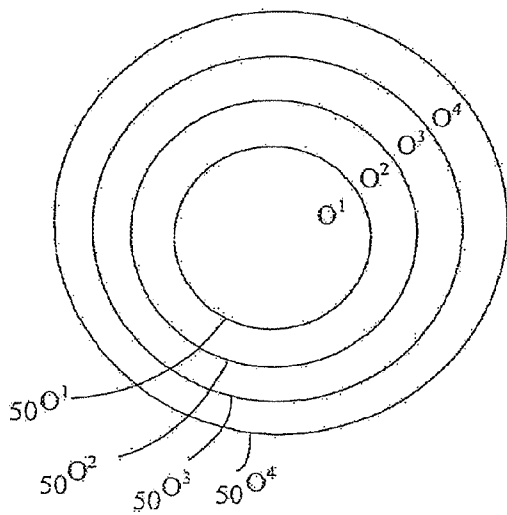

FIG. 23E

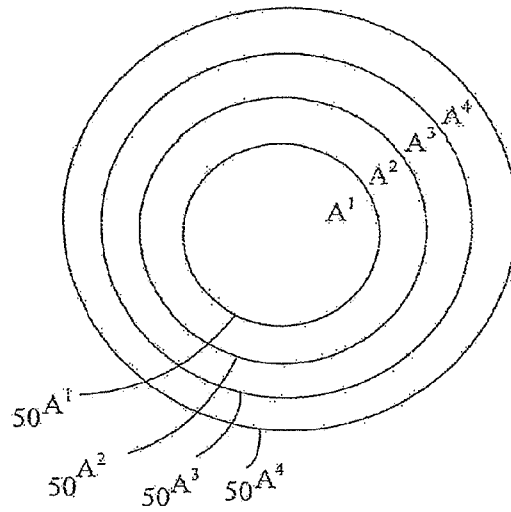

FIG. 24

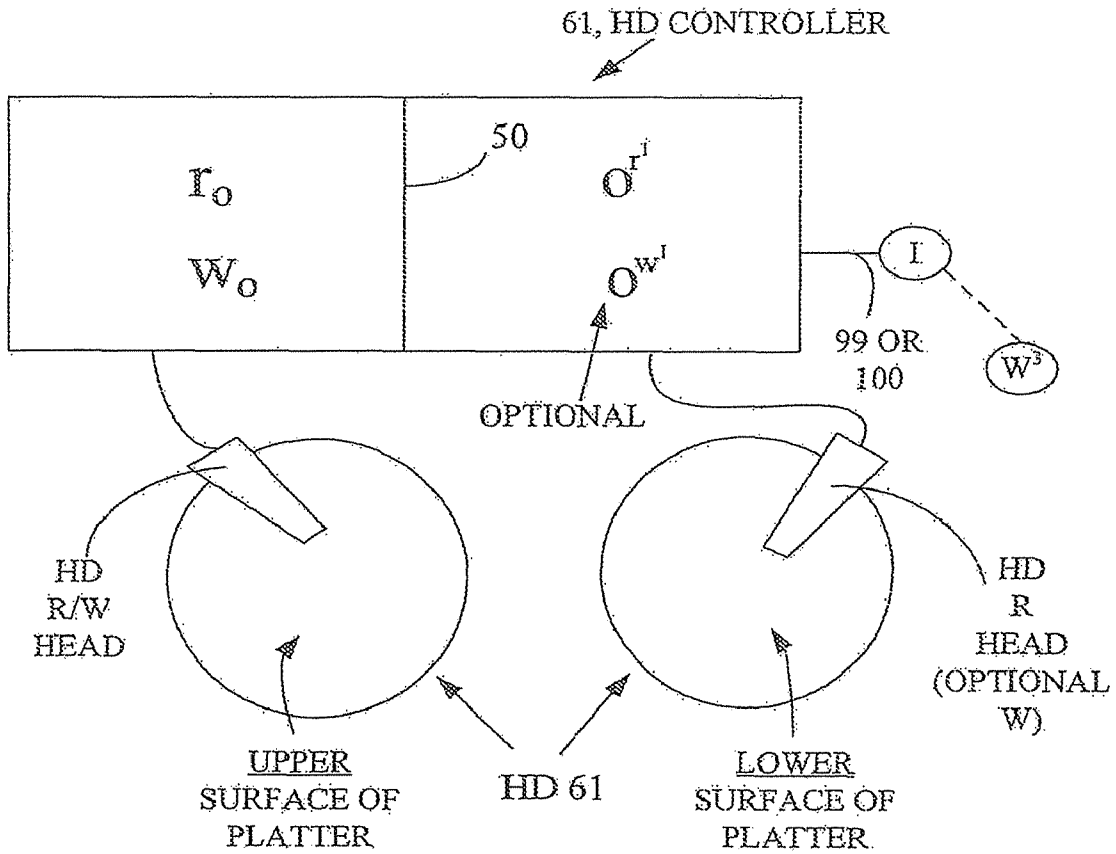

FIG. 25A

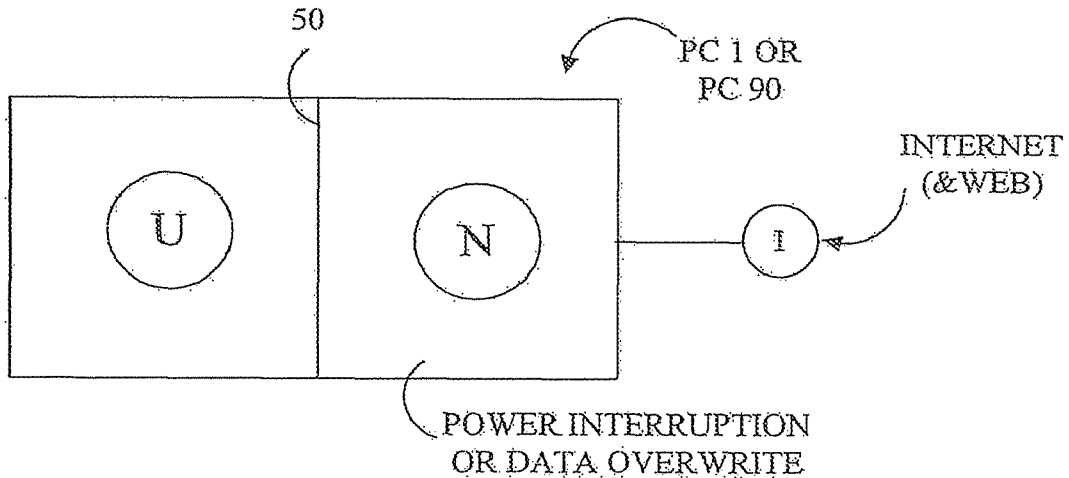

FIG. 25B

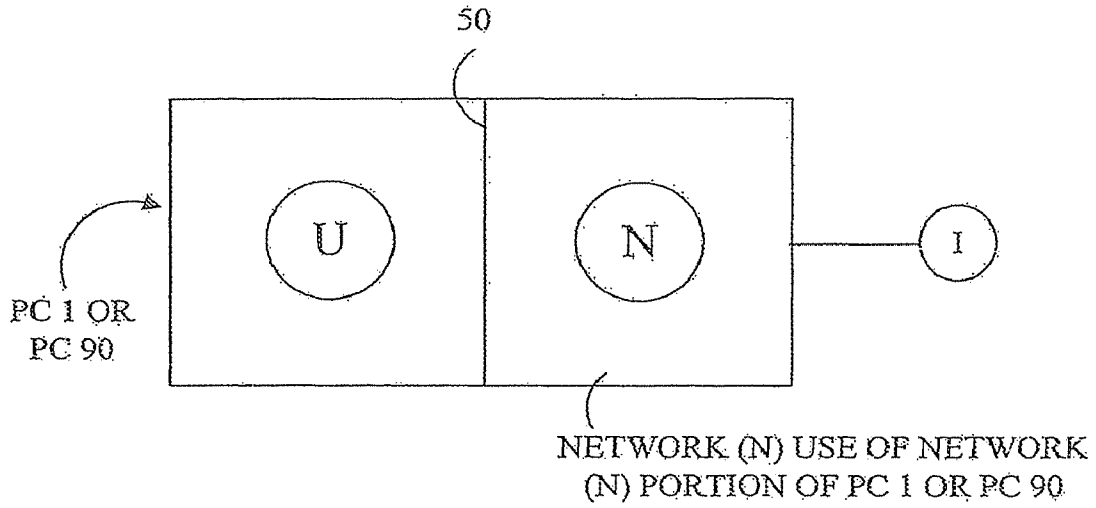

FIG. 25C

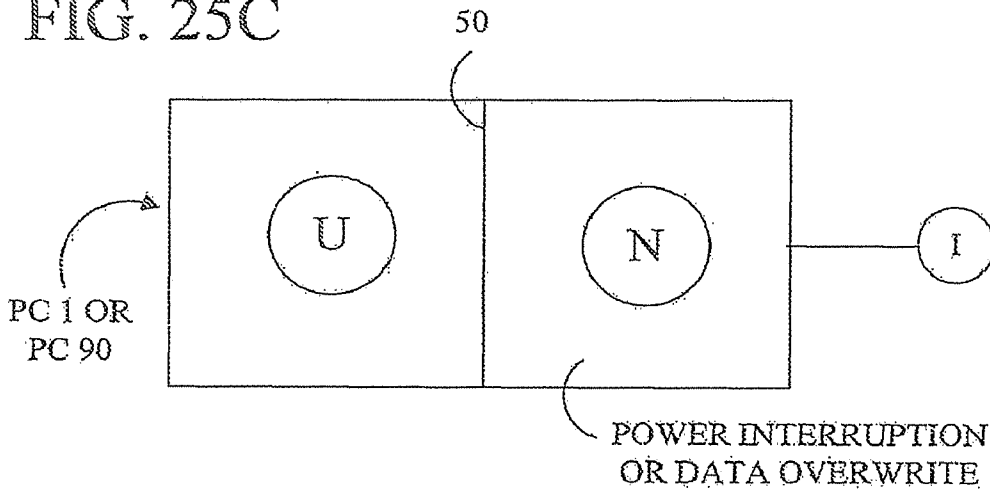

FIG. 25D

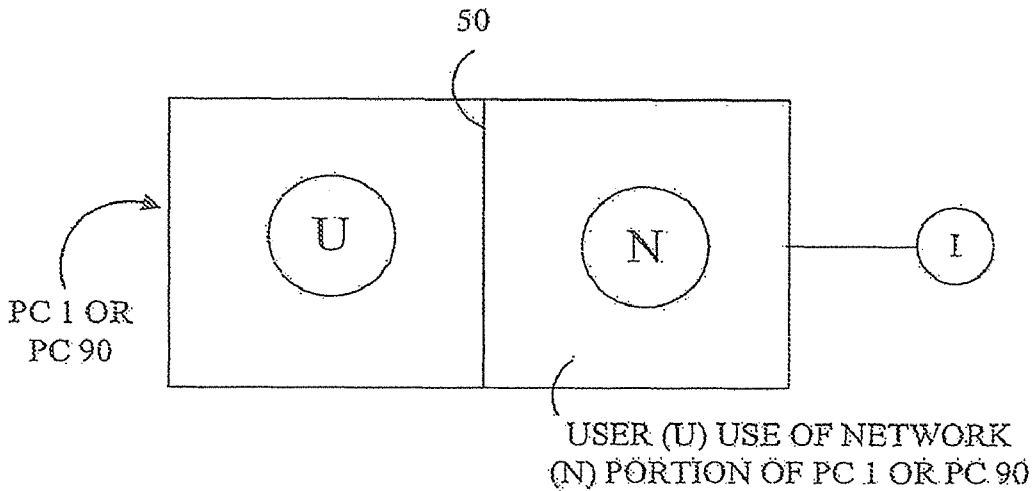

Fig. 26A

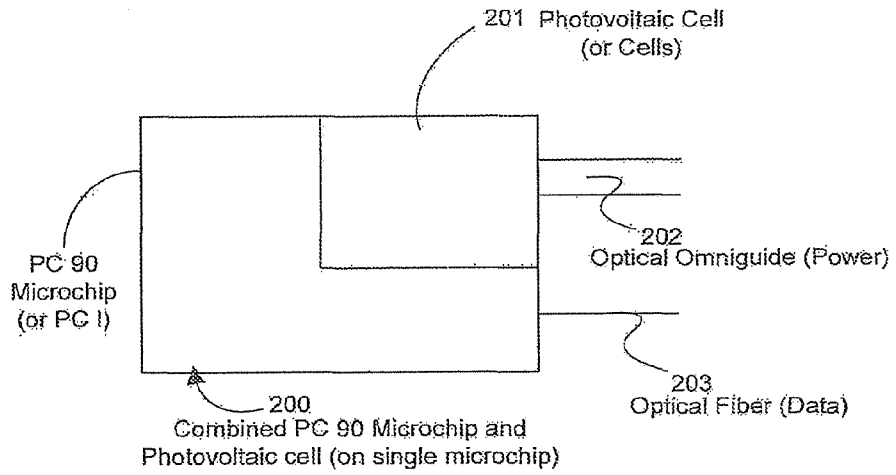

Fig. 26B

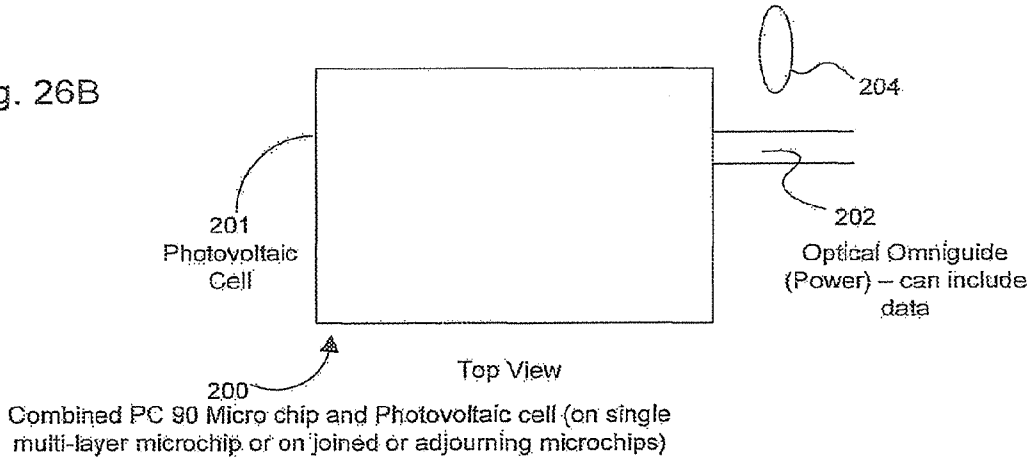
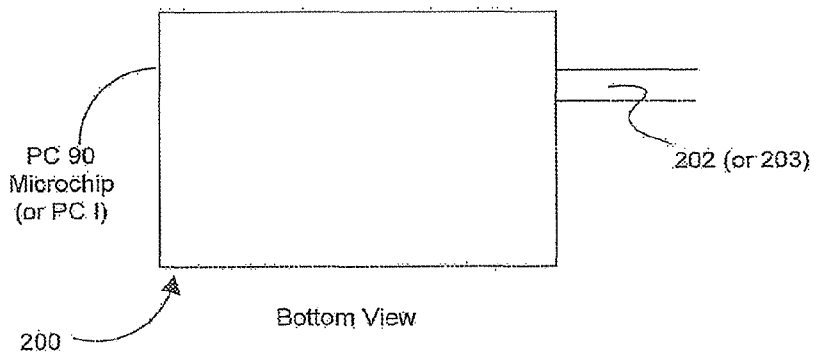
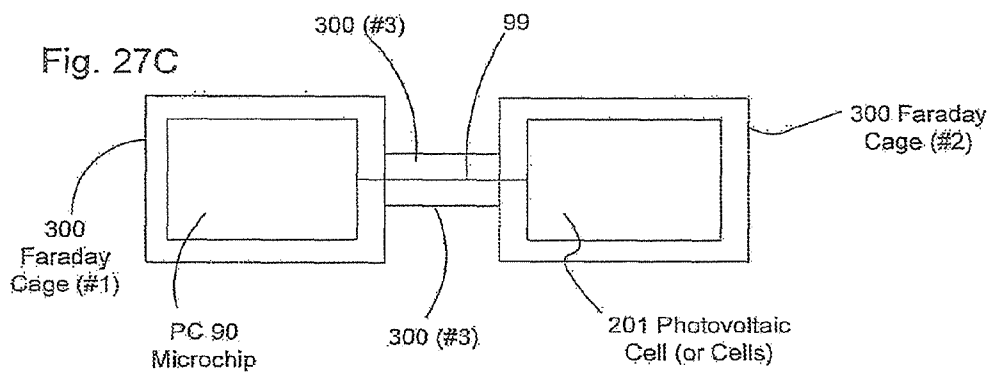
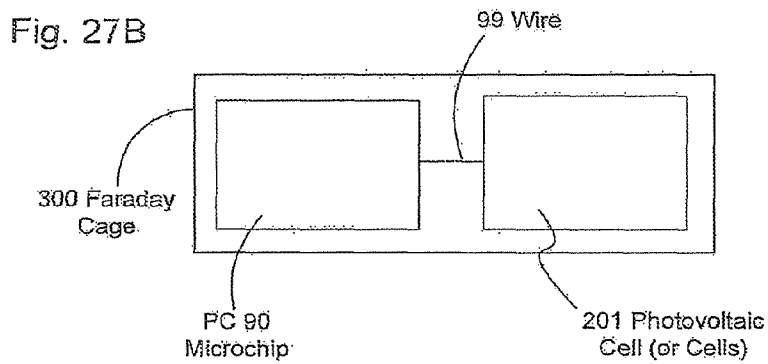
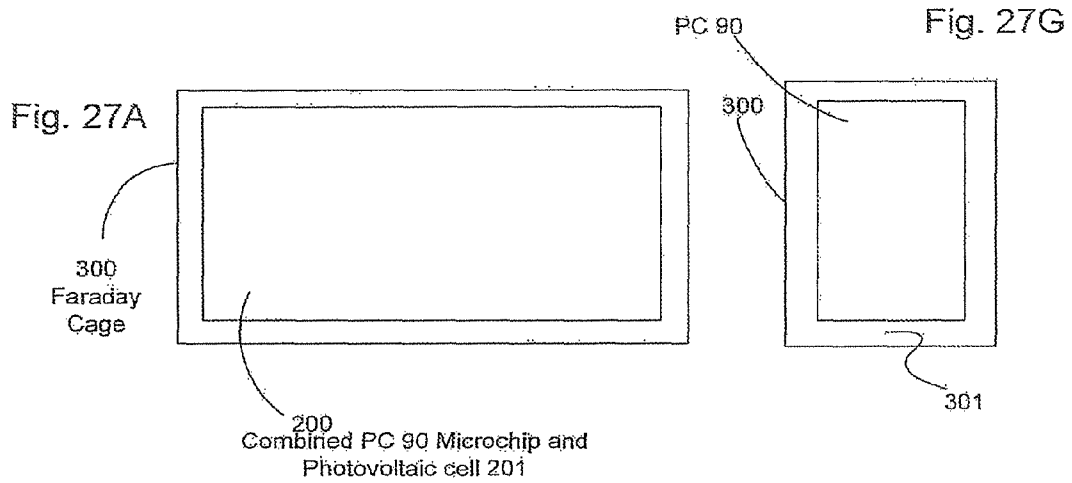

Fig. 26C





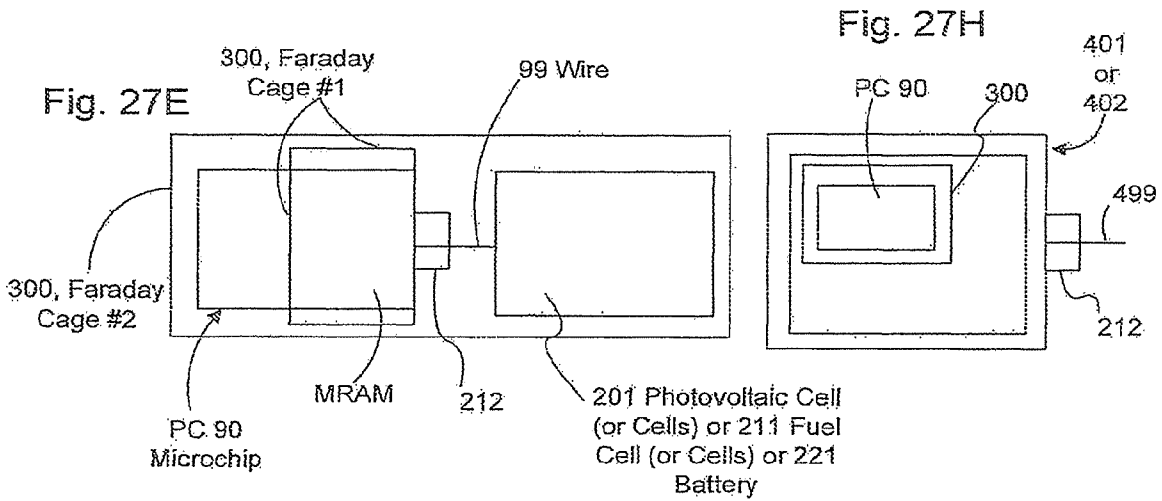
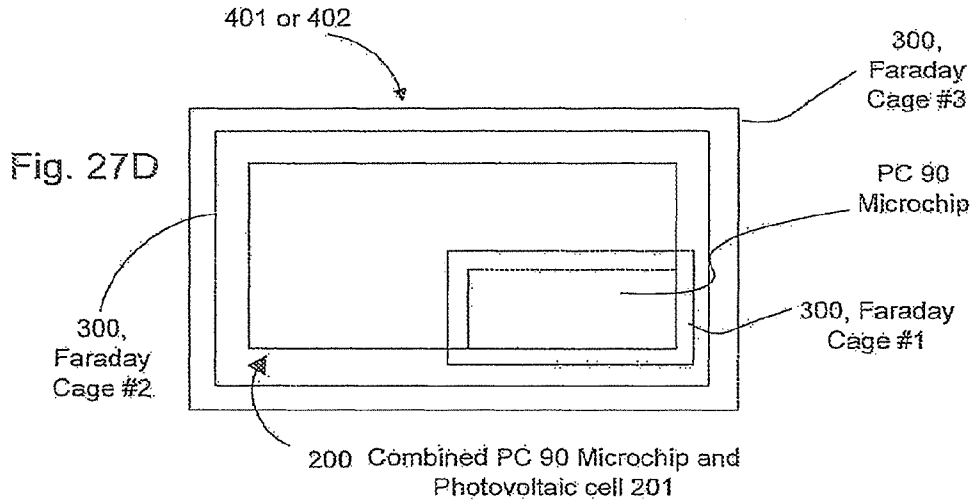

Fig. 27H

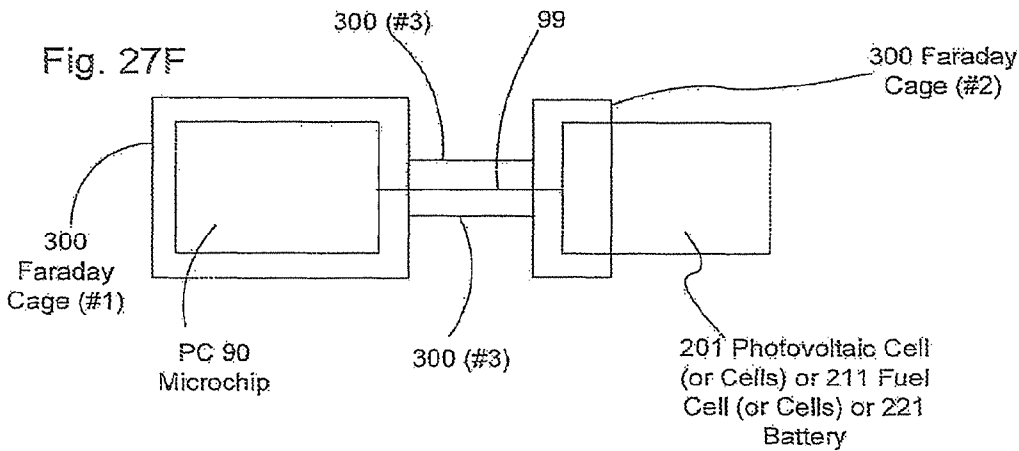

Fig. 28

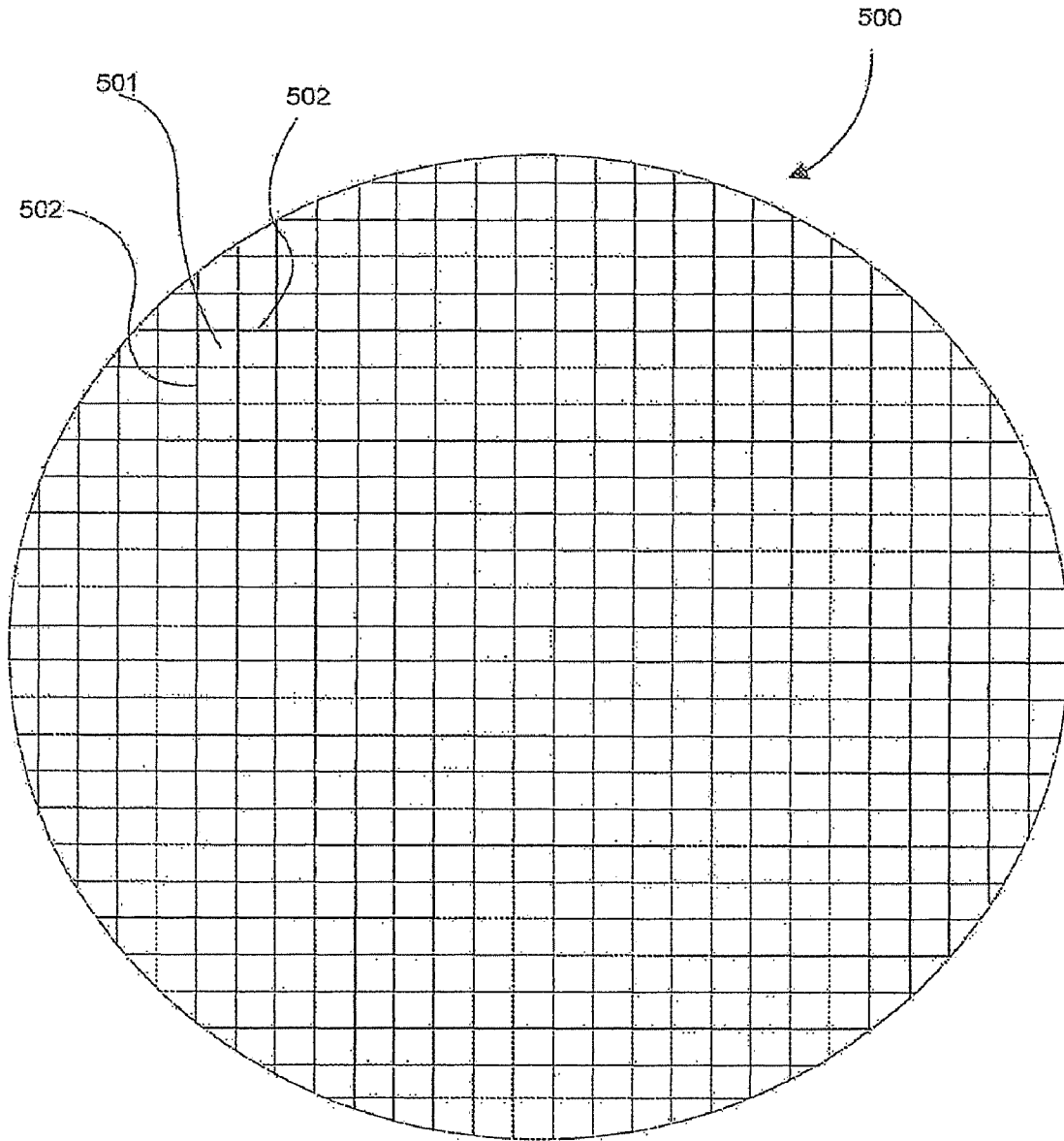

Fig. 29A

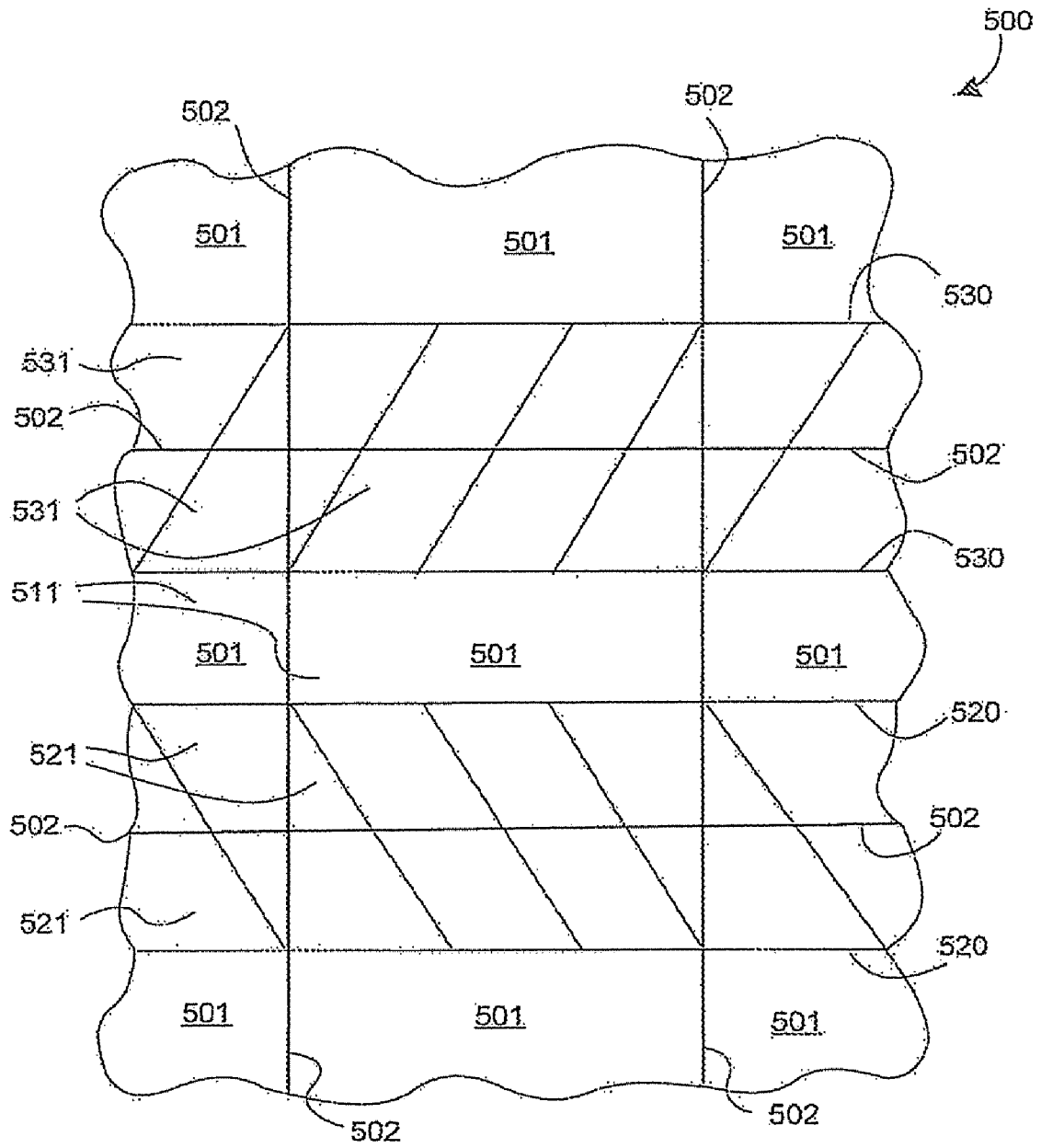

Fig. 29B

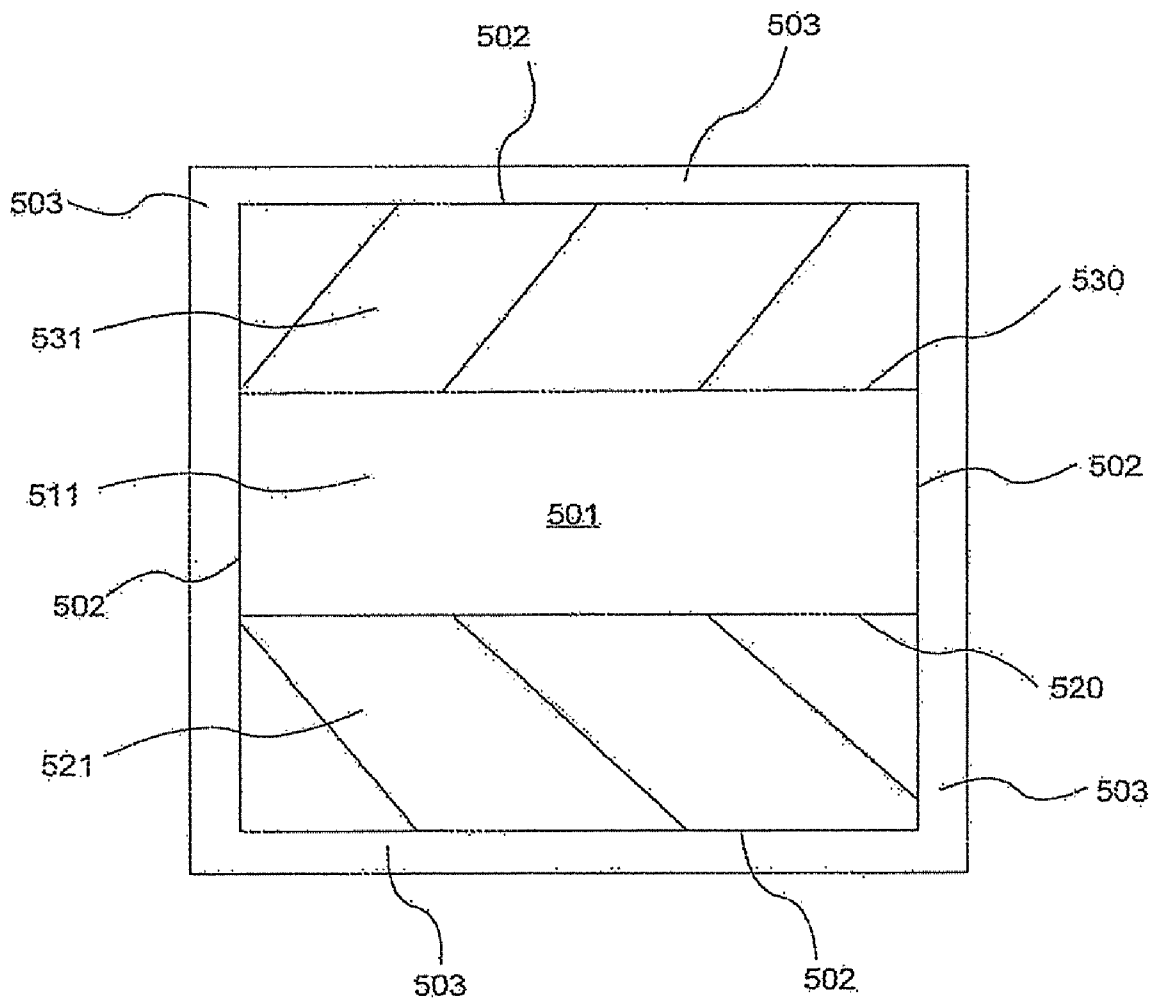

Fig. 30A

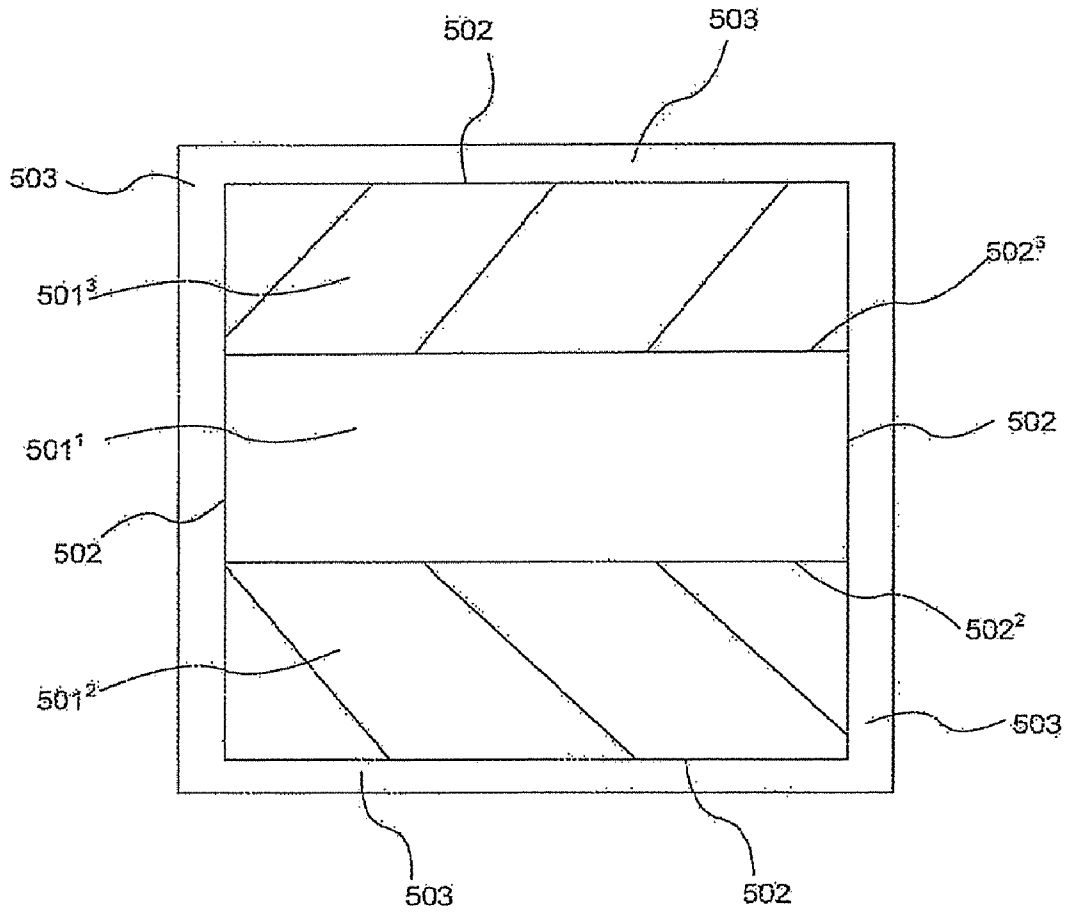

Fig. 30B

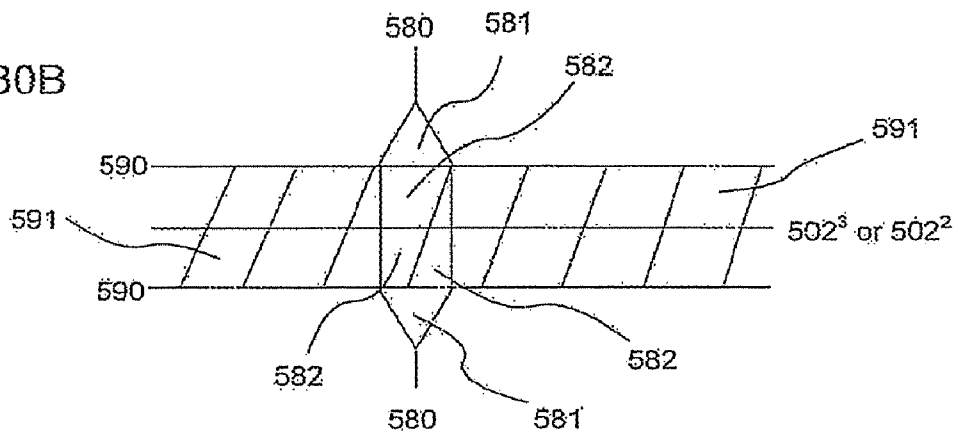
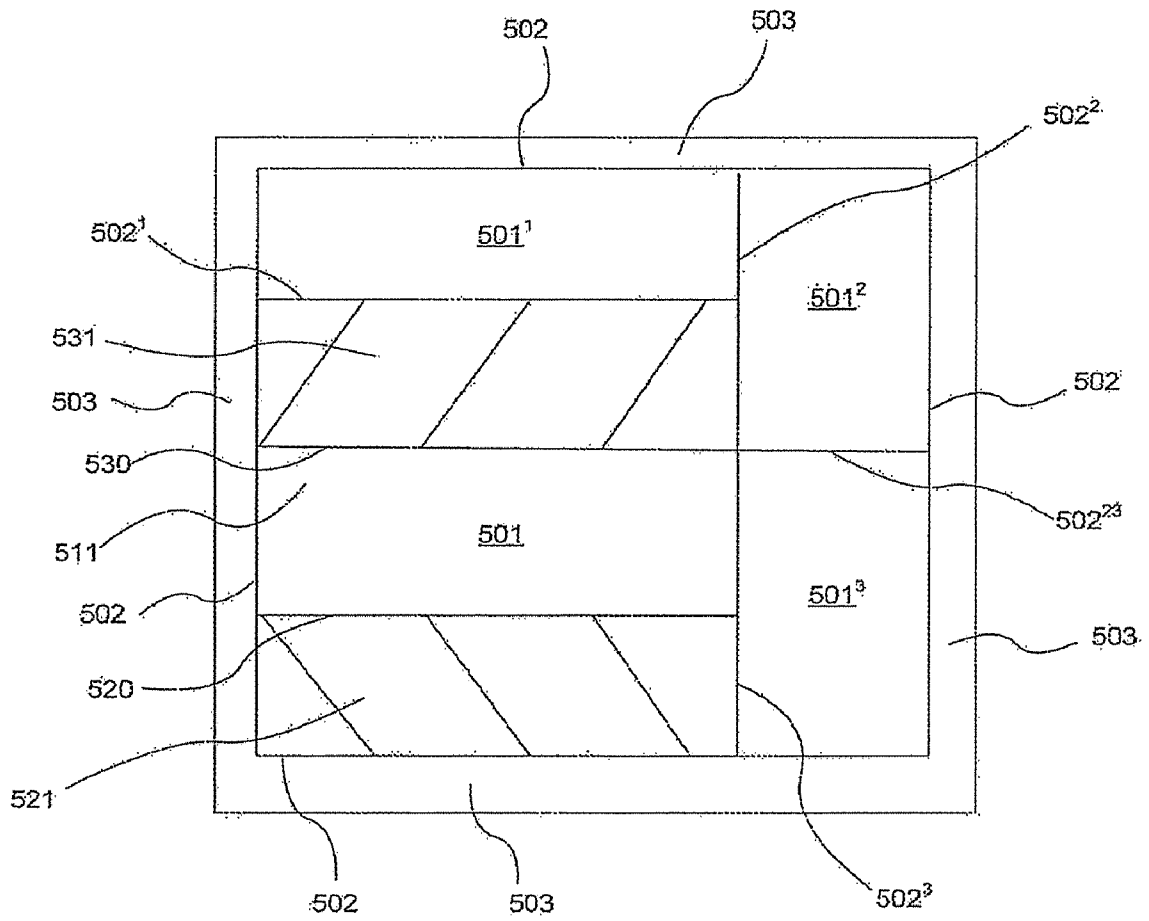

Fig. 30C



Fig. 31



GLOBAL NETWORK COMPUTERS

CROSS REFERENCE TO RELATED APPLICATIONS

This application is a Continuation of U.S. application Ser. No. 12/164,661, filed Jun. 30, 2008, which is a Divisional of U.S. application Ser. No. 10/684,657, now abandoned, U.S. application Ser. No. 10/684,657, receives the benefit of priority from U.S. provisional application 60/418,177, filed Oct. 15, 2002. U.S. application Ser. No. 10/684,657 is a continuation-in-part of U.S. application Ser. No. 09/935,779, filed Aug. 24, 2001, U.S. Pat. No. 7,506,020; and a continuation-in-part of PCT/US02/29227, filed Sep. 16, 2002, which receives the benefit of priority from U.S. provisional application 60/323,701, filed Sep. 21, 2001; and U.S. provisional application 60/322,474, filed Sep. 17, 2001. U.S. application Ser. No. 09/935,779, filed Aug. 24, 2001 receives the benefit of priority from U.S. provisional 60/227,660, filed Aug. 25, 2000; and U.S. provisional application 60/308,826, filed Aug. 1, 2001; and is a continuation-in-part of U.S. application Ser. No. 09/571,558, filed May 16, 2000, U.S. Pat. No. 7,035,906; and a continuation-in-part of U.S. application Ser. No. 09/315,026 filed May 20, 1999, now U.S. Pat. No. 7,024,449; and a continuation-in-part of U.S. application Ser. No. 09/213,875 filed May 17, 1999, U.S. Pat. No. 6,725,250; and a continuation-in-part of U.S. application Ser. No. 09/085,755 filed May 27, 1998. U.S. application Ser. No. 09/571,558, filed May 16, 2000 receives the benefit of priority from U.S. provisional application 60/135,851, filed May 24, 1999; U.S. provisional application 60/135,852, filed May 24, 1999; and U.S. provisional application 60/136,759, filed May 28, 1999; and is a continuation-in-part of U.S. application Ser. No. 09/315,026, filed May 20, 1999, U.S. Pat. No. 7,024,449; and a continuation in part of U.S. application Ser. No. 09/085,755, filed May 27, 1998, U.S. Pat. No. 7,634,529; and a continuation-in-part of U.S. application Ser. No. 09/213,875, filed Dec. 17, 1998, U.S. Pat. No. 6,725,250. U.S. application Ser. No. 09/315,026, filed May 20, 1999 receives the benefit of priority of U.S. provisional application 60/086,588, filed, May 22, 1998; U.S. provisional application 60/086,516, filed May 22, 1998; U.S. provisional application 60/086,948, filed May 27, 1998; U.S. provisional application 60/087,587, filed Jun. 1, 1998; U.S. provisional application 60/088,459, filed Jun. 8, 1998; and U.S. provisional application 60/134,552, filed May 17, 1999; and is a continuation-in-part of U.S. application Ser. No. 09/213,875, filed Dec. 17, 1998, U.S. Pat. No. 6,725,250; a continuation-in-part of PCT application PCT/US97/21812, filed Nov. 28, 1997; and a continuation-in-part of PCT application PCT/US98/27058, filed Dec. 17, 1998, which receives the benefit of U.S. provisional application 60/068,366, filed Dec. 19, 1997. U.S. application Ser. No. 09/213,875, filed Dec. 17, 1998, receives the benefit of priority of U.S. provisional application 60/068,366, filed Dec. 19, 1997; U.S. provisional application 60/086,588, filed May 22, 1998; U.S. provisional application 60/086,516 filed May 22, 1998; U.S. provisional application 60/086,948, filed May 27, 1998; U.S. provisional application 60/087,587, filed Jun. 1, 1998; and U.S. provisional application 60/088,459, filed Jun. 8, 1998; and is a continuation-in-part of 08/980,058, filed Nov. 26, 1997, U.S. Pat. No. 6,732,141. U.S. application Ser. No. 09/085,755, filed May 27, 1998, receives the benefit of priority of U.S. provisional application 60/068,366, filed Dec. 19, 1997; U.S. provisional application 60/086,588, filed May 22, 1998; U.S. provisional application 60/086,516, filed May 22, 1998; U.S. provisional application 60/066,313, filed Nov. 21, 1997; and U.S. provisional application 60/066,415, filed

Nov. 24, 1997; and is a continuation-in-part of U.S. application Ser. No. 08/980,058, filed Nov. 26, 1997, and PCT/US97/21812, filed Nov. 28, 1997. U.S. application Ser. No. 08/980,058, filed Nov. 26, 1997, receives the benefit of priority from U.S. provisional application 60/031,855, filed Nov. 29, 1996; U.S. provisional application 60/032,207, filed Dec. 2, 1996; U.S. provisional application 60/033,871, filed Dec. 20, 1996; U.S. provisional application 60/066,313, filed Nov. 21, 1997; and U.S. provisional application 60/066,415, filed Nov. 24, 1997. All of the above applications and patents are herein incorporated by reference.

BACKGROUND OF THE APPLICATION

This invention relates generally to one or more computer networks that include computers, such as personal computers (PC's) or network computers such as servers, which have microprocessors linked by broadband, transmission means and have hardware, software, firmware, and -other means such that at least two parallel processing operations occur that involve at least two sets of computers in the network or in interconnected networks. This invention constitutes a form of metacomputing.

More particularly, this invention relates to one or more large networks, like the Internet, which comprise smaller networks and large numbers of interconnected computers, wherein multiple separate parallel or massively parallel processing operations involving multiple different sets of computers occur simultaneously. Even more particularly, this invention relates to one or more such networks wherein multiple parallel or massively parallel microprocessing processing operations occur separately or in an interrelated fashion, and wherein ongoing network processing linkages are established between virtually any microprocessors of separate computers connected to the network.

Still more particularly, this invention relates generally to a network structure or architecture that enables the shared use of network microprocessors for parallel processing, including massive parallel processing, and other shared, processing such as multitasking, wherein personal computer owners provide microprocessor processing power to a network, such as for parallel or massively parallel processing or multitasking, in exchange for network linkage to other personal computers and other computers supplied by network providers such as Internet Service Providers (ISP's), including linkage to other microprocessors for parallel or other processing such as multitasking. The financial basis of the shared use between owners and providers may be whatever terms to which the parties agree, subject to governing laws, regulations, or rules, including payment from either party to the other based on periodic measurement of net use or provision of processing power like a deregulated electrical power grid or involving no payment. The network system may provide an essentially equivalent usage of computing resources by both users and providers since any network computer operated by either entity is potentially both a user and provider of computing resources alternately or simultaneously, assuming multitasking is operative. A user may have an override option exercised on the basis of, for example, a user profile, a user's credit line, or relatively instant payment.

This invention also relates to a network system architecture including hardware and software that provides use of the Internet or other network, without cost, to users of personal computers or other computers, while also providing users with computer processing performance that, at least doubles every 18 months through metacomputing means. This metacomputing performance increase provided by the new Grid

(or MetaInternet) is in addition to other performance increases, such as those already anticipated by Moore's Law.

The computer industry has been governed over the last 30 years by Moore's Law, which holds that the circuitry of computer chips shrinks substantially each year, yielding a new generation of chips every 18 months with twice as many transistors, such that microprocessor computing power effectively doubles every year-and-a-half.

The long-term trend in computer chip miniaturization is projected to continue unabated over the next few decades. For example, slightly more than a decade ago a 16 kilobit DRAM (dynamic random access memory) memory chip (storing 16,000 data bits) was typical; the standard in 1996 was the 16 megabit chip (16,000,000 data bits), which was introduced in 1993; industry projections are for 16 gigabit memory chips (16,000,000,000 data bits) to be introduced in 2008 and 64 gigabit chips in 2011; and 16 terabit chips (16,000,000,000,000 data bits) may be conceivable by the mid-to-late 2020's, by which time such microchips may have become nanochips in terms of their circuit dimensions. This is a thousand-fold increase regularly every fifteen years. Hard drive speed and capacity are also growing at a spectacular rate, even higher in recent years than that of semiconductor microchips.

Similarly, regular and enormous improvements may continue in microprocessor computing speeds, whether measured in simple clock speed or MIPS (millions of instructions per second) or numbers of transistors per chip. For example, performance has improved by four or five times every three years since Intel launched its X86 family of microprocessors used in the currently dominant "Wintel" standard personal computers. The initial Intel Pentium Pro microprocessor was introduced in 1995 and is a thousand times faster than the first IBM standard PC microprocessor, the Intel 8088, which was introduced in 1979. By 1996 the fastest of microprocessors, such as Digital Equipment Corporation's Alpha chip, and even the microprocessor of the Nintendo 64 video game system, were faster than the processor in the original Cray Y-MP supercomputer.

Microprocessors, software, firmware, and other components are also evolving from 8-bit and 16-bit systems into the 32-bit systems that are becoming the standard today, with some 64-bit systems like the DEC Alpha already introduced and more coming, such as Intel's Itanium microprocessor in 2001, with future increases, to 128-bit systems likely.

A second major development trend in the past decade or so has been the rise of parallel processing, a computer architecture utilizing more than one CPU microprocessor linked together into a single computer with new operating systems having modifications that allow such an approach. Thousands of relatively simple microprocessors may be used together for massively parallel processing. The field of supercomputing has been overtaken by this approach, which includes designs utilizing many identical standard personal computer microprocessors.

Hardware, firmware, software, and other components specific to parallel processing are in a relatively early stage of development compared to that for single processor computing. Therefore, much further design and development are expected in the future to better maximize the computing capacity made possible by parallel processing. Continued improvement is anticipated in system hardware, software, and architectures for parallel processing so that reliance on the need for multiple microprocessors to share a common central memory is reduced, thereby allowing more independent operation of those general purpose microprocessors, each with their own discrete memory, like current personal computers, workstations, and most other computer systems

architecture. For unconstrained operation, each individual microprocessor should have rapid access to sufficient memory.

Several models of personal computers having more than one general purpose microprocessor are now available. In the future, personal computers, broadly defined to include versions not currently in use, will likely also employ parallel computing utilizing multiple microprocessors or massively parallel computing with very large numbers of microprocessors. Future designs, such as Intel's Itanium chip, are expected to have a significant number of parallel processors on a single microprocessor chip.

A form of parallel processing called superscalar processing is also being employed within microprocessor design. The current generation of microprocessors, such as the Intel Pentium, have more than one data path within the microprocessor in which data is processed, with two to three paths being typical now and as many as eight in 1998 in IBM's new Power 3 microprocessor chip.

A third major development trend is the increasing size of bandwidth, which is a measure of communications power or transmission speed, in terms of units of data per second, between computers connected by a network. Previously, the local area networks and telephone lines typically linking computers including personal computers have operated at speeds much lower than the processing speeds of a personal computer. For example, a typical 1997 Intel Pentium operates at 100 MIPS, whereas the most common current Ethernet connecting PC's is roughly 10 times slower at 10 megabits per second (Mbps), although some Ethernet connections are now 100 Mbps and telephone lines are very much slower, the highest typical speed in 1998 being the approximately 56 kilobits reached during downloads.

The situation is expected to change dramatically. Bandwidth or transmission speed is anticipated to expand from 5 to 100 times as fast as the rise of microprocessor speeds, due to the use of coaxial cable, wireless, and especially fiber optic cable and optical wireless, instead of old telephone twisted pair lines, and due to the use of wideband communication such as dense wave division multiplexing (DWDM) and wideband code division multiple access (CDMA), as well as ultrawideband wireless. In DWDM systems, multiple channels are transmitted over a single fiber because they are sent at different wavelengths. Telecommunication providers are now making available single fiber connections supporting a bandwidth of 40 gigabits per single fiber, and, alternatively, as many as 160 wavelength channels (lambdas) per single fiber. In CDMA systems, users are multiplexed across the same spectrum, with each user being assigned a different instance of a noise-like carrier wave.

Technical improvements are expected in the near term which will make it possible to carry over 2 gigahertz (billions of cycles per second) on each of 700 wavelength channels (lambdas), adding up to more than 1,400 gigahertz on a single fiber thread. Experts have estimated that the bandwidth of optical fiber has been utilized one million times less fully than the bandwidth of coaxial or twisted pair copper lines. Within a decade, 10,000 wavelength streams per fiber are expected; 20 to 80 wavelengths on a single fiber is already commercially available. The use of thin mirrored hollow wires or tubes called omniguides may also provide very substantial additional increases.

Other network connection developments, such as asynchronous transfer mode (ATM) and digital signal processors, whose price/performance ratio has improved tenfold every two years, are also supporting the rapid increase in bandwidth. The increase in bandwidth reduces the need for switch-

ing, and switching speed will be greatly enhanced when practical optical switches are introduced in the near future, potentially reducing costs substantially.

The result of this huge bandwidth increase, is extraordinary: already it is technically possible to connect virtually any computer to a network with a bandwidth that equals or exceeds the computer's own internal system bus speed, even as that bus speed itself is increasing significantly. The principal constraint is the infrastructure, consisting mostly of connecting the "last mile" to personal computers with optical fiber or other broad bandwidth connections, which still need to be built. The system bus, of a computer is its internal network connecting many or most of its internal components such as microprocessor, random access memory (RAM), hard drive, modem, floppy drive, and CD-ROM; for recent personal computers, the system bus has been only about 40 megabits per second, but is up to 133 megabits per second on Intel's Pentium PCI bus in 1995. IBM's 1998 Power3 microprocessor chip has a system bus of 1.6 gigabits per second and there is now up to a gigabit per second on Intel's Pentium PCI bus.

Despite these tremendous improvements anticipated in the future, a typical PC is already so fast that its microprocessor is essentially idle during most of the time the PC is in actual use, and the operating time itself is but a small fraction of those days the PC is even in use at all. Nearly all PC's are essentially idle during roughly all of their useful life. A microprocessor of a PC may be in an idle state 99.9% of the time, disregarding unnecessary microprocessor busywork such as executing screen saver programs, which have been made essentially obsolete by power-saving CRT monitor technology, which is now standard in the PC industry.

Because the reliability of PC's is so exceptionally high now, with the mean time to failure of all components typically several hundred thousand hours or more, the huge idle time of PC's represents a total loss; given the high capital and operating costs of PC's, the economic loss is very high. PC idle time does not in effect store a PC, saving it for future use, since the principle limiting factor to continued use of today's PC's is obsolescence, not equipment failure resulting from use.

Moreover, there is continuing concern that Moore's Law, which holds that the constant miniaturization of circuits results in a doubling of computing power every 18 months, cannot continue to hold true much longer. Indeed, Moore's Law may now be nearing its limits for silicon-based devices, perhaps by as early as 2010. No new technologies have yet emerged that seem to have the potential for development to a practical level by then, although many recent advances have the potential to maintain Moore's Law.

SUMMARY OF THE INVENTION

However, the confluence of all three of the established major trends summarized above—supercomputer-like personal computers, the spread of parallel processing using personal computer general purpose microprocessors (particularly massively parallel processing), and the enormous increase in network communications bandwidth—enables a solution to the excessive idleness problem of personal computers and the possible end of Moore's Law. The solution may achieve very high potential economic savings once the basic infrastructure connecting personal computers with optical fiber is in place in the relatively near future.

The solution is to use those mostly idle PC's (or their equivalents or successors) to build a parallel or massively parallel processing computer or computers utilizing a very

large network, like the Internet or, more specifically, like the World Wide Web (WWW), or their equivalents or eventual successors like the Grid or MetaInternet (and including Internet II and the Next Generation Internet, which are under development now and which will utilize much broader bandwidth and will coexist with the Internet, the structure of which is in ever constant hardware and software upgrade and including the SuperInternet based on essentially all optical fiber transmission) with extremely broad bandwidth connections and virtually unlimited data transmission speed.

A prime characteristic of the Internet is the very large number of computers of all sorts already linked thereto, with the future potential for an effectively universal connection. The Internet is a network of networks of computers that provides nearly unrestricted access worldwide. The currently existing and soon-to-be widely available very broad bandwidth of network communications is used to link personal computers externally in a manner at least equivalent to, and probably much faster than, the faster internal system buses of the personal computers, so that no external processing constraint is imposed on linked personal computers by data input, output, or throughput; the speed of the microprocessor itself and the internal connections or buses of the PC are the only processing constraint of the system.

This makes possible efficient external parallel processing (and multitasking), including massively parallel processing, in a manner paralleling more conventional internal parallel processing, called superscalar processing.

In one embodiment, the World Wide Web is transformed into a huge virtual massively parallel processing computer or computers, with potential through its established hyperlinks connections to operate in a manner at least somewhat like a neural network or neural networks, since the speed of transmission in the broadband linkages is so great that any linkage between two microprocessors is virtually equivalent to direct, physically close connections between those microprocessors.

With further development, digital signal processor-type microprocessors and/or analogue microprocessors may be particularly advantageous, for this approach, either alone or in conjunction with conventional microprocessors and/or the new microprocessors described below. Networks with WWW-type hyperlinks incorporating digital signal processor-type microprocessors could operate separately from networks of conventional microprocessors or with one or more connections between such differing networks or with relatively complete integration between such differing networks. Simultaneous operation across the same network connection structure should be possible, employing non-interfering transmission links.

Such extremely broad bandwidth networks of computers enable every PC within the network to be fully utilized or nearly so. Because of the extraordinary extent to which existing PC's are currently idle, at optimal performance this new system may result in a thousand-fold increase in computer power available to each and every PC user, and, on demand, almost any desired level of increased power, limited mostly by increased cost, which however are relatively far less than possible from other conceivable computer network configurations. This revolutionary increase is in addition to the extremely rapid, but evolutionary increases already occurring in the computer/network industry; as discussed above.

The metacomputing hardware and software means of the Grid (or MetaInternet) provides performance increases that are likely to at least double every eighteen months based on the doubling of personal computers shared in a typical parallel processing operation by a standard PC user, starting first with at least 2 PC's; then about 4, about 8, about 16, about 32,

about 64, about 128, about 256, and about 512, for example. After about fifteen years, for example, it is anticipated that each standard PC user will likely be able to use a maximum of about 1,024 personal computers for parallel processing or any other shared computing use, while generally using for free the Internet or its successors, like the Grid (or MetaInternet). At the other end of the performance spectrum, supercomputers experience a similar performance increase generally, but ultimately the performance increase is limited primarily by the cost of adding network linkages to available PC's, so there is definite potential for a huge leap in supercomputer performance.

Network computer systems as described above offer almost limitless flexibility due to the abundant supply of heretofore idle connected microprocessors. This advantage allows "tightly coupled" computing problems, which normally are difficult to process in parallel, to be solved without knowing in advance how many processors are available (as is now necessary in relatively massively parallel processing), what they are, and their connection characteristics. A minimum number of equivalent processors (with equivalent other specifications) are easily found nearby in a massive network like the Internet and assigned within the network from those multitudes available nearby. Moreover, the number of microprocessors used are almost completely flexible, depending on the complexity of the problem, and limited only by cost. The existing problem of time delay is solved largely by the widespread introduction of broad bandwidth connections between computers processing in parallel.

The state of the known art relating to this application is summarized in *The Grid: Blueprint for a New Computing Infrastructure*, edited by Ian Foster and Carl Kesselman, and published by Morgan Kaufman Publishers, Inc. in 1998. The state of the known art relating to this application is also summarized in: *Scalable Parallel Computing* by Kai Hwang and Zhiwei Xu, published by WCB McGraw-Hill in 1998; *Parallel Programming* by Barry Wilkinson and Michael Allen, published by Prentice Hall in 1998; *Computer Architecture: A Quantitative Approach* (2nd Edition) by David Patterson and John Hennessy, published by Morgan Kaufmann in 1996; *Parallel Computer Architecture* by David Culler and Jaswinder Singh, published by Morgan Kaufman in 1998; and *Computer Organization and Design* by John Hennessy and David Patterson, published by Morgan Kaufman in 1998.

BRIEF DESCRIPTION OF THE DRAWINGS

FIG. 1 is a simplified diagram of a section of a computer network, such as the Internet, showing an embodiment of a meter means which measures flow of computing during a shared operation such as parallel processing between a typical PC user and a network provider.

FIG. 2 is a simplified diagram of a section of a computer network, such as the Internet, showing an embodiment of another meter means which measures the flow of network resources, including shared processing, being provided to a typical PC user and a network provider.

FIG. 3 is a simplified diagram of a section of a computer network, such as the Internet, showing an embodiment of another meter means which, prior to execution, estimates the level of network resources, and their cost, of a shared processing operation requested by a typical PC user from a network provider.

FIGS. 4A-4C are simplified diagrams of a section of a computer network, such as the Internet, showing in a sequence of steps an embodiment of a selection means

whereby a shared processing request by a PC is matched with a standard preset number of other PC's to execute a shared operation.

FIGS. 5A and 5B are simplified diagrams of a section of a computer network, such as the Internet, showing embodiments of a control means whereby the PC, when idled by its user, is made available to the network for shared processing operations.

FIG. 6 is a simplified diagram of a section of a computer network, such as the Internet, showing an embodiment of a signal means whereby the PC, when idled by its user, signals its availability to the network for shared processing operations.

FIG. 7 is a simplified diagram of a section of a computer network, such as the Internet, showing an embodiment of a receiver and/or interrogator means whereby the network receives and/or queries the availability for shared processing status of a PC within the network.

FIG. 8 is a simplified diagram of a section of a computer network, such as the Internet, showing an embodiment of a selection and/or utilization means whereby the network locates available PC's in the network that are located closest to each other for shared processing.

FIG. 9 is a simplified diagram of a section of a computer network, such as the Internet, showing an embodiment of a system architecture for conducting a request initiated by a PC for a search using parallel processing means that utilizes a number of networked PC's.

FIGS. 10A-10I are simplified diagrams of a section of a computer network, such as the Internet, showing an embodiment of a system architecture utilizing an internal firewall to separate that part of a networked PC (including a system reduced in size to a microchip) that is accessible to the network for shared processing from a part that is kept accessible only to the PC user; also showing the alternating role that each PC in the network may play as either a master or slave in a shared processing operation involving one or more slave PC's in the network; and showing a home or business network system which can be configured as an Intranet; in addition, showing PC and PC microchips controlled by a controller (including remote) with limited or no processing capability; and showing PC and PC microchips in which an internal firewall 50 can be reconfigured by a PC user.

FIG. 11 is a simplified diagram of a section of a computer network, such as the Internet, showing an embodiment of a system architecture for connecting clusters of PC's to each other by wireless means, to create the closest possible (and therefore fastest) connections.

FIG. 12 is a simplified diagram of a section of a computer network, such as the Internet, showing an embodiment of a system architecture, for connecting PC's to a satellite by wireless means.

FIG. 13 is a simplified diagram of a section of a computer network, such as the Internet, showing an embodiment of a system architecture providing a cluster of networked PC's with complete interconnectivity by wireless means.

FIG. 14A is a simplified diagram of a section of a computer network, such as the Internet, showing an embodiment of a transponder means whereby a PC can identify one or more of the closest available PC's in a network cluster to designate for shared processing by wireless means. FIG. 14B shows clusters connected wirelessly. FIG. 14C shows a wireless cluster with transponders and with a network wired connection to the Internet. FIG. 14D shows a network client/server wired system with transponders.

FIG. 15 is a simplified diagram of a section of a computer network, such as the Internet, showing an embodiment of a

routing means whereby a PC request for shared processing is routed within a network using broad bandwidth connection means to another area in a network with one or more idle PC's available.

FIGS. 16A-16Z, 16AA, and 16AB show a new hierarchical network architecture for personal computers and/or microprocessors based on subdivision of parallel processing or multi-tasking operations through a number of levels down to a processing level.

FIGS. 17A-17D show an internal firewall 50 with a dual function, including that of protecting Internet users (and/or other network users sharing use) of one or more slave personal computers PC 1 or microprocessors 40 from unauthorized surveillance or intervention by an owner/operator of those slave processors.

FIGS. 18A-18D show designs for one or more virtual quantum computers integrated into one or more digital computers.

FIG. 19 shows special adaptations to allow the use of idle automobile computers to be powered and connected to the Internet (or other net) for parallel or multi-tasking processing.

FIGS. 20A and 20B show separate broad bandwidth outputs or inputs such as an optical connection like glass fiber from each microprocessor 40 or 94.

FIGS. 21A and 21B are similar to FIGS. 20A and 20B, but show additionally that all microprocessors of a personal computer or personal computer on a microchip can have a separate input/output communication link to a digital signal processor (DSP) or other transmission/reception connection component. FIG. 21C shows a H-tree configuration of binary tree networks.

FIG. 22A shows a PC microprocessor on a microchip similar to that of FIG. 21B, except that FIG. 22A shows microprocessors 93 and 94 each connecting to an optical wired connection 99' such as thin mirrored hollow wire or optical omniguide or optical fiber.

FIGS. 23A-23E show multiple firewalls 50 within a personal computer 1 or PC microchip 90.

FIG. 24 shows a hard drive with an internal firewall 50.

FIGS. 25A-25D show the use for security of power interruption or data overwrite of volatile memory like DRAM and non-volatile memory like Flash or MRAM (or ovonics), respectively, of the network portion of a personal computer PC1 or system on a microchip PC90.

FIGS. 26A-26C show exemplary microchip and photovoltaic cell embodiments.

FIGS. 27A-27H show exemplary microchip and Faraday Cage embodiments.

FIG. 28 shows a silicon wafer 500 used to make microchips.

FIG. 29A shows a top view of a microchip 501 surrounded by adjoining portions of adjoining microchips 501 in a section of the silicon wafer 500. FIG. 29B shows a top view of the microchip 501 embodiment of FIG. 29A after the die has been separated from the silicon wafer 500 and positioned in a microchip package 503.

FIGS. 30A-30C show alternative embodiments that unite separate fabrication processes on the same, microchip 501.

FIG. 31 shows a combination of the embodiments shown in FIGS. 29 and 30.

DETAILED DESCRIPTION OF THE PREFERRED EMBODIMENTS

Embodiments useful for a network of computers are presented. In an embodiment, an apparatus includes a microchip and a Faraday Cage. The microchip includes a personal com-

puter with a general purpose microprocessor on the microchip. The Faraday Cage surrounds at least a portion of the microchip. In another embodiment, an apparatus includes a microchip. The microchip includes a general purpose microprocessor and one or more photovoltaic cells.

The new network computer utilizes PC's as providers of computing power to the network, not just users of network services. These connections between network and personal computer are enabled by a new form of computer/network financial structure that is rooted in the fact that economic resources being provided the network by PC Owners (or leaser) are similar in value to those being provided by the network provider providing connectivity.

Unlike existing one-way functional relationships between PC users and network providers such as internet service providers, which often currently utilize telecommunications networks for connectivity, wherein the network provider provides access to a network like the Internet for a fee, much like cable TV services, this new relationship recognizes that the PC user is also providing the network access to the user's PC for parallel computing use, which has a similar value. The PC thus both provides and uses services on the network, alternatively or potentially even virtually simultaneously, in a multitasking mode.

This new network operates with a structural relationship that is roughly like that which presently exists between an electrical power utility and a small independent power generator connected to a deregulated utility's electrical power grid, wherein electrical power can flow in either direction between utility and independent generator depending on the operating decisions of both parties, and at any particular point in time each party is in either a debt or credit position relative to the other based on the net direction of that flow for a given period, and each party is billed accordingly. In the increasingly deregulated electrical power industry, electrical power, in terms of creation and transmission, is becoming a commodity bought and sold in a competitive marketplace that crosses traditional borders. With the structural relationship proposed herein for the new network, parallel free market structures can develop over time in a new computer power industry dominated by networks of personal computers in all their forms providing shared processing in a grid scaling almost seamlessly from local to national to international like an open market electrical power grid.

For this new network and its structural relationships, a network provider or Internet service provider (ISP) is defined in the broadest possible way as any entity (corporation or other business, government, not-for-profit, cooperative, consortium, committee, association, community, or other organization or individual) that provides personal computer users (very broadly defined below) with initial and continuing connection hardware and/or software and/or firmware and/or other components and/or services to any network, such as the Internet and WWW or Internet II or Next Generation Internet (NGI) or their present or future equivalents, coexistors, or successors, like the herein proposed Grid (or MetaInternet), including any of the current or future types of Internet access providers (ISP's) including telecommunication companies, television cable or broadcast companies, electrical power utilities or other related companies, satellite communications companies, or their present or future equivalents, coexistors or successors.

The connection means used in the networks of the network providers, including between personal computers or equivalents or successors, may be very broad bandwidth, including electromagnetic connections and optical connections, including wired like fiber optic cable or wireless like optical wire-

less, for example, but not excluding any other electromagnetic or other means, including television coaxial cable and telephone twisted pair, as well as associated gateways, bridges, routers, and switches with all associated hardware and/or software and/or firmware and/or other components and their present or future equivalents or successors. The computers used by the Internet service providers include any current or future computers, including such current examples as mainframes, minicomputers, servers, and personal computers, and their associated hardware and/or software and/or firmware and/or other components, and their present or future equivalents or successors.

Other levels of network control beyond the Internet or other network service provider also exist to control any aspect of the parallel processing network structure and function, any one of which levels may or may not control and interact directly with the PC user. For example, at least one level of network control like the World Wide Web Consortium (W3C) or Internet Society (ISOC) or other ad hoc industry, consortia establish and ensure compliance with any prescribed parallel processing network standards and/or protocols and/or industry standard agreements for any hardware and/or software and/or firmware and/or other component connected to the network. Under the consensus control of these consortia/societies, other levels of the parallel, processing network control can deal with administration and operation of the network. These other levels of the parallel processing network control can potentially be constituted by any network entity, including those defined immediately above for network providers.

The principal defining characteristic of the parallel processing network herein described is communication connections (including hardware and/or software and/or firmware and/or other component) of any form, including electromagnetic (such as radio or microwaves and including light) and electrochemical; (and not excluding biochemical or biological), between PC users and their computers, with connection (either directly or indirectly) to the largest number possible of users and their computers and microprocessors being highly advantageous, such as networks like the Internet (and Internet II and the Next Generation Internet) and WWW and equivalents and successors, like the Grid (or MetaInternet). Multiple levels of such networks will likely coexist with different technical capabilities, like Internet and Internet II, but have interconnection and therefore communicate freely between levels, for such standard network functions as electronic mail, for example.

A personal computer (PC) user is defined in the broadest possible way as any individual or other entity routinely using a personal computer, which is defined as any computer, such as digital or analog or neural or quantum, particularly including personal use microprocessor-based personal computers having one or more general purpose microprocessors (each including one or more parallel processors) in their general current form, including hardware with fixed or reconfigurable circuitry (such as field-programmable gate array or FPGA) and/or electro-mechanical components (including micro or nano sized) and/or optical components, including all-optical, and/or software and/or firmware and/or any other component and their present and future equivalents or successors, such as application-specific (or several application) computers, network computers, handheld personal digital assistants, personal communicators such as telephones and pagers, wearable computers, digital signal processors, neural-based computers (including PC's), entertainment devices such as televisions and associated cable digital set-top control boxes, video tape recorders, video electronic games, videocams,

compact or digital video disk (CD or DVD) player/recorders, radios and cameras, other household electronic devices, business electronic devices such as printers, copiers, fax machines, footwear, automobile or other transportation equipment devices, robots, toys, and other electronic devices, especially including those owned (or leased directly or indirectly) and used directly by individuals, utilizing one or more microprocessors, including those made of inorganic compounds such as silicon and/or other inorganic or organic (including biological, such as DNA) compounds, and other current or successor devices incorporating one or more microprocessors (or functional or structural equivalents), including routers, switches, and other network devices, as well as current and future forms of mainframe computers, minicomputers, workstations, and even supercomputers, as well as routers, switches, and other electrical or optical network devices (or microelectro-mechanical devices such as MEMS), that can be considered as PCs in the distributed processing network described herein, since they can be used functionally in the same general way in the network as a PC or a PC can be used to perform their functions, at least in a limited fashion alone or more effectively in numbers that are aggregated together or distributed. Such personal computers as defined above have owners or leasers, which may or may not be the same as the computer users. Continuous connection of computers to the network, such as the Internet, WWW, or equivalents or successors, is not required, since connection can also be made at the initiation of a shared processing operation.

Parallel processing is defined as one form of shared processing involving two or more microprocessors used in solving the same computational problem or other task. Massively parallel microprocessor processing involves large numbers of microprocessors. In today's technology, massive parallel processing is probably to be considered to be about 64 microprocessors (referred to in this context as nodes) and over 7,000 nodes have been successfully tested in an Intel supercomputer design using PC microprocessors (Pentium Pros). It is anticipated that continued software improvements will make possible effective use of a much larger number of very possibly limited only by the number of microprocessors available for use on a given network, even an extraordinarily large one like the Internet or its equivalents and/or successors, like the Grid (or MetaInternet). Shared processing also includes multitasking, which is unrelated processing in parallel.

Broadband wavelength or broad bandwidth network transmission is defined here to mean a transmission speed (usually measured in bits per second) that is at least high enough (or roughly at least equivalent to the internal clock speed of the microprocessor or microprocessors times the number of microprocessor channels equaling instructions per second or operations per second or calculations per second) so that the processing input and output of the microprocessor is substantially unrestricted, particularly including at peak processing levels, by the bandwidth of the network connections between microprocessors that are performing some form of parallel processing, particularly including massive parallel processing. Since this definition is dependent on microprocessor speed, it increases as microprocessor speeds increase. For microchips with more than one processor, the network connection to the microchip may have bandwidth broad enough to ensure that all of the microprocessors are unrestricted by a bottleneck at the connection during the microprocessors' peak processing levels.

However, a connection means referenced above is a light wave or optical waveguide connection such as fiber optic

cable, which in 1996 already provided multiple gigabit bandwidth on single fiber thread and is rapidly improving significantly on a continuing basis, so the general use of optical waveguide connections such as fiber between PCs may assure broad bandwidth for data transmission that is far greater than microprocessor and associated internal bus speed to provide data to be transmitted. In addition, new wired optical connections or waveguide in the form of thin, mirrored hollow wires or tubes called omniguides offer even much greater bandwidth than optical fiber and without need for amplification when transmitting over distances, unlike optical fiber. The connection means to provide broad bandwidth transmission is either wired or wireless, with wireless (especially optical) generally provided for mobile personal computers (or equivalents or successors) and as otherwise indicated below. Wireless connection bandwidth is also increasing rapidly and optical wireless bandwidth is considered to offer essentially the same benefit as fiber optic cable: data transmission speed that exceeds data processing speed.

The financial basis of the shared use between owners/lessees and providers is whatever terms to which the parties agree, subject to governing laws, regulations, or rules, including payment from either party to the other based on periodic measurement of net use or provision of processing power, in a manner like an deregulated or open market electrical power grid.

In one embodiment, as shown in, FIG. 1, in order for this network structure to function effectively, there is a meter device **5** (comprising hardware and/or software and/or firmware and/or other component) to measure the flow of computing power between PC **1** user and network **2** provider, which may provide connection to the Internet and/or World Wide Web and/or Internet II and/or any present or future equivalent or successor **3**, like the Grid (or MetaInternet). In one embodiment, the PC user may be measured by some net rating of the processing power being made available to the network, such as net score on one or more standard tests measuring speed or other performance characteristics of the overall system speed, such as PC Magazine's benchmark test program, ZD Winstone (potentially including hardware and/or software and/or firmware and/or other component testing) or specific individual scores for particularly important components like the microprocessor (such as MIPS or millions of instructions per second) that may be of application-specific importance, and by the elapsed time such resources were used by the network. In the simplest case, for example, such a meter need measure only the time the PC was made available to the network for processing **4**, which can be used to compare with time the PC used the network (which is already normally measured by the provider, as discussed below) to arrive at a net cost; potential locations of such a meter include at a network computer such as a server, at the PC, and at some point on the connection between the two. Throughput of data in any standard terms is another potential measure.

In another embodiment, as shown in FIG. 2, there also is a meter device **7** (comprised of hardware and/or software and/or firmware and/or other component) that measures the amount of network resources **6** that are being used by each individual PC **1** user and their associated cost. This includes, for example, time spent doing conventional downloading of data from sites in the network or broadcast from the network **6**. Such metering devices currently exist to support billing by the hour of service or type of service, as is common in the public industry, by providers such as America Online, CompuServe, and Prodigy. The capability of such existing devices is enhanced to include a measure of parallel processing resources that are allocated by the Internet Service Provider

or equivalent to an individual PC user from other PC users **6**, also measured simply in time. The net difference in time **4** between the results of meter **5** and meter **7** for a given period provides a reasonable billing basis.

Alternately, as shown in FIG. 3, a meter **10** also estimates to the individual PC user prospectively the amount of network resources needed to fulfill a processing request from the PC user to the network (provider or other level of network control) and associated projected cost, provides a means of approving the estimate by executing the request, and a real-time readout of the cost as it occurs (alternatively, this meter may be done only to alert **9** the PC user that a given processing request **8** falls outside normal, previously accepted parameters, such as level of cost). For an unusually deep search request, a priority or time limit and depth of search may be criteria or limiting parameters that the user can determine or set with the device, or that can be preset, for example, by the network operating system of the ISP or by the operating system of the PC or other components of the parallel processing system.

The network may involve no payment between users and providers, with the network system (software, hardware, etc.) providing an essentially equivalent usage of computing resources by both users and providers (since any network computer operated by either entity can potentially be both a user and provider of computing resources (even simultaneously, assuming multitasking), with potentially an override option by a user (exercised on the basis, for example, of user profile or user's credit line or through relatively instant payment).

As shown in FIGS. 4A-4C, the priority and extent of use of PC and other users may be controlled on a default-to-standard-of-class-usage basis by the network (provider or other) and overridden by the user decision on a basis prescribed by the specific network provider (or by another level of network control). One example of a default basis is to expend up to a PC's or other user's total, credit balance with the provider described above and the network provider then to provide further prescribed service on a debt basis up to some set limit for the user; different users may have different limits based on resources and/or credit history.

A specific category of PC user based, for example, on specific microprocessor hardware owned or leased, may have access to a set maximum number of parallel PC's or microprocessors, with smaller or basic users generally having less access and vice versa. Specific categories of users may also have different priorities for the execution of their processing by the network other than the simplest case of first come, first served (until complete). A very wide range of specific structural forms between user and provider are possible, both conventional and new, based on unique features of the new network computer system of shared processing resources.

For example, in the simplest case, in an initial system embodiment, as shown in FIG. 4A, a standard PC **1** user request **11** for a use involving parallel processing may be defaulted by system software **13**, as shown in FIG. 4B, to the use of only one other essentially identical PC **1₂** microprocessor for parallel processing or multitasking, as shown in FIG. 4C; larger standard numbers of PC microprocessors, such as about three PC's at the next level, as shown in later FIG. 10G (which could also illustrate a PC **1** user exercising an override option to use a level of services above the default standard of one PC microprocessor, presumably at extra cost), for a total of about four, then about 8, about 16, about 32, about 64, and so on, or virtually any number in between, is made available as the network system is upgraded in simple phases over time, as well as the addition of sophisti-

cated override options. As the phase-in process continues, many more PC microprocessors can be made available to the standard PC user (virtually any number), starting at about 128, for example, then about 256, then about 512, then about 1024 and so on over time, as the network and all of its components are gradually upgraded to handle the increasing numbers. System scalability, at even the standard user level is essentially unlimited over time.

For most standard PC users (including present and future equivalents and successors), connection to the Internet or present or future equivalents or successors like the Grid (or MetaInternet) may be at no cost to PC users, since in exchange for such Internet access the PC users can generally make their PC, when idle, available to the network for shared processing. Competition between Internet Service Providers (including present and future equivalents and successors) for PC user customers may be over such factors as the convenience and quality of the access service provided and of shared processing provided at no additional cost to standard PC users, or on such factors as the level of shared processing in terms, for example, of number of slave PC's assigned on a standard basis to a master PC. The ISP's can also compete for parallel processing operations, from inside or outside the ISP Networks, to conduct over their networks.

In addition, as shown in FIGS. 5A-5B, in another embodiment there is a (hardware and/or software and/or firmware and/or other) controlling device to control access to the user's PC by the network. In its simplest form, such as a manually activated electromechanical switch, the PC user could set this controller device to make the PC available to the network when not in use by the PC user. Alternatively, the PC user could set the controller device to make the PC available to the network whenever in an idle state, however momentary, by making use of multitasking hardware and/or software and/or firmware and/or other component (broadcast or "push" applications from the Internet or other network could still run in the desktop background).

Or, more simply, as shown in FIG. 5A, whenever the state that all user applications are closed and the PC 1 is available to the network 14 (perhaps after a time delay set by the user, like that conventionally used on screensaver software) is, detected by a software controller device 12 installed in the PC, the device 12 signals 15 the network computer such as a server 2 that the PC available to the network, which could then control the PC 1 for parallel processing or multitasking by another PC. Such shared processing can continue until the device 12 detects an application being opened 16 in the first PC (or at first use of keyboard, for quicker response, in a multitasking environment), when the device 12 signals 17 the network computer such as a server 2 that the PC is no longer available to the network, as shown in FIG. 5B, so the network can then terminate its use of the first PC.

In the embodiment shown in FIG. 6, there is a (hardware and/or software and/or firmware and/or other component) signaling device 18 for the PC 1 to indicate or signal 15 to the network the user PC's availability 14 for network use (and whether full use or multitasking only) as well as its specific (hardware/software/firmware/other components) configuration 20 (from a status 19 provided by the PC) in sufficient detail for the network or network computer such as a server 2 to utilize its capability effectively. In one embodiment, the transponder device is resident in the user PC and broadcasts its idle state or other status (upon change or periodically, for example) or responds to a query signal from a network device.

Also, in another embodiment; as shown in FIG. 7, there is a (hardware/software and/or firmware and/or other component) transponder device 21 resident in a part of the network

(such as network computer, switch, router, or another PC, for example) that receives 22 the PC device status broadcast and/or queries 26 the PC for its status, as shown in FIG. 7.

In one embodiment, as shown in FIG. 8, the network grid also has resident in a part of its hardware and/or software (and/or firmware and/or other components) a capacity such as to allow it to most effectively select and utilize the available user PC's to perform parallel processing initiated by PC users or the network providers or others. To do so, the network grid should have the (hardware and/or software and/or firmware and/or other component) capability of locating each PC accurately at the PC's position on the geographic grid lines/connection means 23 so that parallel processing occurs between PC's (PC 1 and PC 1₂) as close together as possible, which should not be difficult for PC's at fixed sites with a geographic location, customarily grouped together into cells 24, as shown in FIG. 8, but which requires an active system for any wireless microprocessor to measure its distance from its network relay site, as discussed below in FIG. 14.

One of the primary capabilities of the Internet (or Internet II or successor, like the Grid or MetaInternet) or WWW network computer is to facilitate searches by the PC user or other user. As shown in FIG. 9, searches are particularly suitable to multiple processing, since, for example, a typical search is to find a specific Internet or WWW site with specific information. Such site searches can be broken up geographically, with a different PC processor 1' allocated by the network communicating through a wired means 99 as shown (or wireless connections) to search each area, the overall area being divided into eight separate parts, as shown, which may be about equal, so that the total search would be about 1/8 as long as if one processor did it alone (assuming the PC 1 microprocessor provides control only and not parallel processing).

As a typical example, a single PC user might need 1,000 minutes of search time to find what is requested, whereas the network computer, using multiple PC processors, might be able to complete the search in 100 minutes using 10 processors, or 10 minutes using 100 processors or 1 minute using 1,000 processors (or even 1 second using 60,000 processors), assuming performance transparency, which should be achievable, at least over time, even for massive numbers of parallel processors. The parallel processing network's external parallel processing may be completely scalable, with virtually no theoretical limit.

The above examples also illustrates a tremendous potential benefit of network parallel processing. The same amount of network, resources, 60,000 processor seconds, was expended in each of the equivalent examples. But by using relatively large multiples of processors, the network can provide the user with relatively immediate response with no difference in cost (or relatively little difference)—a major benefit. In effect, each PC user linked to the network providing external parallel processing becomes, in effect, a virtual supercomputer. As discussed below, supercomputers can experience a similar spectacular leap in performance by employing a thousand-fold (or more) increase in microprocessors above current levels.

Such power will likely be required for any effective searches in the World Wide Web (WWW). WWW is currently growing at a rate such that it is doubling every year, so that searching for information within the WWW will become geometrically more difficult in future years, particularly a decade hence, and, it is already a very significant difficulty to find WWW sites of relevance to any given search and then to review and analyze the contents of the site.

In addition, many more large databases are being made Web accessible and the use of Extensible Markup Language (XML) will accelerate that trend. Moreover, existing search engine results list information from a prior general search and merely summarized on the web servers of search engine operators, whereas embodiments of the present invention allow a further contemporaneous specifically targeted search directed by the PC user utilizing search engine results only as a starting point for much greater depth and analysis allowed by the shared use of many other PC's in a parallel processing operation.

Therefore, the capability to search with massive parallel processing can dramatically enhance the capabilities of scientific, technological and medical researchers.

Such enhanced capabilities for searching (and analysis) can also fundamentally alter the relationship of buyers and sellers of any items and/or services. For the buyer, massive parallel network processing can make it possible to find the best price, worldwide, for any product or the most highly rated product or service (for performance, reliability, etc.) within a category or the best combination of price/performance or the highest rated product for a given price point and so on. The best price for the product can include best price for shipping within specific delivery time parameters acceptable to the buyer.

For the seller, such parallel processing can drastically enhance the search, worldwide, for customers potentially interested in a given product or service, providing very specific targets for advertisement. Sellers and producers can know their customers directly and interact with them directly for feedback on specific products and services to better assess customer satisfaction and survey for new product development.

Similarly, the vastly increased capability provided by the system's shared parallel processing can produce major improvements in complex simulations like modeling worldwide and local weather systems over time, as well as design and testing of any structure or product, from airliners and skyscrapers to new drugs and to the use of much more sophisticated artificial intelligence (AI) in medical treatment and in sorting through and organizing the PC users' voluminous input of electronic data from "push" technologies. Improvements in games also result, especially in terms of realistic simulation and realtime interactivity.

The Internet or WWW network computer system like the Grid (or MetaInternet) can put into the hands of the PC user an extraordinary new level of computer power vastly greater than the most powerful supercomputer existing today. The world's total of microchips was already about 350 billion in 1997, of which about 15 billion are microprocessors of some kind; most are fairly simple "appliance" type microchips running wrist watches, televisions, cameras, cars, telephones, etc. Assuming growth at its current rates, in a decade the Internet/Internet II/WWW may have a billion individual PC users, each providing an average total of at least 10 highly sophisticated microprocessors (assuming PC's with at least 4 microprocessors (or more, such as 16 microprocessors or 32, for example) and associated other handheld, home entertainment, and business devices with microprocessors or digital processing capability, like a digital signal processor or successor devices. That results in a global computer a decade from now made of at least 10 billion microprocessors, interconnected by broad bandwidth electromagnetic wave means at speeds approaching the speed of light.

In addition, the exceptionally numerous special purpose "appliance" microprocessors noted above, especially those that operate now intermittently like personal computers, may

be designed to the same basic consensus industry standard used for parallel microprocessors for PC's (or equivalents or successors) or for PC "systems on a chip", discussed later in FIGS. 10A-H, so that all PCs and microprocessors function homogeneously or are homogeneous in the parallel processing Internet. If such PCs and, appliance microprocessors are also connected by any broad bandwidth means including fiber optic cable or optical wireless or other wireless, then the number of parallel processors potentially available can increase roughly about 10 times, for a net potential "standard" computing performance of up to 10,000 times current performance within, fifteen years, exclusive of Moore's Law routine increases. Web-based ubiquitous computing would become a reality, in terms either of direct connection to the Web or use of common Web standards.

Moreover, in an environment where all current intermittently operating microprocessors follow the same basic design standards so that all are homogeneous parallel processors, then although the cost per microprocessor increases somewhat, especially initially, the net cost of computing for all users falls drastically due to the general performance increase due to the use of billions of otherwise idle "appliance" microprocessors. Therefore, the overall system cost reduction compels a transformation of virtually all such microprocessors, which are currently specialty devices known as application-specific integrated circuits (ASICs), into general microprocessors (like PC's), with software and firmware providing most of their distinguishing functionality. As noted above, homogeneity of parallel (and multi-tasking) processing design standards for microprocessors and network, including local and Internet, may be employed, but heterogeneity is also a well established parallel processing alternative providing significant benefits compared to non-parallel processing.

A typical supercomputer today utilizing the latest PC microprocessors has less than a hundred. Using network linkage to all external parallel processing, a peak maximum of perhaps 1 billion microprocessors can be made available for a network supercomputer user, providing it with the power 10,000,000 times greater than is available using current conventional internal parallel processing supercomputers (assuming the same microprocessor technology). Because of its virtually limitless scalability mentioned above, resources made available by the network to the supercomputer user or PC user can be capable of varying significantly during any computing function, so that peak computing loads can be met with effectively whatever level of resources are necessary.

In summary, regarding monitoring the net provision of power between PC and network, FIGS. 1-9 show embodiments of a system for a network of computers, including personal computers, comprising: means for network services including browsing functions, as well as shared computer processing such as parallel processing, to be provided to the personal computers within the network; at least two personal computers; means for at least one of the personal computers, when idled by a personal user, to be made available temporarily to provide the shared computer processing services to the network; and means for monitoring on a net basis the provision of the services to each personal computer or to the personal computer user. In addition, FIGS. 1-9 show embodiments including where the system is scalar in that the system imposes no limit to the number of the personal computers, including, at least 1024 personal computers; the system is scalar in that the system imposes no limit to the number of personal computers participating in a single shared computer processing operation, including at least 256 personal computers; the network is connected to the Internet and its equivalent

lents and successors, so that the personal computers include at least a million personal computers; the network is connected to the World Wide Web and its successors; the network includes at least one network server that participates in the shared computer processing; the monitoring means includes a meter device to measure the flow of computing power between the personal computers and the network; the monitoring means includes a means by which the personal user of the personal computer is provided with a prospective estimate of cost for the network to execute an operation requested by the personal user prior to execution of the operation by the network; the system has a control means by which to permit and to deny access to the personal computers by the network for shared computer processing; access to the personal computers by the network is limited to those times when the personal computers are idle; and the personal computers having at least one microprocessor and communicating with the network through a connection means having a speed of data transmission that is at least greater than a peak data processing speed of the microprocessor.

Also, relative to maintaining a standard cost, FIGS. 1-9 show embodiments of a system for a network of computers, including personal computers, comprising: means for network services including browsing functions, as well as shared computer processing such as parallel processing, to be provided to the personal computers within the network; at least two personal computers; means for at least one of the personal computers, when idled by a personal user, to be made available temporarily to provide the shared computer processing services to the network; and means for maintaining a standard cost basis for the provision of the services to each personal computer or to the personal computer user. In addition, FIGS. 1-9 show embodiments including where the system is scalar in that the system imposes no limit to the number of personal computers, including at least 1,024 personal computers; the system, is scalar in that the system imposes no limit to the number of the personal computers participating in a single shared computer processing operation, including at least 256 personal computers; the network is connected to the Internet and its equivalents and successors, so that the personal computers include at least a million personal computers; the standard cost is fixed; the fixed standard cost is zero; the means for maintaining a standard cost basis includes the use of making available a standard number of personal computers for shared processing by personal computers; the network is connected to the World Wide Web and its successors; the personal user can override the means for maintaining a standard cost basis so that the personal user can obtain additional network services; the system has a control means by which to permit and to deny access to the personal computers by the network for shared computer processing; the personal computers having at least one microprocessor and communicating with the network through a connection means having a speed of data transmission that is at least greater than a peak data processing speed of the microprocessor.

Browsing functions generally include functions like those standard functions provided by current Internet browsers, such as Microsoft Explorer 3.0 or 4.0 and Netscape Navigator 3.0 or 4.0, including at least access to searching World Wide Web or Internet sites, exchanging E-Mail worldwide, and worldwide conferencing; an intranet network uses the same browser software, but may not include access to the Internet or WWW. Shared processing includes parallel processing and multitasking processing involving more than two personal computers, as defined above. The network system is entirely scalar, with any number of PC microprocessors potentially possible.

As shown in FIGS. 10A-10F, to deal with operational and security issues, it may be beneficial for individual users to have one microprocessor or equivalent device that is designated, permanently or temporarily, to be a master 30 controlling device (comprising hardware and/or software and/or firmware and/or other component) that remains inaccessible (using, for example, a hardware and/or software and/or firmware and/or other component firewall 50) directly by the network but which controls the functions of the other slave microprocessors 40 when the network is not utilizing them.

For example, as shown in FIG. 10A, a typical PC 1 may have four or five microprocessors (even on, a single microprocessor chip), with one master 30 and three or four slaves 40, depending on whether the master 30 is a controller exclusively (through different design of any component part), requiring four slave microprocessors 40; or the master microprocessor 30 has the same or equivalent microprocessing capability as a slave 40 and multiprocesses in parallel with the slave microprocessors 40, thereby requiring only three slave microprocessors 40. The number of PC slave microprocessors 40 can be increased to virtually any other number, such as at least about eight, about 16, about 32, about 64, about 128, about 256, about 512, about 1024, and so on. These multiples are not required, and the number of PC master microprocessors 30 may be increased. Also included is an internal firewall 50 between master 30 and slave 40 microprocessors. As shown in preceding FIGS. 1-9, the PC 1 in FIG. 10A may be connected to a network computer 2 and to the Internet or WWW or present or future equivalent or successor 3, like the Grid (or MetaInternet).

Other typical PC hardware components such as hard drive 61, floppy diskette drive 62, compact disk-read only memory (CD-ROM) 63, digital video disk (DVD) 64, Flash memory 65, random access memory (RAM) 66, video or other display 67, graphics card 68, and sound card 69, as well as digital signal processor or processors, together with the software and/or firmware stored on or for them, can be located on either side of internal firewall 50, but such devices as the display 67, graphics card 68 and sound card 69 and those devices that both read and write and have non-volatile memory (retain data without power and generally have to be written over to erase), such as hard drive 61, Flash memory 65, floppy diskette drive 62, read/write CD-ROM 63 or DVD 64 may be located on the PC user side of the internal firewall 50, where the master microprocessor is also located, as shown in FIG. 10A, for security reasons; their location can be flexible, with that capability controlled such as by password-authorized access.

Alternately, any of these devices that are duplicative (or for other exceptional needs) like a second hard drive 61', can be located on the network side of the internal firewall 50. RAM 66 or equivalent or successor memory, which typically is volatile (data is lost when power is interrupted), should generally be located on the network side of the internal firewall 50, but some can be located with the master microprocessor to facilitate its independent use.

However, read-only memory (ROM) devices including most current CD drives (CD-ROM's) 63' or DVD's (DVD-ROM) drives 64' can be safely located on the network side of the internal firewall 50, since the data on those drives cannot be altered by network users; preemptive control of use may remain with the PC user.

However, at least a portion of RAM can be kept on the Master 30 microprocessor side of the internal firewall 50, so that the PC user can retain the ability to use a core of user PC 1 processing capability entirely separate from any network processing. If this capability is not desired, then the master 30

microprocessor can be moved to the network side of the internal firewall 50 and replaced with a simpler controller on the PC 1 user side, like the master remote controller 31 discussed below and shown in FIG. 10I.

The master microprocessor 30 may also control the use of several or all other processors 60 owned or leased by the PC user, such as home entertainment digital signal processors 70, especially if the design standards of such microprocessors in the future conform to the requirements of network parallel processing as described above. In this general approach, the PC master processor uses the slave microprocessors or, if idle (or working on low priority, deferrable processing), makes them available to the network provider or others to use. Wireless connections 100, including optical wireless, are expected to be extensively used in home or business network systems, including use of a master remote controller 31 without (or with) microprocessing capability, with broad bandwidth connections such as fiber optic cable connecting directly to at least one component such as a PC 1, shown in a slave configuration, of the home or business personal network system; that connection links the home system to the network 2 such as the Internet 3, as shown in FIG. 10I. A business system may include broadband such as fiber optic or optical wireless links to most or all personal computers PC 1 and other devices with microprocessors, such as printers, copiers, scanners, fax machines, telephone and video conferencing equipment; other wired or wireless links also can be used.

A PC 1 user can remotely access his networked PC 1 by using another networked master microprocessor 30 on another PC 1 and using a password or other access control means for entry to his own PC 1 master microprocessor 30 and files, as is common now in Internet and other access. Alternately, a remote user can simply carry his own digitally stored files and his own master microprocessor or use another networked master microprocessor temporarily has his own.

In the simplest configuration, as shown in FIG. 10B, the PC 1 may have a single master microprocessor 30 and a single slave microprocessor 40, separated by an internal firewall 50, with both processors used in, parallel or multitasking processing or with only the slave 40 so used, and connected with broad bandwidth such as optical fiber wire 99 to a network computer 2 and Internet 3 and successors like the Grid (or MetaInternet). Virtually any number of slave microprocessors 40 is possible. The other non-microprocessor components shown in FIG. 10A above may also be included in this simple FIG. 10B configuration.

As shown in FIG. 10C, microchips 90 are expected to integrate most or all of the other necessary computer components (or their present or future equivalents or successors), like a PC's volatile memory like RAM 66 (such as DRAM), graphics 82, sound 83, power management 84, network communications 85, and video processing 86, possibly including modem 87, non-volatile memory like flash (or magnetic like MRAM or ovonic unified memory) 88, system BIOS 88', digital signal processor (DSP) or processors 89, and other components or present or future equivalents or successors) and internal-bus, on a single chip 90 (silicon, plastic, or other), known in the industry as "system on a chip". Such a PC microchip 90 can have the same architecture as that of the PC 1 shown above in FIG. 10A: namely, a master control and/or processing unit 93 and one or more slave processing units 94 (for parallel or multitasking processing by either the PC 1 or the Network 2), separated by an internal firewall 50 and connected by broad bandwidth wire 99 such as optical fiber cable to a network computer 3 and the Internet 3 and successors like the Grid (or MetaInternet). Alternatively, microchip 90 can be an "appliance" system on a chip.

Existing PC components with mechanical components like hard drive 61, floppy or other removable diskette 62, CD-ROM 63, and DVD 64, which are mass storage devices with mechanical features that will likely not become an integral part of a PC "system of a chip" may still be capable of connection to a single PC microchip 90 and control by a single PC master unit 93.

In the simplest multi-processor case, as shown in FIG. 10D, the chip 90 has a single master unit 93 and at least one slave unit 94 (with the master having a controlling function only or a processing function also), separated by an internal firewall 50 and connected by broad bandwidth wire 99 such as fiber optic cable to a network computer 3 and the Internet 3 (and successors like the Grid or MetaInternet). The other non-microprocessor components shown in FIG. 10A above may also be included in this simple FIG. 10D configuration.

As noted above, any computer may be both a user and provider, alternatively—a dual mode operating capability. Consequently, any PC 1 within the network 2, connected to the Internet 3 and successors like the Grid (or MetaInternet), can be temporarily a master PC 30 at one time initiating a parallel or multitasking processing request to the network 2 for execution by at least one slave PC 40, as shown in FIG. 10E. At another time the same PC 1 can become a slave PC 40 that executes a parallel or multitasking processing request by another PC 1' that has temporarily assumed the function of master 30, as shown in FIG. 10F. The simplest approach to achieving this alternation is for both master and slave versions of the parallel processing software to be loaded in each or every PC 1 that is to share in the parallel processing, so each PC 1 has the necessary software means, together with minor operational modifications, such as adding a switching means by which a signaled request for parallel processing initiated by one PC 1 user using master software is transmitted to at least a second PC 1, triggering its slave software to respond by initiating parallel processing.

As shown in FIGS. 10G and 10H, which are parallel to FIGS. 10E and 10F, the number of PC slave processors 40 can be increased to any virtually other number, such as at least about 4; as shown, the processing system is completely scalar, so that further increases can occur to, for example, about eight, about 16, about 32, about 64, about 128, about 256, about 512, about 1024, and so on; the PC master microprocessors 30 can also be increased.

In summary, as noted above relative to FIG. 10I, a PC 1 can function as a slave PC 40 and be controlled by a master controller 31, which can be remote and which can have limited or no microprocessing capability, but can as well have similar or greater capability. As shown in FIGS. 10J and 10K, such a master controller 31 is located on the PC user side of the internal firewall 50, under the control of the PC user, while the microprocessors 40 reside on the network side of the internal firewall 50. The master controller 31 may receive input from the PC user by local means such as keyboard, microphone, videocam or future hardware and/or software and/or firmware or other equivalent or successor interface means (as does a master processor 40) that provides input to a PC 1 or microprocessor 30 originating from a user's hand, voice, eye, nerve or nerves, or other body part; in addition, remote access by telephone, cable, wireless or other connection may also be enabled by a hardware and/or software and/or firmware and/or other means with suitable security such as password controlled access. Similarly, as shown in FIGS. 10L and 10M, relative to a PC "system on a chip", a master controller unit 93' (which could be capable of being accessed by the PC user through a remote controller 31) with only a controlling capability can be located on the PC user

side of the internal firewall **50**, under the control of the PC user, while the slave processor units **94** would reside on the network side of the internal firewall **50**.

FIGS. **10N** and **10O** show PC **1** with an internal firewall **50** that is configurable through either hardware and/or software and/or firmware and/or other means; software configuration is easiest and most typical, but active motherboard hardware configuration is possible and may present some security advantages, including a use of manual or electromechanical or other switches or locks. FIG. **10N** shows a CD-ROM **63'** that has been placed by a PC user on the network side of an internal firewall **50**, from a previous position on the PC user side of an internal firewall **50**, which was shown in FIG. **10A**. The settings of an internal firewall **50** may default to those that safely protect the PC **1** from uncontrolled access by network users, but with capability for the relatively sophisticated PC user to override such default settings and yet with proper safeguards to protect the unsophisticated user from inadvertently doing so; configuration of an internal firewall **50** may also be actively controlled by a network administrator in a local network like that of a business, where a PC user may not be the owner or leaser of the PC being used, either by remote access on the network or with a remote controller **31**.

Similarly, FIGS. **10P** and **10Q** show a PC "system on a chip" **90** with an internal firewall **50** that is configurable through either hardware and/or software and/or firmware and/or other means; software configuration is easiest and most typical. Active configuration of the integrated circuits of the PC microchip **90** is also possible and may present some speed and security advantages. Such direct configuration of the circuits of the microchip **90** to establish or change its internal firewall **50** could be provided by the use of field-programmable gate arrays (or FPGA's) or their future equivalents or successors; microcircuit electromechanical or other switches or locks can also be used potentially. In FIG. **10P**, for example, slave processing unit **94'** has been moved to the PC user side of an internal firewall **50** from a network side position shown in FIGS. **10C** and **10L**. Similarly, FIG. **10Q** shows the same active configuration of chip circuit using FPGA's for the simplest form of multiprocessing microchip **90** with a single slave unit **94'**, transferring its position to the PC user's side of an internal firewall **50** from a network side shown in FIGS. **10M** and **10D**.

In summary, relative to the use of master/slave computers, FIGS. **10A-10I** show embodiments of a system for a network of computers, including personal computers, comprising: at least two personal computers; means for at least one personal computer, when directed by its personal user, to function temporarily as a master personal computer to initiate and control the execution of a computer processing operation shared with at least one other personal computer in the network; means for at least one other personal computer, when idled by its personal user, to be made available to function temporarily as at least one slave personal computer to participate in the execution of a shared computer processing operation controlled by the master personal computer; and means for the personal computers to alternate as directed between functioning as a master and functioning as a slave in the shared computer processing operations. In addition, FIGS. **10A-10H** show embodiments including those wherein the system is scalar in that the system imposes no limit to the number of personal computers; for example, the system can include at least 256 said personal computers; the system is scalar in that the system imposes no limit to the number of personal computers participating in a single shared computer processing operation, including at least 256 said personal computers, for example; the network is connected to the

Internet and its equivalents and successors, so that personal computers include at least a million personal computers, for example; the shared computer processing is parallel processing; the network is connected to the World Wide Web and its successors; a means for network services, including browsing and broadcast functions, as well as shared computer processing such as parallel processing, are provided to said personal computers within said network; the network includes at least one network server that participates in the shared computer processing; the personal computers include a transponder or equivalent or successor means so that a master personal computer can determine the closest available slave personal computers; the closest available slave personal computer is compatible with the master personal computer to execute said shared computer processing operation; the personal computers having at least one microprocessor and communicating with the network through a connection means having a speed of data transmission that is at least greater than a peak data processing speed of the microprocessor; and a local network PC **1** being controlled remotely by a microprocessor controller **31**.

Use of the internal firewall **50**, as described above in FIGS. **10A-10I**, provides a solution to a security problem by completely isolating host PC's **1** that are providing slave microprocessors to the network for parallel or other shared processing functions from any capability to access or retain information about any element about that shared processing. In addition, of course, the internal firewall **50** provides security for the host PC against intrusion by outside hackers; by reducing the need for encryption and authentication, the use of internal firewalls **50** can provide a relative increase in computing speed and efficiency. In addition to computers such as personal computers, the internal firewall **50** described above could be used in any computing device included in this application's above definition of personal computers, including those with "appliance"-type microprocessors, such as telephones, televisions or cars, as discussed above.

In summary, regarding the use of internal firewalls, FIGS. **10A-10I** show embodiments of a system architecture for computers, including personal computers, to function within a network of computers, comprising: a computer with at least two microprocessors and having a connection means with a network of computers; the architecture for the computers including an internal firewall means for personal computers to limit access by the network to only a portion of the hardware, software, firmware, and other components of the personal computers; the internal firewall means will not permit access by the network to at least a one microprocessor having a means to function as a master microprocessor to initiate and control the execution of a computer processing operation shared with at least one other microprocessor having a means to function as a slave microprocessor; and the internal firewall means permitting access by the network to the slave microprocessor. In addition, the system architecture explicitly includes embodiments of, for example, the computer is a personal computer; the personal computer is a microchip; the computer has a control means by which to permit and to deny access to the computer by the network for shared computer processing; the system is scalar in that the system imposes no limit to the number of personal computers, including at least 256 said personal computers, for example; the network is connected to the Internet and its equivalents and successors, so that the personal computers include at least a million personal computers, for example; the system is scalar in that the system imposes no limit to the number of personal computers participating in a single shared computer processing operation, including at least 256 said personal computers, for

25

example; the personal computers having at, least one micro-processor and communicating with the network through a connection means having a speed of data transmission that is at least greater than a peak data processing speed of the microprocessor.

In summary, regarding the use of controllers with internal firewalls, FIGS. 10J-10M show embodiments of a system architecture for computers, including personal computers, to function within a network of computers, comprising for example: a computer with at least a controller and a micro-processor and having a connection means with a network of computers; the architecture for the computers including an internal firewall means for personal computers to limit access by the network to only a portion of the hardware, software, firmware, and other components of the personal computers; the internal firewall means will not permit access by the network to at least a one controller having a means to initiate and control the execution of a computer processing operation shared with at least one microprocessor having a means, to function, as a slave microprocessor; and the internal firewall means permitting access by the network to the slave microprocessor. In addition, the system architecture explicitly includes embodiments of, for example, the computer is a personal computer, the personal computer is a microchip; the computer has a control means by which to permit and to deny access to the computer by the network for shared computer processing; the system is scalar in that the system imposes no limit to the number of personal computers, including at least 256 said personal computers, for example; the network is connected to the Internet and its equivalents and successors, so that the personal computers include at least a million personal computers, for example; the system is scalar in that the system imposes no limit to the number of personal computers participating in a single shared computer processing operation, including at least 256 said personal computers, for example; the personal computers having at least one micro-processor and communicating with the network through a connection means having a speed of data transmission that is at least greater than a peak data processing speed of the microprocessor; and the controller being capable of remote use.

In summary, regarding the use of internal firewalls that can be actively configured, FIGS. 10N-10Q show embodiments of a system architecture for computers, including personal computers, to function within a network of computers, comprising for example: a computer with at least two microprocessors and having a connection means with a network of computers; the architecture for the computers including an internal firewall means for personal computers to limit access by the network to only a portion of the hardware, software, firmware, and other components of the personal computers; the internal firewall means will not permit access by the network to at least a one microprocessor having a means to function as a master microprocessor to initiate and control the execution of a computer processing operation shared with at least one other microprocessor having a means to function as a slave microprocessor; the internal firewall means permitting access by the network to the slave microprocessor; the configuration of the internal firewall being capable of change by a user or authorized local network administrator; the change in firewall configuration of a microchip PC is made at least in part using field-programmable gate arrays or equivalents or successors. In addition, the system architecture explicitly includes embodiments of, for example, the computer is a personal computer; the personal computer is a microchip; the computer has a control means by which to permit and to deny access to the computer by the network for shared computer

26

processing; the system is scalar in that the system imposes no limit to the number of personal computers, including at least 256 said personal computers; the network is connected to the Internet and its equivalents and successors, so that the personal computers include at least a million personal computers; the system is scalar in that the system imposes no limit to the number of personal computers participating in a single shared computer processing operation, including at least 256 said personal computers; the personal computers having at least one microprocessor and communicating with the network through a connection means having a speed of data transmission that may be at least greater than a peak, data processing speed of the microprocessor.

PC 1 or PC general purpose microprocessors 90 may be designed homogeneously to the same basic consensus industry standard as parallel microprocessors for PC's (or equivalents or successors) as in FIGS. 10A-10B or for PC "systems on a chip" discussed in FIGS. 10C-10D. Although the cost per microprocessor might rise somewhat initially, the net cost of computing for all users is expected to fall drastically almost instantly due to the significant general performance increase created by the new capability to use of heretofore idle "appliance" microprocessors. The high potential for very substantial benefit to all users may provide a powerful force to reach consensus on industry hardware, software, and other standards on a continuing basis for such basic parallel network processing designs utilizing the Internet 3 and WWW and successors. Such basic industry standards may be adopted at the outset of system design and for use of only the least number of shared microprocessors initially. Such basic industry homogeneous standards may be adopted at the outset and for the least number of shared microprocessors initially, and design improvements incorporating greater complexity and more shared microprocessors may be phased in gradually over time on a step-by-step basis, so that conversion to the Grid (or MetaInternet) or architecture at all component levels may be relatively easy and inexpensive. The scalability of the Grid (or MetaInternet) system architecture (both vertically and horizontally) as described herein makes this approach possible.

By 1998, manufacturing technology improvements allow 20 million transistors to fit on a single chip (with circuits as thin as 0.25 microns) and, in the next cycle, 50 million transistors using 0.18 micron circuits. That entire computer on a chip may be directly linked by fiber optic or wireless optic or other broad bandwidth connection means to the network so that the limiting factor on data throughput in the network system, or any part, may be only the speed of the linked microprocessors themselves, not the transmission speed of the network linkage. Such direct fiber or wireless optic linkage and integration of volatile memory (RAM like DRAM (dynamic random access memory) or equivalent), or non-volatile memory (like flash, magnetic, such as MRAM, or ovonic memory), on the "system on a chip" microchip obviates an increasingly unwieldy number of microchip connection prongs, which is currently in the three to four hundred range in the Intel Pentium and Pentium Pro series and will reach over a thousand prongs in the 1998 IBM Power3 microprocessor. One or more digital signal processors 89 and one or more all optical switches 92 located on a microprocessor 90 (or 30 or 40), together with numerous channels and/or signal multiplexing (such as wave division) of the fiber optic signal can substitute for a vast multitude of microchip connection prongs.

For computers that are not reduced to a single chip, the internal system bus or buses of any such PC's may have a transmission speed that is at least high enough that all pro-

cessing operations of the PC microprocessor or microprocessors are unrestricted (and other PC components like RAM such as DRAM) and that the microprocessor chip or chips are directly linked by fiber optic or other broad bandwidth connection, as with the system chip described above, so that the limiting factor on data throughput in the network system, or any part, is only the speed of the linked microprocessors themselves, not the transmission speed of the linkage.

The individual user PC's may be connected to the Internet (via an Intranet)/Internet II/WWW or successor, like the Grid (or MetaInternet) network by any electromagnetic or optical means, such as with the very high transmission speed provided by the broad bandwidth of optical connections like fiber optic cable. Hybrid systems using fiber optic cable for trunk lines and coaxial cable to individual users may be used. Given the speed and bandwidth of transmission of fiber optic or equivalent or successor connections, conventional network architecture and structures should be acceptable for good system performance, making possible a virtual, complete interconnection network between users.

However, the best speed for any parallel processing operation may be obtained, all other things being equal, by utilizing the available microprocessors that are physically the closest together. Consequently, as shown previously in FIG. 8, the network needs the means (through hardware and/or software and/or firmware and/or other component) to provide on a continually ongoing basis the capability for each PC to know the addresses of the nearest available PC's, perhaps sequentially, from closest to farthest, for the area or cell immediately proximate to that PC and then those cells of adjacent areas.

Network architecture that clusters PC's together, is not mandatory and can be constructed by wired means. However, as shown in FIG. 11, it may be very beneficial to construct local network clusters 101 (or cells) of personal computers 1' by wireless 100 means, especially optical wireless and dense wave division multiplexing (DWDM), since physical proximity of any PC 1 to its closest other PC 1' may be easier to access directly that way, as discussed further below. Since optical wireless range is about 3 kilometers currently, large clusters communicating with broadband connections are possible. In addition, at least several network providers may serve any given geographic area to provide competitive service and prices.

Those wireless PC connections may be PC-resident and capable of communicating by wireless or wired (or mixed) means with all available PC's in the cluster or cell geographic area, both proximal and potentially out to the practical limits of the wireless transmission.

As shown in FIG. 12, wireless PC connections 100 can be made to existing non-PC network components, such as one or more satellites 110, or present or future equivalent or successor components and the wireless transmissions can be conventional radio waves, such as infrared or microwave, or can utilize any other part of the electromagnetic wave spectrum, particularly including optical, and can utilize dense wave division multiplexing (DWDM) to create numerous channels.

Moreover, as shown in FIG. 13, such a wireless or wired approach also makes it possible to develop network clusters 101 of available PC's 1' with complete interconnectivity; i.e., each available PC 1 in the cluster 101 may be connected wirelessly 100 (including optical wireless and DWDM) to every other available PC 1 in the cluster 101, constantly adjusting to individual PC's becoming available or unavailable. Given the speed of some wired broad bandwidth connections, like fiber optic cable, such clusters 101 with virtual complete interconnectivity is certainly a possible embodiment even for PCs with wired connections.

As shown in FIG. 14A-14D, such wireless systems may include a wireless device 120 comprising hardware and/or software and/or firmware and/or other component, like the PC 1 availability device described above resident in the PC, but also with a network-like capability of measuring the relative distance from each PC 1 in its cluster 101 by that PC's signal transmission by transponder or its functional equivalent and/or other means to the nearest other PC's 1' in the cluster 101. As shown in FIG. 14A, this distance measurement could be accomplished in a conventional manner between transponder devices 120 connected to each PC in the cluster 101; for example, by measuring in effect the time delay from wireless transmission, optical or other and including DWDM, by the transponder device 120 of an interrogating signal 105 to request initiation of shared processing by a master PC 1 to the reception of a wireless transmission response 106 signaling availability to function as a slave PC from each of the idle PC's 1' in the cluster 101 that has received the interrogation signal 105. The first response signal 106' received by the master PC 1 is from the closest available slave PC 1" (assuming the simplest shared processing case of one slave PC and one master PC), which is selected for the shared processing operation by the requesting master PC 1, since the closer the shared microprocessor, the faster the speed of the wireless connections 100 is between sharing PC's (assuming equivalence of the connection means and other components among each of the PC's 1'). The interrogation signal 105 may specify other selection criteria also, for example, for the closest compatible (initially perhaps defined by a functional requirement of the system to be an identical microprocessor) slave PC 1", with the first response signal 106' being selected as above.

This same transponder approach also can be used between PC's 1" connected by a wired 99 (or mixed wired/wireless) means, despite the fact that connection distances would generally be greater (since not line of sight, as is wireless), as shown in FIG. 14A, since the speed of transmission by broad bandwidth transmission means such as fiber optic cable is so high as to offset that greater distance. From a cost basis, this wired approach may be employed for such PC's already connected by broad bandwidth transmission means since additional wireless components like hardware and software are not necessary. In that case, a functionally equivalent transponder device 120 may be operated in wired clusters 101 in generally the same manner as described above for PC's connected in wireless clusters 101. Networks incorporating PC's 1 connected by both wireless and wired (or mixed) means are anticipated, like the home or business network mentioned in FIG. 10I, with mobile PC's or other computing devices using wireless connections. Depending on distances between PC's and other factors, a local cluster 101 of a network 2 may connect wirelessly between PC's and with the network 2 through transponding means linked to wired broad bandwidth transmission means, as shown in FIG. 14C.

As shown in FIG. 14D, the same general transponder device means 120 can also be used in a wired 100 network system 2 employing network servers 98 operated, for example, by an ISP, or in any other network system architectures (including client/server or peer to peer) or any other topologies (including ring, bus, and star) either well known now in the art or their future equivalents or successors.

The FIG. 14 approach to establishing local PC clusters 101 for parallel or other shared processing avoids using network computers such as servers (and, if wireless, other network components including even connection means), so that the entire local system of PC's within a cluster 101 operates independently of network servers, routers, etc. Moreover,

particularly if connected by wireless means, including optical wireless and DWDM, the size of the cluster **101** could be quite large, being limited generally by PC wireless transmission power, PC wireless reception sensitivity, and local and/or other conditions affecting transmission and reception. Additionally, one cluster **101** could communicate by wireless **100** means with adjacent, overlapping, or other clusters **101**, as shown in FIG. **14B**, which could thereby include those beyond its own direct transmission range.

To improve response speed in shared processing involving a significant number of slave PC's **1**, a virtual potential parallel processing network for PC's **1** in a cluster **101** may be established before a processing request begins. This is accomplished by the transponder device **120** in each idle PC **1**, a potential slave, broadcasting by transponder **120** its available state when it becomes idle and/or periodically afterwards, so that each potential master PC **1** in the local cluster **101** is able to maintain relatively constantly its own directory **121** of the idle PC's **1** closest to it that are available to function as slaves. The directory **121** may contain, for example, a list of about the standard use number of slave PC's **1** for the master PC (which initially probably is just one other PC **1**) or a higher number, listed sequentially from the closest available PC to the farthest. The directory of available slave PC's **1** may be updated on a relatively up-to-date basis, either when a change occurs in the idle state of a potential slave PC in the directory **121** or periodically.

Such ad hoc clusters **101** should be more effective by being less arbitrary geographically, since each individual PC is effectively in the center of its own ad hoc cluster. Scaling up or down the number of microprocessors required by each PC at any given time is also more seamless.

The complete interconnection provided by such ad hoc wireless clusters is also remarkable because such clusters mimic the neural network structure of the animal brain, wherein each nerve cell, called a neuron, interconnects in a very complicated way with the neurons around it. By way of comparison, the global network computer described above that is expected in a decade can have at least about 10 times as many PC's as a human brain has neurons and they can be connected by electromagnetic waves traveling at close to the speed of light, which is about 300,000 times faster than the transmission speed of human neurons (which, however, are much closer together).

As individual PC's continue to become much more sophisticated and more network oriented, compatibility issues may decrease in importance, since all major types of PC's will be able to emulate each other and most software, particularly relative to parallel processing, may no longer be hardware-specific. However, to achieve maximum speed and efficiency, it is beneficial to set compatible hardware, software, firmware, and other component standards to realize potential performance advantages attainable with homogeneous parallel processing components of the global network computer.

Until that compatibility or homogeneity is designed into the essential components of network systems, the existing incompatibility or heterogeneity of current components increases the difficulty involved in parallel processing across large networks. Even so, the use of message passing interfaces (MPI) and parallel virtual machines (PVM), for example, has made massively parallel processing between heterogeneous personal computers fairly easy for uncoupled operations, as shown for example in the Beowulf operating system, Globus, and the Legion system, from which has been derived Applied Meta. Programming languages like Java provide a partial means for dealing with the heterogeneity problem, whereas Linux provides greater speed and efficiency. In

addition, using similar configurations of existing standards, like using PC's available on the Internet (with its vast resources) with a specific Intel Pentium chip with other identical or nearly identical PC components is probably the best way in the current technology to eliminate many of the serious existing problems that can easily be designed around using available technologies by adopting reasonable consensus standards for homogeneous specification of all parallel processing system components, both networks and computers. The potential gains to all parties with an interest far outweigh the potential costs.

The above described global network computer system has an added benefit of reducing the serious and growing problem of the nearly immediate obsolescence of PC and other computer hardware, software, firmware, and other components. Since the system above is the sum of its constituent parts used in parallel processing, each specific PC component becomes less critical. As long as access to the network utilizing sufficient bandwidth is possible, then all other technical, inadequacies of the user's own PC can be completely compensated for by the network's access to a multitude of technically available PC's of which the user will have temporary use.

Although the global network computer will clearly cross the geographical boundaries of nations, its operation is not likely to be unduly bounded by inconsistent or arbitrary laws within those individual states. There will be considerable pressure on all nations to conform to reasonable system architecture and operational standards generally agreed upon, since the penalty of potential exclusion from a global network computer system like the Internet/WWW is potentially so high as to not be politically possible any in any country.

As shown in FIG. **15**, because the largest number of user PC's are completely idle, or nearly so, during the night, it can be useful for the most complicated, large scale parallel processing, involving the largest numbers of processors with uninterrupted availability as close together as possible, to be routed by the network to geographic areas of the globe undergoing night and to keep them there even as the Earth rotates by shifting computing resources as the world turns. As shown in the simplest case in FIG. **15**, during the day, at least one parallel processing request by at least one PC **1** in a network **2** in the Earth's western hemisphere **131** is transmitted by very broad bandwidth connection wired **99** means such as fiber optic cable to the Earth's eastern hemisphere **132** for execution by at least one PC **1**' of a network **2**', which, is idle during the night, and the results are transmitted back by the same means to network **2** and the requesting at least one PC **1**.

Any number of individual PC's within local networks like that operated by an ISP can be grouped into clusters or cells, as is typical in the practice of the network industry. As is common in operating electrical power grids and telecommunications and computer networks, many such processing requests from many PC's and many networks could be so routed for remote processing, with the complexity of the system growing substantially over time in a natural progression.

Alternatively, for greater security or simplicity, nighttime parallel processing can remain within a relatively local area and emphasize relatively massively parallel processing by larger entities such as business, government, or universities for relatively complicated applications that benefit from comparatively long nightly periods of largely uninterrupted use of significant numbers of slave personal computers PC **1**.

Any of the embodiments, shown in FIGS. **1-15** can be combined with one or more of any other of FIGS. **1-15** of this application to provide a useful improvement over the art.

While the conventional approach to configuring a network of personal computers PC 1 for parallel processing is simply to string them together in a simple bus-type architecture, as shown previously in FIG. 9, FIGS. 16A-16Z and 16AA show a new hierarchical network topology.

Although the FIG. 9 network structure is simple and produces reasonable results in loosely coupled problems like geographic searches described earlier, as a general approach it has at least three important problems.

First, as the number of personal computers PC 1 being used in the network grows, an increasingly greater deal of complex pre-operation planning and custom tailoring-type programming at the master PC 1 level is required to establish a means for allocating portions of the operation among the large number of available personal computers PC 1'.

Second, operational results coming back to PC 1 from personal computers PC 1' are not synchronized, so that PC 1 frequently alternates between being idle and being overwhelmed. When the number of personal computers PC 1' is very large, both problems can be significant; when the number is massive, the problems can be overwhelming and seriously degrade the operation of the network.

Third, generally there are no means established for personal computers PC 1' to communicate or cooperate with each other during such network operations, so sharing operational results during processing between personal computers PC 1' is usually not feasible, especially when large numbers of PC 1 are involved. Consequently, closely coupled problems are generally not amenable to solution, by conventional parallel processing by computers using a simple bus-type network like FIG. 9.

The new hierarchical network topology shown in FIG. 16A is a simple subdivision step whereby a personal computer PC 1 (or equivalent PC on a microprocessor chip 90) or microprocessor 30 acting, as a master M_1 divides a given operation into two parts (for example, two halves), then sends by an optical or electrical connection such as optical fiber, or wire 99 the one half parts to each of two connected available slave personal, computers PC 1 (or PC microprocessor 90) or microprocessor 30, as shown one processing level down as S_{21} and S_{22} . The topology of FIG. 16A (and subsequent FIG. 16) can be connected to the Internet 3 and World. Wide Web, for example.

FIG. 16B shows that slave personal computer PC 1 (or PC microprocessor 90) or microprocessor 40 located at S_{21} has temporarily adopted the same functional role as a master to repeat the same subdivision of the given operation. Therefore, having already been divided in half once in FIG. 16A, the given operation is again subdivided in FIG. 16B, this time in half into quarters of the original operation (for example) by S_{21} , which then sends one quarter to each of two additional available slave personal computers PC 1 (or PC microprocessors 90) or microprocessors 40 located at S_{31} and S_{32} .

FIG. 16C shows personal computers PC 1 (or PC microprocessor 90) or microprocessors 40 at S_{31} and S_{32} sending operational results back to S_{21} after performing the processing required by the given operation, instead of repeating again the subdivision process. That processing action by S_{31} and S_{32} can be dictated by pre-established program criteria, for example by automatically defaulting to operational processing at the S_3 level after two subdivision processes as shown above, so that the operation can be processed in parallel by four available slave personal computers PC 1 (or PC microprocessors 90) or microprocessors 40. Alternately, as another example, the criteria can be a user preference command overriding an otherwise automatic default to level three process-

ing in order to specify some other level of processing involving more or less, slave PC 1 (or PC microprocessors 90) or microprocessors 40.

Similarly, in FIG. 16A above, the personal computer PC 1 (or PC microprocessor 90) or microprocessor 40 acting as master M_1 also can initiate the parallel processing operation (or, alternatively, a multi-tasking operation) on the basis of preset program parameters through software, hardware, or firmware or other means; parameter examples again may be pre-set automatic default or user preference override.

Like FIG. 16C, FIG. 16D shows operational results being passed back to the next higher level, this time from slave personal computers PC 1 (or PC microprocessors 90) or microprocessors 40, S_{21} and S_{22} , to master personal computer PC 1 (or PC microprocessor 90) or microprocessor 30, M_1 , where the operation is completed after the S_{21} and S_{22} results are consolidated.

FIG. 16G shows master personal computer PC 1 (or PC microprocessor 90) or microprocessor 30, M_1 , offloading by wireless connection 100, such as optical wireless and DWDM for example, the entire parallel processing operation to an available slave personal computer PC 1 (or PC microprocessor 90) or microprocessor 40 that temporarily functions as S_1 in the place of M_1 on the first processing level for the duration of the given parallel processing (or multi-tasking) operation, the first step of which the operation is shown in FIG. 16H, which is like FIG. 16A except as shown.

FIG. 16I shows a personal computer PC 1 (or PC microprocessor 90) or microprocessor 40 that is executing a command to function in the slave role of S_{21} for a given operation but has become unavailable, or was unavailable initially (due, for example, to interruption for another higher priority command by its user or to malfunction), when results of the given operation from a lower parallel processing level are passed to S_{21} . In that situation, S_{21} (or S_{31} or S_{32}) can simply offload those results to another personal computer PC 1 (or PC microprocessor 90) or microprocessor 30 (or 40) that is then available and it can become S_{21} and take over the role of S_{21} in the given operation for the duration of that operation. Similarly, the role of any unavailable or malfunctioning master or slave PC 1 or microprocessor 90, 30, or 40 can be transferred to an available functioning one.

As shown in FIG. 16J, S_{21} then completes the parallel processing operation and passes its portion of the operational results to M_1 .

The offloading capability of functional roles of master and slave personal computers PC 1 (and PC microprocessors 90) and microprocessors 30 (and 40) from unavailable to available PC 1, 30 and 40 as shown in FIGS. 16G-16J can also be used in previous figures in this application. In the simplest case initially, all processing roles of personal computers PC 1 (and PC microprocessors 90) and microprocessors (30 or 40), like S_{21} , above can be determined at the beginning of an operation based on availability (based on non-use and lack of malfunctioning component) and remain unaltered until the end of the operation. But, with more sophisticated system software and hardware and firmware, during an operation any number of the processing roles can be offloaded from personal computers PC 1 (or PC microprocessors 90) or microprocessors 30 (or 40) to others as required, even multiple times and many simultaneously.

FIG. 16E shows the multi-processing network topology of FIGS. 16A-16J in a larger scale embodiment, including all personal computers PC 1 (or PC microprocessors 90) or microprocessors 30 (or 40) that are participating in a typical operation, including in this example one personal computer PC 1 (or PC microprocessor 90) or microprocessor 30 (or 40)

at level one; two at level two; four at level three; and, eight at level four. The network topology is completely scalar in that any practical number of additional processing levels or personal computers PC 1 (or PC microprocessors 90) or microprocessors 30 (or 40) can be added to those shown. Topologies limited to just two (or three) levels are also possible, which is the simplest case of operation processing subdivision that distinguishes over the conventional FIG. 9 single level "string-together" architecture.

The number of processing personal computers PC 1 (or PC microprocessors 90) or microprocessors 40 doubles at each additional processing level and therefore can be represented by 2^N , where N is the last or final processing level, for the simplest case, as shown above, which is splitting one given operation into two parts such as halves between each level.

Instead of subdividing one operation as above, two separate parallel processing operations can be multi-tasked on separate branches, such as S_{21} and S_{22} as shown, using the same network architecture described above. As is clear from this example, any practical mix of multi-tasking and/or, parallel processing is possible using the above network architecture.

FIG. 16E shows the distribution of a given parallel processing (or multi-tasking) operation as routed through a four level virtual network, beginning at M_1 . "Virtual" as used here means temporary, since in the next parallel operation originating at M_1 it may be the case that many of the personal computers PC 1 (or microprocessors 90) or microprocessors 30 (or 40) that had been available for a previous operation would not still be available for the next operation.

FIG. 16E shows a binary tree network architecture for the initial distribution of an operation from M_1 down through four slave processing levels, while FIG. 16F shows the subsequent processing and accumulation of results back from there to M_1 . FIG. 16F shows an inverted view of FIG. 16E to show the sequence of the operation, from operation distribution in FIG. 16E to result accumulation in FIG. 16F.

More specifically, FIG. 16F shows the processing slave personal computers PC 1 (or PC microprocessors 90) or microprocessors 40 at the fourth level, S_{41} through S_{48} , where they process the operation to produce results which are then routed back through two other levels of the virtual network to M_1 .

In the routing of operational results shown in FIG. 16F, each slave personal computer PC 1 (or PC microprocessor 90) or microprocessor 40 has the capability to either simply pass through those results only as a direct communication link or connection; or, alternatively, for example, to consolidate those results sent from the personal computers PC 1 (or PC microprocessor 90) or microprocessors 40 at a lower level; or, to provide additional other processing based on those lower processing level results.

Such consolidation or additional processing can reduce or eliminate duplicative data from a search or other operation producing duplicative results and can also serve to buffer the originating master M_1 from overloading caused by many sets of results arriving at M_1 in the FIG. 9 single processing level architecture in an uncoordinated fashion from what may be a large number of slave personal computers PC 1 (or PC microprocessor 90) or microprocessors 40. Such a consolidation role for personal computers PC 1 (or PC microprocessor 90) or microprocessors 40 substantially reduces or eliminates the excessive custom pre-planning and synchronization problems of the conventional FIG. 9 network topology discussed above.

FIG. 16K shows a simple example indicative of the extremely complicated network structure that can result from

subdividing a given operation in which the complexity of the operation involved is not uniform, due to, for example, variations in the data. In this example, pre-set program splitting criteria can be employed that balances the processing load of each slave personal computer PC 1 (or PC microprocessor 90) or microprocessor 40. With this approach, the complex portions of a given operation can automatically draw greater resources in the form of additional splitting of that more difficult portion of the problem, so that additional levels of parallel processing slave personal computers PC 1 (or PC microprocessors 90) or microprocessors 40 can be brought into the virtual network to process the operation, as shown in the left branch of FIG. 16K.

FIG. 16K is a fairly simple example, but when the same kind of dynamic network structure is applied to a virtual network using many more personal computers PC 1 (or PC microprocessor 90) or microprocessors 30 or 40 and many processing levels, involving both micro levels in PC microprocessor chips 90 and macro levels in personal computers PC 1 networks (such as shown later in FIG. 20B), then the potential complexity of the virtual network increases significantly. For example, each PC microprocessor chip 90 may have 64 slave microprocessors 94 on the final processing level; each personal computer PC 1 may have 64 slave PC microprocessor chips 90 at the final processing level, and the virtual network may include 64 personal computers PC 1 at the final processing level. With this large number of physical resources available (which can of course be very substantially greater) to the virtual network created by processing a given operation or operations, like that shown in FIG. 16K, it is clear that the operation itself can sculpt an incredibly complex virtual network that is custom tailored to the specific operation. All that is required is a operation subdivision process as described earlier that can be resident in each PC 1 (or PC microprocessor 90) or microprocessor 30 or 40, or that can be passed along with data (as can be operation application software) as the operation is executed.

Thus, FIG. 16K shows an example of a highly flexible virtual network architecture that is capable of being dynamically configured in real time by the processing requirements imposed on the components of the network by a specific given operation and its associated data, as allowed by the network hardware/software/firmware architecture.

FIGS. 16L and 16M show examples of other possible subdivision parallel processing methods, such as subdivision routing to three slave personal computers PC 1 (or PC microprocessors 90) or microprocessors 40 at the next level down, as shown in FIG. 16L, or subdivision routing to four slave personal computers PC 1 (or PC microprocessors 90) or microprocessors 40, as shown in FIG. 16M. Subdivision routing to any practical number of slave personal computers PC 1 (or PC microprocessors 90) or microprocessors 40 between processing levels can be done.

Such routing subdivision can also vary between processing levels or even within the same processing level, as shown in FIG. 16N; these exemplary variations can result from pre-set program criteria such as those that balance operational loads, like those shown previously in FIG. 16K. The means for subdividing problems for parallel or multi-tasking processing can also vary, within at least arrange of methods known in the computer and mathematical arts.

FIG. 16O shows slave personal computer PC 1 (or PC microprocessor 90) or microprocessor 40, S_{41} , sending operational results to a higher processing level, S_{31} , which can then function as a router or as one or more high speed switch 42 (which can be located as 92 on a PC microprocessor 90 also, including as an all optical switch), passing through

unaltered results back down to the original level to personal computer PC 1 (or PC microprocessor 90) or microprocessor 40, S₄₂, as shown in FIG. 16P. FIG. 16Q demonstrates the capability for any two pair of slave personal computers PC 1 (or PC microprocessors 90) or microprocessors 40 like S₄₁ and S₄₂ to communicate directly between each other, including wired or wirelessly 100 as shown. FIGS. 16O-16Q show the same subsection of the network topology shown in FIG. 16F (the left uppermost portion).

A personal computer. PC 1 (or PC microprocessor 90) or microprocessor 30 (or 40) located on a higher processing level in the network architecture such as S₃₁ can process results as well as route them, as shown in FIG. 16V, in which S₃₁ receives results from S₄₁ and S₄₂ at a lower processing level and then, processes that data before sending its processing results to a higher level to S₂₁, as shown in FIG. 16W.

Together, FIGS. 16V-16W and 16O-16Q show the capability of any personal computer PC 1 (or PC microprocessor 90) or microprocessor 30 (or 40) of the FIGS. 16F (and 16E) network structural and functional invention to communicate with any other personal computer PC 1 (or PC microprocessor 90) or microprocessor 30 (or 40) participating in a given parallel processing (or multi-tasking) operation. That communication can take the form of simple pass-through of unmodified results or of modification of those results by processing at any level.

FIGS. 16X-16Z show the applicant's new hierarchical network structure and function applied to the design of a personal computer PC 1, as discussed previously in FIGS. 10A and 10B. FIG. 16X shows the simplest general design, with a master M₁ microprocessor 30 and two slave S₂₁ and S₂₂ microprocessors 40. FIG. 16Y shows the same network structure with an additional level of slave microprocessors 40, S₃₁ through S₃₄, while FIG. 16Z shows the same network structure as FIG. 16Y with an additional level of slave microprocessors 40, S₄₁ through S₄₈. As shown in these examples, this network structure is completely scalar, including any practical number of slave microprocessors 40 on any practical number of processing levels.

FIG. 16AA shows a useful embodiment in which each microprocessor 30 and 40 has, in addition to internal cache memory, its own random access memory (RAM) 66 or equivalent memory (volatile like DRAM or non-volatile like Flash memory, magnetic such as MRAM memory, or ovonic unified memory), integrated on-microchip 90 or separate off-microchip. A significant amount of such microchip RAM (volatile like DRAM or non-volatile like Flash memory, magnetic such as MRAM memory, or ovonic unified memory), significantly greater than cache memory (SRAM) and other on-chip memory used on microprocessor chips today; can be beneficial in improving the efficient operation of the microprocessor; if located off microprocessor chip, the size of such memory can substantially exceed the size of the associated microprocessor, but an on-microprocessor chip location for DRAM or Flash (or MRAM or ovonic memory), like cache (SRAM) memory, offers the best potential for improving microprocessor speed and efficiency. The design can also incorporate (or substitute) conventional shared memory or RAM 66' (i.e. memory used by all, or some, of the microprocessors 30 or 40 (or 90) of the personal computer PC 1).

FIGS. 16R-16T are parallel to FIGS. 16X-16Z above, but show PC microprocessor 90 architecture rather than macro PC 1 architecture; a PC microprocessor 90 is as earlier described in FIG. 10C, a personal computer on a microchip.

FIG. 16U is like FIG. 16AA, also except for showing PC microprocessor 90 architecture instead of PC 1 architecture. FIG. 16U shows a useful embodiment in which each PC

microprocessor 93 or 94 has its own integrated on-microchip (or separate off microchip) random access memory (RAM) 66 or equivalent memory (volatile like DRAM or non-volatile, like Flash memory, magnetic such as MRAM memory, or ovonic unified memory). A significant amount of such RAM or other memory, significantly greater than cache (SRAM) memory or other on-microchip memory used on microprocessor chips today, can be beneficial in improving the efficient operation of the microprocessor; if located off-microprocessor chip, the size of such memory can substantially exceed the size of the associated microprocessor, but anon-microprocessor chip 90 location for DRAM or Flash (or MRAM or ovonic memory), like cache (SRAM) memory, offers the best potential for improving microprocessor speed and efficiency. The microchip design can also incorporate (or substitute) conventional shared memory or RAM 66' (i.e. memory used by all, or some; of the PC microprocessors 93 or 94 of the personal computer PC microprocessor 90).

FIGS. 16R-16U show a different and improved basic microchip architecture which can exclude or reduce the currently used superscalar approach in microprocessors to execute multiple instructions during each clock cycle. The FIGS. 16R-16U architecture is much simpler and, by integrating memory with microprocessor, reduces memory bottlenecks. The simplicity of the FIGS. 16R-16U microchip design, which may have little or no superscalar components, compared to conventional superscalar designs (the inherent extreme complexity of which creates a very substantial memory overhead), can result in the use of a much greater proportion of independent, non-superscalar processors per microchip, exclusive of integrating memory or RAM 66 onto the microprocessor chip 90, as discussed in FIG. 16U.

FIGS. 16X-16Z and 16AA, by using the same architecture for PC 1 networks as FIGS. 16R-16U, import the same advantage of microchip parallel processing performance to parallel processing in PC 1 networks.

FIG. 16AB shows a direct connection of optical fiber 99 from Internet 3 (or another network) to random access memory (RAM) microchip 66'. The connection may be at a central portion 140 of RAM chip 66' to provide equal access to stored data on RAM chip 66'. The direct connection can be anywhere on RAM chip 66'. Digital signal processor (DSP) 89 is on RAM chip 66' for connection with optical fiber 99. RAM chip 66' is for shared memory use among PC's 1 and for broadcast use. RAM chip 66' can include volatile or non-volatile (flash-type) memory. RAM chip 66' can have more than one DSP 89, such as shown in FIG. 20B.

All FIGS. 16A-16Z and 16AA-16AB, like the preceding figures of this application, show sections of a network of personal computers PC 1 (or PC microprocessors 90) or microprocessors 30 or 40 which can be parts of the WWW or Internet or Internet II or the Next Generation Internet (meaning connected to it) or Intranets or Extranets or other networks.

Also, except for FIGS. 16R-16T and 16X-16Z, all of the FIG. 16 series show personal computers PC 1 and microprocessors 30 or 40 as occupying the same location. This dual representation was done for economy of presentation and to show the parallel functionality and interchangeability in conceptual terms of personal computer PC 1 and microprocessors 30 or 40 in the structure of the new network. So, taking FIG. 16A as an example, M₁, S₂₁ and S₂₂ show three personal computers PC 1 or, alternatively, one microprocessor 30 and two microprocessors 40.

As noted initially in FIG. 10C, a personal computer PC 1 can be reduced in size to a PC microprocessor chip 90, so

preceding Figures showing personal computer PC 1 also generally represent PC microprocessor chip 90.

Finally, FIGS. 16A-16Z and 16AA-16AB show a mix of electrical and optical connections, including wired 99, especially connections such as optical glass fiber or omniguide, 5 and wireless 100, especially wireless optical (and mixtures of both in a single figure), and dense wave division multiplexing (DWDM). Generally, either 99 or 100 or a mix can be used relatively interchangeably in the network inventions shown (as well as in prior figures), though in some embodiments either highest transmission speed (i.e. broadest bandwidth) or mobility (or some other factor) may dictate a use of wired or wireless. Generally, fiber optic wire 99 and dense wave division multiplexing (DWDM) may provide the most advantageous transmission means because it has the greatest bandwidth or data transmission speed, so it may be used for connections between personal computers and microchips, including direct connections, although optical wireless 100 also offers very high bandwidth, especially with dense wave division multiplexing (DWDM). Other wireless 100 (but also including optical wireless), including with DWDM, can be used where mobility is a paramount design criteria.

The FIG. 16 embodiments can be combined with, or modified by incorporating, any other network system architectures (including client/server or peer to peer) or any other topologies (including ring, bus, and star) either well known now in the art or their future equivalents or successors.

Any of the embodiments shown in FIGS. 16A-16Z and 16AA-16AB can be combined with any one or more of the preceding or subsequent figures of this application to provide a useful improvement over the art.

The parallel processing network architecture shown in the preceding FIGS. 16A-16Z and 16AA-16AB and in earlier figures has several features unique to its basic design that provide for the security of personal, computers PC 1 (or PC microprocessor 90) or microprocessor 40 that share other computers for parallel and multi-tasking processing. First, the slave personal computers PC 1 (or microprocessors 40) each have only part of the operation (for large operations, only a very small part) and therefore unauthorized surveillance of a single PC 1 can provide only very limited knowledge of the entire operation, especially in only a relatively local area in which switching or routing was employed. Second, the addresses of the slave personal computers PC 1 (or microprocessors 40) are known or traceable, and therefore are not protected by anonymity (like hackers usually are) in case of unauthorized intervention. In addition, cryptography can be employed, with on microprocessor chip 30, 40, or 90 hardware 55 being used in some embodiments due to efficiency, although software and firmware can also be used, or a separate PC 1 hardware-based component 56 like an encryption microchip can be used; with either encryption component 55 or 56, micro electromechanical locks can be used to prevent access other than by the direct physical user; other Micro-ElectroMechanical System (MEMS) devices located on microchips like PC90 can be used for access prevention or other functions. Nonetheless, these inherent strengths can be substantially reinforced, as indicated in FIGS. 17B-17D.

FIG. 17A shows at least one internal firewall 50 performing its conventional function of keeping out intruders such as hackers from the Internet 3 from unauthorized access for either surveillance of, or intervention in, a user's personal computer PC 1 (or PC microprocessor 90) or master microprocessor 30.

FIG. 17B shows that, since Internet users can, as enabled by the applicant's network structure invention, use one or more of the slave microprocessors 40 of another's personal

computer PC 1 (or PC microprocessor 90) for parallel (or multi-tasking) processing, the at least one internal firewall 50 has a dual function in also protecting Internet 3 use (or other shared use on a network) from unauthorized surveillance or intervention by a PC 1 owner/user who is providing the shared resources. To maintain the privacy necessary to operate such a cooperatively shared network arrangement, unauthorized surveillance or intervention must be carefully prevented by hardware/software/firmware or other means.

FIG. 17C therefore shows master M personal computer PC 1 (or PC microprocessor 90) using the slave S₂ microprocessor 40 of a different personal computer, PC 1', which is available for Internet 3 (or other net) shared use, while internal firewall 50' blocks unauthorized access into PC 1' by PC 1 (although PC 1' owner/user can always interrupt a shared operation and take back control and use of slave S' microprocessor 40, which then triggers off-loading action to compensate, as discussed above in FIGS. 16I-16J).

FIG. 17D is similar to FIG. 17C, but shows a PC microprocessor 90 with a slave microprocessor 94 being used by Internet 3 users (or other net), so that at least one firewall 50 serves both to deny access such as surveillance by master M microprocessor 93 to an Internet 3 parallel processing (or multi-tasking) operation on slave S microprocessor 94 and to deny access to master M microprocessor 93 by Internet 3 (or other net) users of slave S microprocessor 94. At least one internal firewall 50 may be implemented by non-configurable hardware at the microchip level to provide protection against tampering with the internal firewall 50 by a PC 1 user, who has easier access to software or macro hardware such as PC motherboards to alter. PC 90 microchips may employ tamper-resistant construction or tamper-proof construction. As such, PC 90 microchips may be permanently locked by out-of-specification conditions or permanently destroyed by attempts at physical access.

Also, non-configurable hardware denying access from the network is the most immune to hacking from any outside source, including the Internet, and can therefore be used either for general protection or to protect an innermost kernel of the most confidential of personal files (such as passwords or financial data) and the most critical of operating system components, such as the system bios or access to file alternation.

At the same time, the FIG. 17 and earlier embodiments provide a solution to digital rights management by providing a highly safe environment for the owners of digital versions of audio, video, and software copyrighted material. Such copyrighted material as movies, television, music, and application or operating system software may be decrypted and controlled on the network user side of the PC 1 or PC 90, while the PC 1 user is denied access to the decrypted, digital version of the copyrighted material. However, the network user can make the material viewable to the PC 1 user, but not copyable, via the PC 1 and PC 90 microchip architecture shown in FIGS. 10A and 10C.

Any of the embodiments shown in FIGS. 17A and 17B can be combined with one or more of any of the preceding figures of this application to provide a useful improvement over the art.

The flexible network architectures shown earlier in FIG. 16K and other FIG. 16 series (and other figures) have many applications and may be used to design improvements and alternatives to the network itself. In addition, the flexible network can be used to simulate and design personal computers PC 1 and particularly PC microprocessor chips 90 (and other microchips), which may be static or configurable (in

response to the requirements of a given operation, like the FIG. 16K network architecture) or a mix.

The FIG. 16K network architecture has capabilities that substantially exceed simulating the fairly simple binary circuit structure of a typical PC microprocessor 90 or other microchip, since any personal computer PC 1 or PC microprocessor chip 90 in the FIG. 16K network can simulate much more than a simple binary circuit on/off state or other simple microchip circuit. Any PC 1 or PC microprocessor chip 90 in a FIG. 16K network can represent virtually any number of states or conditions simulating any kind of circuit, however complex it might be, the only limit being the processing time required for what can be a very large number—thousands or millions—of personal computers PC 1 or PC microprocessors 90 to process the simulation; there are only practical constraints, not theoretical ones, although increasingly large numbers of processors are expected to be phased in, as discussed before.

One potential related application of prior described network inventions is to simulate the unique “qubit” component necessary to construct a quantum computer, as well as a virtual quantum computer itself.

FIGS. 18A-18D show designs for a virtual quantum computer or computers. FIG. 18A shows personal computer PC 1 (or microprocessor 90) with the addition of a software program 151 simulating a “qubit” for a quantum computer or computers and thereby becoming a virtual qubit (VQ) 150, a key component of a quantum computer 153. FIG. 18B shows a personal computer PC 1 (or microprocessor 90) with a digital signal processor (DSP) 89 connected to a hardware analog device 152 simulating a qubit, with the PC 1 monitoring the qubit through the DSP 89, thereby simulating a virtual qubit (VQ) 150 for a quantum computer 153; this arrangement allows the option of simultaneous use of the PC 1 through Multi-tasking for both digital and quantum computing.

FIG. 18C is like FIG. 16A, but incorporates a virtual qubit in PC 1, so that a virtual quantum computer 153 can have any network architecture like those shown in FIGS. 16A-16Z and 16AA-16AB, as well as other figures of this application.

As shown in FIG. 18D, for example, a virtual qubits (VC) 150 network can provide complete interconnectivity, like FIG. 13. Virtual qubits VC 150 like those described in FIGS. 18A & 18B can be added to or substituted for microprocessors 30 and 40 in prior FIGS. 16B-16Q and 16V-16AA of this application, as well as earlier figures. As shown by those prior figures, the number of virtual qubits 150 is limited only to whatever is practical at any given time; in terms of development, that means as few as a single qubit 150 in one or more networked personal computers PC 1 to begin, but the number of qubits 150 may become extremely large, as indicated in previous figures. FIG. 18D shows a mix of wired 99 and wireless 100 connections.

Any of the embodiments shown in FIGS. 18A-18D can be combined with one or more of any of the preceding figures of this application to provide a useful improvement over the art.

Like personal computers located in the home or office, personal computers PC 1 in automobiles 170 (including other transportation vehicles or other conveyances) are in actual use only a very small percentage of the time, with the average dormant period of non-use totaling as much as 90 percent or more. Personal, computers PC 1 are now being added to some automobiles and will likely become standard equipment over the next decade or so. In addition, automobiles already have a very large number of microcomputers on board in the form of

specialized microprocessors 35 which are likely to become general parallel processors in future designs, as discussed earlier in this application.

Automobiles therefore form a potentially large and otherwise unused resource for massive parallel processing through the Internet 3 and other networks, as described in earlier figures. However, when idle and thus generally available for network use, automobiles lack their usual power source, the engine, which of course is then off, since it is too large to efficiently provide electrical power to on board computers, except occasionally. As shown in FIG. 19, the car engine can have a controller (hardware, software or firmware) or combination in the PC 1 or other microprocessor 35, for example, connected to an automobile computer network 178 to automatically start the automobile engine in order to recharge the car battery 171 when the battery is low (and well before the battery is too low to start the engine), but the engine additionally needs to be controlled as above not to expend all available fuel automatically.

Alternately, the automobile 170 can be fitted with a very small auxiliary engine-power electrical power generator 177 to provide power to the automobile’s computer network; the engine of the generator 177 can be fed by the main engine fuel tank and controlled as above.

Two solutions, not mutually exclusive, to alleviate (but not solve) the lack of power problem noted above are, first, adding an additional car battery 171' for network use (at least primarily) or, second, using a single battery but adding a controller in the PC 1, for example, that prevents the existing battery 171 from being discharged to a level near or below that which is needed to start the automobile 170.

In addition, as shown in FIG. 19, one or more solar power generating cells or cell arrays 172 can be incorporated in an automobile’s outer surface, with generally the most effective placement being on a portion of the upper horizontal surface, such as a portion of the roof, hood, or trunk. For charging the automobile battery 171 when sunlight is not available, such as at night or in a garage, a focused or focusable light source 173 can provide external power to the solar panel.

Alternately, a connection device 174 such as a plug for an external electrical power source can be installed on or near the outer surface of the automobile. In addition, or independently, a connection device 175 for an optical fiber (or other wired) external connection to the Internet 3 or other net may be used; an intermediate high transmission speed can also exist between the automobile network and a fiber optic connection to the Internet 3. Alternately, a wireless receiver 176, including optical wireless and/or DWDM, located near where the automobile is parked, such as in a garage, can provide connectivity from the automobile’s personal computer or computers PC 1 directly to the Internet 3 or to a network in a home or business like that shown in FIG. 101.

Any of the embodiments shown in FIG. 19 can be combined with one or more of any of the preceding figures of this application to provide a useful improvement over the art.

FIG. 20A is like FIG. 16Y (and can be combined with FIG. 16AA), but in addition shows a slave microprocessor 40 functioning as S_1 , the function of master having been temporarily or permanently offloaded to it by M_1 microprocessor 30. In addition, FIG. 20A shows the processing level of slave microprocessors 40, $S_{3,4}$ through $S_{3,4}$, each with a separate output/input communication link to a digital signal processor (DSP) 89 or other transmission/reception component; the transmission linkages are shown as 111, 112, 113, and 114, respectively. The DSP 89 can be connected to a wired 99

means such as optical fiber to the Internet (or other net), although non-optical fiber wire can be used (and probably does not require a DSP 89).

FIG. 20B is like FIG. 16S (and can be combined with FIG. 16U), but with the same new additions described above in FIG. 20A. Like FIG. 16S, FIG. 20B shows a detailed view of personal computer PC microprocessor 90₁, which is a personal computer PC on a microchip 90, including two more levels of parallel processing within the microprocessor 90. In addition, the two new levels of PC microprocessor 90 shown in FIG. 20B are a second processing level consisting of PC microprocessors 90₂₁ through 90₂₄ and a third processing level consisting of PC microprocessors 90₃₁ through 90₃₁₆ (a third level total of 16 microprocessors 90). Each of the three processing levels shown in the FIG. 20B example is separated between levels by an intermediate direct connection to the Internet 3 (or other network) and by four output lines from the higher processing level. For example, microprocessors 90₂₁ through 90₂₄ are shown receiving respectively from the outputs 111 through 114 from four slave microprocessors 94, S₃₁ through S₃₄ of PC microprocessor 90₁.

PC microprocessor 90₁ is shown in detail including all slave microprocessors 94, while other PC microprocessors 90 at the second and third processing levels are not, for simplicity and conciseness of presentation. An additional processing level can be present, but is not shown for the sake of simplicity, and personal computers PC 1 like FIG. 20A can be used interchangeably with PC microprocessors 90.

FIG. 20B shows that between each processing level the output links from every PC microprocessor 90 can be transmitted from, slave microprocessors 94 directly to PC microprocessors 90 at the next processing level below, such as from PC microprocessor 90₂₁ down to PC microprocessors 90₃₁ through 90₃₄, via the Internet 3 or other net. Each of the transmission/reception links from those slave processing microprocessors 94 (S₃₁ through S₃₄), shown as 111, 112, 113, and 114 for PC microprocessor 90₁, can be transmitted or received on a different channel (and can use multiplexing such as wave or dense wave division, abbreviated as DWDM) on an optical fiber line (because of its huge capacity, one optical fiber line is expected to be sufficient generally, but additional lines can be used) that may connect directly to PC microprocessor chip 90₁, which can incorporate a digital signal processor 89 or other connection component (of which there can be one or more) for connecting to the wired connection like fiber optic line, as shown, or wireless connection.

Any of the embodiments shown in FIGS. 20A and 20B can be combined with one or more of any of the preceding figures of this application to provide a useful improvement over the art.

FIGS. 21A and 21B are like FIGS. 20A and 20B (and therefore also can be combined with FIGS. 16AA and 16U, respectively), but show additionally that all microprocessors 30, 40, 93, and 94 of PC 1 or PC 90₁ can have a separate input/output communication link to a digital signal processor (DSP) or other transmission/reception connection component. The additional communications linkages are shown as 141, 142, 143, and 144, which connect to M₁, S₁, S₂₁, and S₂₂, respectively, and connect to the network, including the Internet 3, the WWW, the Grid, and equivalents or successors. Like all preceding and subsequent figures, FIGS. 21A and 21B are schematic architectural plans of the new and unique components of the parallel processing system invention disclosed in this application and can represent either physical connections or virtual relationships independent of hardware.

FIG. 21B shows an embodiment in which the additional linkages lead through the Internet 3 to microprocessors PC 90₂₅-90₂₈.

The additional communications linkages 141, 142, 143, and 144, as well as the original linkages 111, 112, 113, and 114 of FIGS. 20A and 20B, may have a bandwidth sufficiently broad to at least avoid constraining the processing speed of microprocessors 30, 40, 93, and 94 connected to the linkages. The ultra high bandwidth of optical connections like optical fiber or omniguides or optical wireless may provide external connections between PC 1 and PC 90₁ microprocessors that are far greater than the internal electrical connections or buses of those microprocessors, for example, by a factor of 10, or 100, or 1000, which are already possible with optical fiber, or 1,000,000, which is possible with optical omniguides, which are not limited to a relatively smaller band of wavelengths using DWDM like optical fiber, future increases will be substantial since the well established rate of increase for optical bandwidth is much greater than that for microprocessor speed and electrical connections. Wireless optical antennas that are positioned on the exterior of houses, buildings, or mobile reception sites, instead of inside of glass or other windows, should significantly increase the number of optical wavelengths that can be sent or received by each of the wireless optical antennas; the entire connection is freespace optical wireless, which allows for greater dense wave division multiplexing (DWDM) and thereby greater bandwidth.

A major benefit of the embodiments shown in FIGS. 21A-21B is that PC 1 and PC 90₁ can function like the FIG. 9 embodiment to efficiently perform operations that are uncoupled, so that each microprocessor M₁, S₁-S₃₄ can operate independently without microprocessors M₁, S₁, and S₂₁-S₂₂ being idled, as they may be in FIGS. 20A and 20B. Another benefit is that for tightly coupled parallel operations, microprocessors M₁, S₁, and S₂₁-S₂₂ can have broad bandwidth connections with microprocessors 30, 40, 93, or 94 that are not located on PC 1 or PC 90₁. Thus the embodiments shown in FIGS. 21A and 21B provide an architecture that allows PC 1 or PC 90₁ the flexibility to function in parallel operations either like FIGS. 20A-20B embodiments or like the FIG. 9 embodiment, depending on the type of parallel operation being performed. Studies indicate that single chip multiprocessors like PC 90₁ can also perform uniprocessor operations with a speed like that of uniprocessor architectures like wide-issue superscalar or simultaneous multithreading.

Like FIGS. 20A and 20B, the embodiment of FIGS. 21A and 21B includes broad bandwidth connection to the Internet 3 by wired means such as optical connection by fiber optic cable or omniguide or optical wireless, although other wired or non-wired means can be used with benefit, and the use of DWDM or wideband CDMA is clearly advantageous. It should be noted that the architecture of the FIGS. 20 and 21 embodiments may be particularly advantageous with ultrawideband communication connections.

Another advantage of the embodiments shown in FIGS. 22A and 22B when functioning in the FIG. 9 form of loosely coupled or uncoupled parallel processing or multitasking is that if PC 1 or PC 90₁ is functioning as a web server and typically uses only one microprocessor to do so, it can quickly add mirror web sites using one or more additional microprocessors to meet increasing volume of visits or other use of the web site. This replication of web sites on additional microprocessors in response to increasing load can also be done using the FIG. 16 form of tightly coupled parallel processing. PC 1 and PC 90₁ or any of their microprocessors 30, 40, 93,

and 94 or other components can also serve as a switch or a router, including other associated hardware/software/firmware network components.

Any of the embodiments shown in FIGS. 21A and 21B can be combined with one or more of any of the preceding figures of this application to provide a useful improvement over the art.

Binary tree configurations of microprocessors shown in FIGS. 16, 20, 21A, and 21B can be laid out in 2D using an H-tree configuration, as shown in FIG. 21C, and can be combined with one or more of any of the preceding figures of this application to provide a useful improvement over the art.

FIG. 22A shows a microprocessor PC 90₁ like that of FIG. 21B, except that FIG. 22A shows the microprocessors 93 and 94 each connecting to an optical wired interconnection 99' such as thin mirrored hollow wire or omniguide or optical fiber (and other very broad bandwidth connections can be used); the interconnect can include a digital signal processor 89' employed with a microlaser 150, which can be tunable, and other components to transmit and receive digital data for microprocessors 93 and 94 into the optical wired interconnects 99' such as an omniguide using, for example, a specific wavelength of light for each separate channel of each separate microprocessor 93 and 94 utilizing dense wave division multiplexing (DWDM).

FIG. 22B shows an enlargement of the digital signal processor 89' with microlaser 150 with other transmission and reception components.

FIG. 22A shows a simple bus network connection architecture between the interconnect 99' and the microprocessors 93 and 94. However, since the interconnection 99' is optical and the bandwidth available is very broad, the optical connection 99' allows connections between microprocessors 93 and 94 in PC 90₁ that are functionally equivalent to those shown in FIG. 21B, which includes a representation of physical connections. The interconnects between microprocessors 93 and 94 like FIG. 21B are shown within the omniguide 99' shown in FIG. 22A. In fact, the potential bandwidth of the optical interconnect 99' is so great that complete interconnection between all microprocessors 93 and 94 with PC 90₁ is possible, even for a much greater number of microprocessors either in a larger PC 90₁, like FIG. 16T for example, or in other PC 90s, such as PC 90_{2,1}-90_{2,4} and 90_{3,1}-90_{3,16} in FIGS. 20B and 21B connected to PC 90₁ through a network such as the Internet 3, the WWW, or the Grid; consequently, any conventional network structure can be implemented. Consequently, the embodiment shown in FIG. 22A has the flexibility of those of FIGS. 21A and 21B to function in parallel operations like either the FIGS. 20A-20B embodiments or like the FIG. 9 embodiment, depending on the type of parallel operation to be performed, or the FIG. 16 embodiments.

It should be noted that the optical interconnect 99' shown in FIG. 22A can beneficially have a shape other than a thin wire or tube, such as an omniguide with any form or shape located above and connection to microlasers 150 at a suitable location such as on or near the upper surface of the microchip PC 90₁ located at least at, each microprocessor 93 and 94 or connected thereto, for example; the optical interconnect 99' and microlasers 150 and associated transmission and reception components can be located elsewhere on the microchip PC 90₁ with benefit. An omniguide can take a waveform shape or rely exclusively on a mirrored (or semi-mirrored) surface or surfaces (or combination, of both shape and mirrored surface) to guide lightwave signals such as propagated by a microlaser 150 substantially directly and/or by reflection. A relatively large optical interconnect 99' can enable freespace or wireless-like connections between microlasers 150; such an opti-

cal interconnect 99' can cover substantially the entire PC90 microchip or can connect multiple PC90 microchips and can connect one or more PC90 microchips to other PC components.

As shown in FIG. 22A, random access memory (RAM) 66 can be located on microchip PC 90₁ like in FIG. 16U and also can be connected directly or indirectly to the optical interconnect 99' (or use non-optical connections not shown), so that the microprocessors 93 and 94 and RAM 66 can communicate with a very broad bandwidth connection, including with RAM 66 and microprocessors 93 and 94 located off microchip PC 90₁ on the network including the Internet 3 and WWW. Any other component of the PC 90 microchip can be connected with the optical interconnect 99' and more than one such interconnect 99' can be used on the same PC 90 or other microchip. Microlasers 150 can include, for example, 5-to-20-micron-high (or other height) vertical cavity-surface-emitting lasers (VCSELs), which can beam down waveguides built into the PC 90 microchip; alternatively, freespace optics can be employed; and lenses can be employed. Radio-frequency (RF) signals can also be used for similar interconnects 99'. Micro light emitting diodes (LEDs) can substitute for one or some or all of the microlasers 150 and either can be a transceiver (transmit and receive light signals).

FIG. 22C is a side cross section of the microchip PC 90₁ shown in FIG. 22A taken at hatched line 22C (which is abbreviated). FIG. 22C shows the location of the omniguide above the surface of the microprocessors 93 and 94 and RAM 66 and connecting them while also containing two or more microlasers 150 (associated DSP and other components not shown) proximate to each to contain the optical signal generated by the microlasers 150 so that the signal can be transmitted between microprocessors 93 and 94 and RAM 66 either directly or by being reflected off the mirrored (or semi-mirrored) surface of the omniguide 99', for example. Each of the microprocessors 93 and 94 (or 30 or 40) and RAM 66 (or any other memory component such as: L1 cache or L2 cache, for example, or other microchip component) can have one or more microlasers 150 and each such microlaser 150 can distinguish itself from other microlasers 150 on the microchip (or off it) that also generate wavelength signals by using, for example, a distinct wavelength of light for data transmission and/or utilizing wave or dense wave division multiplexing. FIG. 22A is a top view of the microchip PC 90₁, which is a PC system on a microchip, any of which disclosed in this application can be also more generally any microchip with multiple processors. The microlasers 150 (and associated transmission and reception components such as DSP) that are associated with RAM (or parts of it) or other memory components can either provide data in response to direct inquiries or fetches made by a microprocessor 93 or 94 or can broadcast a continual stream of current data (continually updated and repeated in continuous cycle, for example) which is used by the microprocessor as needed.

Any of the embodiments shown in FIGS. 22A, 22B and 22C can be combined with one or more of any of the preceding figures of this application to provide a useful improvement over the art.

FIG. 23A shows multiple firewalls 50, a concept indicated earlier by the at least one firewall 50 discussed in FIG. 17D. FIG. 23A shows a PC1 or microchip 90 with a primary firewall 50 and additional interior, firewalls 50¹, 50², and 50³, that are within primary firewall 50. As shown, interior firewall 50³ is in the most protected position, since it is inside all the other firewalls, while the other interior firewalls 50², and 50¹ are progressively less protected, since, for example, interior firewall 50¹ is protected from the outside network only by the

primary firewall 50. As shown, progressively more protected positions can be created within the PC1 or microchip 90. The interior firewalls can also be arranged in any other way within the primary firewall 50. The interior firewalls can be used to separate user files from system files, for example, or to separate various hardware components from each other. In this manner, a number of compartments can be created within the PC1 or microchip 90 to more safely protect the software, hardware, and firmware of the PC1 or microchip 90, just as ships have a number of separate watertight compartments to protect against flooding and avoid sinking. Any of the primary or interior (or other inner firewalls discussed below) can be hardware, software, or firmware, or a combination, and can coexist in layers, so that a firewall 50, for example, may have a hardware firewall, a software firewall, and a firmware firewall, either as independent units or as integrated components. W³ in FIG. 23A and subsequent Figures denotes the World Wide Web.

FIG. 23B shows another embodiment of compartments created by inner firewalls within a PC1 or microchip 90. Primary firewall 50 and interior firewall 50¹ are like FIG. 23A, but interior firewalls 50², 50³, and 50⁴ are shown perpendicular to firewalls 50 and 50¹ (just to illustrate in a simplified schematic way, which may be different in an actual embodiment). In this way, an upper row of compartments U¹ and U² can be used, for example, to bring from the network files which are first authenticated and then enter into the U¹ compartment, are decrypted, and undergo a security evaluation, such as by virus scan, before transfer to the most secure compartment U². Any operations could potentially occur in any compartment, depending on the level of security desired by the user (by over-ride) for example, but an advantageous default system would allow for files with the highest levels of authentication, encryption, and other security evaluations to be allowed into the most secure compartments.

Similarly, operating system files can also be authenticated and brought from the network side of the PC1 or microchip 90 into compartment O¹ for decryption and security evaluation or other use, and then finally transferred into the most secure compartment O². Again, similarly, a row of compartments can be used for separating hardware, such as a master microprocessor 30 or 93 being located in compartment M¹ and a remote controller 31, for example, located in compartment M².

Also, additional inner firewalls 50²², 50³³, and 50⁴⁴ can be located outside the primary firewall 50, but within the network portion of the PC1 or microchip 90, to separate user files in compartment U from operating system files, in compartment O from hardware such a slave microprocessor in compartment S on the network side. In the example shown, an additional row is shown for hardware, including a hard drive in a compartment BD on the network side, a hard drive in compartment HD¹ on the PC1 or microchip 90 user's side, and flash memory (such as system bios 88) in compartment F². Each microprocessor 30, 40, 93, or 94 can have its own compartment in a manner like that shown in FIG. 23B, as can associated memory or any other hardware component.

FIG. 23C shows, an, inner firewall, 50 embodiment similar to FIG. 23B, but FIG. 23C shows that any file or set of files, such as operating files O or user data files U or application files A, can have its own inner firewall 50^O or 50^U or 50^A. Similarly, any hardware component, such as hard drive HD, also can have its own inner firewall 50^{HD}. Additionally, more than one file or set of files or hardware components can be grouped together within an inner firewall, such as 50^S shown in FIG. 23C.

FIGS. 23D and 23E show operating system files O or application files A like those shown in FIG. 23C, but organized differently in discrete layers, each separate grouping of the operating or application files having a separate firewall 50 (and optionally with as well as a PC1 or PC90 firewall shown in earlier Figures), so that the firewall structure is like that of an onion. The operating system files O or application files A can have a parallel structure, with an innermost kernel operating system or application file located in the center, with additional features in other files in subsequent layers, from the simplest to the most complex and from the most secure and trusted to the least secure and trusted.

Using this structure, as shown in FIG. 23D, an innermost operating system core O¹ may be firmware stored in a read-only memory (ROM), located in a microchip for quick access, so that a simplest version operating system with all core features can be protected absolutely from alteration and can be available almost immediately, without lengthy boot up procedures required by loading the operating system from a hard drive, for example. The core operating system O¹ can include a core of the system BIOS or of the operating system kernel, for example; it would be advantageous for this core to be capable of independent operation, not dependent on components in other levels to operate at the basic core level (similarly, other levels can advantageously be independent of higher levels).

A secondary operating system O² can be software located advantageously on flash or other microchip non-volatile memory such as magnetic (or less advantageously, a hard drive or other mechanical storage media) and can consist of additional features that are more optional, such as those not always used in every session, or features that require updating, changing, or improving, such features coming from trusted, sources located on a network, such as the Internet or the Web; additional portions of or upgrades to the system BIOS and the operating system kernel can be located in O², for example.

A third level operating system O³ located, for example, on a hard drive, can consist of additional software features that are used only occasionally and are more optional, and can be loaded as needed by a user into DRAM or magnetic memory microchip for execution, for example. Operating systems O² and O³ can include, for example, the most recent upgrades from a known and trusted source, such as a commercial software vendor or open source software developer, that are downloaded from a network, including the Internet and the Web, or loaded from conventional memory media like CD or floppy diskette. All three levels of such operating systems O¹, O², and O³ together can constitute, for example, roughly the equivalent of a conventional PC operating system typical in the year 2000.

A fourth level operating system O⁴, for example, can consist of special use or single use operating system add-ons, especially software coming from untrusted or unauthenticated sources on a network, such as the Internet or the Web.

For example, the graphical interface of the operating system can be in 2D only at the O¹ level, in 3D at the O² level, rendering at the O³ level, and animation in the O⁴ level; additionally, a standard format can be maintained in the O¹ and O² levels, with user or vender customization at the O³ level.

As shown in FIG. 23E, application files such as A¹, A², A³, and A⁴ can be structured the same way as operating system files O in FIG. 23D and with the same layered approach to firewalls 50 as in FIG. 23D. Typical application software of the year 2000 can be restructured in this manner.

The kernel operating system files O^1 and O^2 , as well as kernel application files A^1 and A^2 can be located in any personal computer PC1 or PC90, including at the level of an appliance including the simplest device, advantageously in ROM and in non-volatile read/write memory such as Flash (or magnetic such as MRAM, or ovonic memory) microchips, for example, as described in FIGS. 23D and 23E above. Inclusion of wireless connection capability is advantageous, as is the use of DWDM.

An advantage of the file and firewall structures shown in FIGS. 23D and 23E is that a system crash or file corruption should never occur at the simple and unalterable level O^1 or A^1 and any level above O^1 or A^1 can be recovered at a lower level, specifically the highest level at which there is a stable system or uncorrupted data. For example, a word processing application program can have the most basic functions of a typewriter (i.e. storing alphanumeric, punctuation; spacing, and paragraph structure data) stored on a ROM microchip in A^1 and related user files (i.e. such as a word document) on U^2 . Insertion of a digital video file into a word document can be handled at the A^3 level and insertion of a downloaded special effect at the A^4 level. In this example, a crash caused by the insertion at the least secure and most complex A^4 level would not disturb the word document located at the U^2 or U^3 level. Rebooting and/or recovery can be automatic when detected by the operating system or at the option of the user.

Thus, FIGS. 23A-23E illustrate embodiments wherein a PC1 or microchip 90 includes a hierarchy of firewalls. In the context of the present invention, firewalls may be structured to allow varying degrees of access from the network side of PC1 or microchip 90. As discussed above, ROM may totally deny access from the network side, effectively creating an innermost firewall. Hardware, software, firmware, or combinations thereof may be structured to deny or allow a predetermined maximum level of access from the network side, effectively creating outer firewalls. Similarly, intermediate firewalls effectively may be created.

The embodiments of FIGS. 23A-23E, as well as earlier FIGS. 17A-17D and earlier embodiments, provide a solution to digital rights management by providing a highly safe environment for the owners of digital versions of audio, video, and software copyrighted material. Such copyrighted material as movies, television, music, and application or operating system software may be decrypted and controlled on the network user side of the PC 1 or PC 90, while the PC 1 user is denied access to the decrypted digital version of the copyrighted material. However, the network user can make the material viewable to the PC 1 user, but not copyable, via the PC 1 and PC 90 microchip architecture shown in FIGS. 10A and 10C. For example, a copyrighted movie or music album may be a file that is associated with control and other software; all files located on one or more specific hardware components may be grouped together within an inner firewall, such as 50⁵ shown in FIG. 23C.

Additional security for copyright owners may be provided by using a digital signal processor (DSP), and/or analog and/or other components grouped within the inner firewall 50⁵ to convert network user selected decrypted digital files into analog files before they are transmitted off the PC 90 microchip, so that only an analog signal exits the PC 90 microchip for viewing or listening by the PC 1 user. As such, direct digital copying by the PC 1 user of copyrighted digital files provided over the Internet, is prevented.

Any of the embodiments shown in FIGS. 23A-23E can be combined with one or more of any of the preceding figures of this application to provide a useful improvement over the art.

Additionally, an inner firewall can divide any hardware component into a separate network side compartment and a separate firewall protected side compartment. For example, a hard drive 61 can have a controller 61' that is divided into two compartments, HD and HD¹, as above. As shown in FIG. 24, the user side HD¹ compartment of the controller 61' can have a read capability controller r and a write capability controller w, while the network side HD compartment can be limited to a read capability controller r only. The user side HD¹ compartment controller can be, for example, used to control only the upper surface of the hard drive 61 platters, while the network side HD compartment controller can be used to control only the lower surface of the hard drive 61 platters, so that a single hard drive can effectively serve a dual role as both a network-accessible hard drive and a user-accessible hard drive, while maintaining a firewall 50 between them. Additionally, the network side HD controller can optionally have a write capability also, which can be preemptively turned on or off by the PC1 or microchip 90 user. Other relative allocations between network and user of the HD 61 platters can be made and can be configurable by the user or system administrator or not configurable.

Similarly, CD drives 63 or DVD drives 64 (read only or read/write) can have a controller 63' or 64' like that of the HD controller 61' above that is divided by a firewall 50, so that some laser beams are under network control and other laser beams are under user control, like the above hard drives. Floppy disk drives, "Zip" drives, and other removable disk or diskette drives can similarly be divided by a firewall 50 so that there is a physical user portion of the disk or diskette and a physical network portion of the disk or diskette, both either fixed or configurable by a user or system administrator or other authorized source. Memory microchips such as RAM or Flash or other can also be divided into network and user sides in a similar manner.

Any of the embodiments shown in FIG. 24 can be combined with one or more of any of the preceding figures of this application to provide a useful improvement over the art.

The use of volatile memory on the network side of the PC1 or microchip 90 is particularly useful in eliminating viruses and other security problems originating from the network side, such as malicious hackers on the Internet. When the network side of the firewall 50 of the PC1 or microchip 90 is returned to its user (preemptively or otherwise), volatile memory like random access memory (RAM) such as DRAM, on the network side can first be erased. For example, volatile memory can be purged by momentarily interrupting power to the network side of the PC1 or microchip 90, thereby erasing all network data so that no network data is retained when the user regains control of the network side of the PC1 or microchip 90 for the user's use, except at the user's option; other conventional means may be employed. Of course, when the user is specifically using the network side, for example, for Web browsing, the operating system or the user can selectively save network side files or transfer them to the user side.

On the network side, non-volatile memory like Flash, MRAM, and ovonic memory with network data must be overwritten to obtain the same erasure-type protection, which can be a disadvantage if it takes much more time. Moreover, for relatively large storage media, such as CD-RW or DVD-RW with write-once capability, network data writing must be tracked to be effectively erased. Any new network file on non-volatile memory with only a write-once capability can be erased by overwriting all "0's" to "1's", so that, for example, the network data written on a CD-RW or DVD-RW would be converted to all "1's" or "pits" (no unpitted writing surface within the network data sector, permanently overwriting the

file); optionally, the operating system or the user can selectively save network side files or transfer them to the user side, or vice versa. There is a disadvantage to using Flash memory, since repeated overwriting will eventually degrade it.

FIGS. 25A-25D show the use for security of power interruption or data overwrite of volatile memory like DRAM and non-volatile memory like Flash or MRAM (or ovonics), respectively, of the network portion (N) of a personal computer PC1 or system on a microchip PC90; the network (N) portion being created within a PC1 or PC90 by a firewall 50 (as described above in previous figures) and including resources that, when idled by a user, can be used by the network, including the Internet (I) or the World Wide Web. Such use is to prevent the unplanned or approved mixture of user and network files by either files being retained in the "swing space" (N) during the transition from use by a network user to use by the PC1/PC90 user or vice versa.

As shown in FIG. 25A and FIG. 25C, when the network portion (N) of the PC1 personal computer or PC90 microchip is idled by a user, for example, power is interrupted to volatile memory like DRAM and/or data is overwritten to files in non-volatile memory like Flash or MRAM (or ovonics), so that no files exist in the network portion (N) after such interruption or overwriting.

After the step shown in FIGS. 25A and 25C, the network portion (N) can be used safely from a security viewpoint by a user from the network, including the Internet and the World Wide Web (and potentially including other network resources), as shown in FIG. 25B, or by the PC1/PC90 user, as shown in FIG. 25D, potentially including other resources from the user portion (U) of the PC1 or PC90. As noted earlier, the FIG. 25 approach can advantageously be used as an additional feature to other conventional security measures.

Any of the embodiments shown in FIGS. 25A-25D can be combined with one or more of any of the preceding figures of this application to provide a useful improvement over the art.

The PC 90 microchip as previously described, or a personal computer PC 1 (or any microchip, including a special or general purpose microprocessor on a microchip, alone or including one or more other system components as previously described) may include one or more photovoltaic cells 201, as are well known in the art. The photovoltaic cells 201 may be located on the PC 90 microchip or located near the PC 90 microchip, such as adjoining it or adjacent to it, or located less near, such as in the PC 90 microchip user's home, office, or vehicle, either inside or outside, or may be located more remotely.

FIG. 26A shows one or more photovoltaic cells 201 located on a PC 90 microchip. The photovoltaic cells 201 may use electromagnetic radiation, such as visible light, as a power source that is directed to the cells 201 by an optical waveguide 202, which may include a size that is sufficient to allow the cells 201 to generate electrical power at maximum output level or at a most efficient level. In addition, visible light in freespace (without a waveguide 202) may also serve as a power source and can be directed by the use of one or more lenses 204.

FIG. 26B shows a single microchip 200 including both a PC 90 and one or more photovoltaic cells 201. FIG. 26B shows a top view of a multi-layer microchip having one or more photovoltaic cells 201 on one side of a microchip 200, with a PC 90 on the other side of the microchip 200, as shown in FIG. 26C in a bottom view of the same microchip as FIG. 26B. Besides being integrated on the same microchip 200, the photovoltaic cells 201 may be located separately from the PC 90 microchip, and the two separate elements may be joined or adjoining.

A light source for the photovoltaic cells 201 can be direct or indirect and can be sunlight or artificial light, including light from a laser, or a combination, and can be optionally focused by a lens 204. The light may be coherent with one or more discrete frequencies, such as from a laser, or incoherent with many frequencies. The artificial light may be generated by well known conventional means that are conventionally powered by electricity distributed by the existing electrical power grid, as is well known in the art.

A single photovoltaic cell or a number of cells 201 may power each component on the PC 90 microchip, such as the master microprocessor 93 or slave microprocessors 94, DRAM or MRAM, Flash memory, DSP, or laser 150, or any of the other components previously described. The photovoltaic cells 201 may be connected to one or more batteries. The photovoltaic cells 201 can be located remotely as a separate unit, such as on the PC 90 microchip user's roof at home, car, or office, so that the cells 201 provide general local power or power dedicated to the PC 90 microchip and/or associated components. The PC 90 microchip may be a network server, router, or switch, so that any network component can be powered by photovoltaic cells 201, including the Internet, an Intranet, or the World Wide Web.

The FIG. 26A-26C embodiments advantageously eliminate the need for a microchip, such as the PC 90 microchip, to have a wired connection 99 that typically provides power or data or both, but which also provides a connection means for the entry of electromagnetic flux, which can impair or destroy the functioning of the PC 90 microchip. The embodiments shown rely on light, which does not transmit electromagnetic flux, for power and data.

FIG. 27A shows a single microchip 200, combining a PC 90 microchip (or any microchip, including a special or general purpose microprocessor on a microchip, alone, or including one or more other system components as previously described) and one or more photovoltaic cells 201, that is substantially surrounded by a Faraday Cage 300, such as is well known in the art, that is optimized to shield against magnetic flux, including high frequency flux (and may include shielding against electric flux). Faraday Cage 300 may be constructed of a mesh structure, or may also be a continuous structure without holes, which has an advantage of preventing entry by very high frequency electromagnetic flux, and may incorporate other microchip structures, such as a heat sink 301.

FIG. 27B shows separate PC 90 microchip and one or more photovoltaic cells 201; the two separate components are connected by a wire 99, and all three components are substantially surrounded by a Faraday Cage 300, also known as a Faraday Shield or Screen.

FIG. 27C shows the same components as FIG. 27B, but shows each component substantially surrounded by a separate Faraday Cage 300, all of which may be connected. For portable handheld wireless devices, the ground for the Faraday Cage 300 may be the user's body.

As shown in FIG. 27B, the PC 90 microchip may be located in a housing for any of the PC's described previously, such as a case of a laptop personal computer 401 or a PC cell phone 402, which may also have a separate Faraday Cage 300, so that the PC 90 microchip is substantially surrounded by more than one Faraday Cage 300. The inner Faraday Cage 300 surrounding the PC 90 microchip may be optimized to shield against specific frequencies of magnetic flux, such as high frequency flux in the microwave range, which may be assisted by the relatively smaller size of the PC 90 microchip (compared to its housing). FIG. 27D shows an inner Faraday Cage

300 surrounding only a portion, the PC **90**, of a microchip such as the combined microchip **200**.

As shown in FIGS. **27E** and **27F**, the PC **90** microchip can be separate from the photovoltaic cell or cells **201** and can be joined by a wired connection **99**.

As shown in FIG. **27E**, an inner Faraday Cage **300** may surround only a portion of a PC **90** microchip, such as a Magnetic Random Access Memory (MRAM) component.

FIG. **27F** shows Faraday Cage **300** that surrounds only a portion of one or more photovoltaic cells **201**, such as a part conducting an electrical current flow directly to the PC **90** microchip.

The PC **90** microchip may also be powered by one or more fuel cells **211** or one or more batteries (each with one or more cells) **221** or any combination of such batteries **221**, fuel cells **211**, or photovoltaic cells **201**. As shown in FIGS. **27E** and **27F**, the PC **90** microchip is typically separate from a fuel cell or cells **211** or batteries **221** and can be joined by a wired connection **99**, as shown, as is the case with a photovoltaic cell or cells **201**. A wired connection **99** can be configured to protect the PC **90** microchip from electromagnetic flux through the use of RF traps or Ferrite grommets or beads **212** on the wire or cable connection **99**.

By providing power without an external wired connection **99**, both fuel cells **211** and batteries **221** isolate the PC **90** microchip from a power grid that can transmit electromagnetic flux, but to do so a battery or batteries **221** can be configured to provide connection to the power grid only intermittently when charging is required.

FIG. **27G** shows a microchip, such as a PC **90** microchip, surrounded by a Faraday Cage **300** but without including a photovoltaic cell **201** shown in FIGS. **27A-27F**.

FIG. **27H** shows a PC housing such as a laptop PC **401** or PC cell phone **402** including a PC **90** microchip and separate Faraday Cages **300** surrounding both the microchip and housing. Also shown is an antenna **499** (or antennas) for wireless communication that can be separated from the Faraday Cage **300** to protect the electrical components of the PC by an RF trap or Ferrite grommets or beads **212**. The antenna **499** can project externally from the PC housing or be located internally in the PC housing, such as in the screen housing of a laptop PC **401**. In an exemplary implementation, the antenna **499** is located outside of at least one Faraday Cage **300**.

Any of the embodiments shown in FIGS. **26A-26C** and **27A-27H** may be combined with one or more other embodiments shown in those figures or in preceding FIGS. **1-25** and described herein.

FIG. **28** shows a silicon wafer **500** used to make microchips. The largest wafers **500** in current use are 300 mm (12 inches) in diameter and can contain as many as 13 billion transistors. Current state of the art in microchip fabrication is 0.13 micron process technology and the next process will be measured in nanometers (90 nm). As shown in FIG. **28**, microchips **501** are separated by an edge portion **502**. A microchip **501** can be a PC **90** microchip.

FIG. **29A** shows a top view of a microchip **501** surrounded by adjoining portions of adjoining microchips **501** in a section of the silicon wafer **500**. The microchip **501** is bounded by edge portions **502**. Although the current state of the art in microchip fabrication on a silicon wafer is to use only one process on a wafer, embodiments of the invention use two or more fabrication processes on a single wafer **500**.

As shown in the example of FIG. **29A**, one process can be located on one section **511** on the microchip **501**, while a second process can be located on a second section **521** of the microchip **501**. A third process can be located on a third

section **531** of the microchip **501**; additional processes can also be located on other sections of the microchip **501**.

The processes can be completely separate while at least sharing the common silicon wafer **500** base, and the processes can occur at different fabrication facilities, including those owned by different manufacturers. Alternatively, two or more separate processes may have common sub-processes that can be integrated, i.e., performed at the same time. Sections of the microchip **501** that are not undergoing a process can be protected from that process by a protective coating that is unaffected by that process and removed after that process. There can be one or more temporary protective coatings, which can remain on for more than one process.

The separate sections of the separate fabrication processes of the microchip **501** can be in any shape or pattern of the microchip. As shown in the FIG. **29A** example, one or more separate processes can be located on adjoining portions of adjoining, microchips. For example, as shown in FIG. **29A**, section **521** is located on the lower portion of one row of microchips **501** and on the upper portion of the adjoining row of microchips **501**, which would be positioned upside down of the wafer **500**, so that the contiguous area of the section **521** process is maximized. Similarly, section **531** is shown in the example located on the lower portion of the adjoining row of microchips **501** and on the upper portion of the middle row of microchips **501**. Alternatively, all of the microchips **501** of the wafer **500** can be positioned upright on the wafer.

Embodiments of the invention include any fabrication process of a silicon wafer **500** and can include wafers made of other materials suitable for microelectronic devices, such as gallium arsenide. The fabrication processes in current widespread use are generally CMOS (complementary metal-oxide semiconductor), but can be bipolar or other. The separate processes (and separate sections **511**, **521**, and **531** shown in FIG. **29A**) can be for general purpose microprocessor (including one or more cores), memory (DRAM or non-volatile such as Flash or MRAM or ovonic), analog (including radio and/or laser), digital signal processing (DSP), micro-electro-mechanical system (MEMS), field programmable gate arrays (FPGA), graphic processing unit (GPU), microprocessor chipset, and others.

Embodiments of the invention facilitate a "system on a chip" (SoC), such as the earlier described PC **90** microchip, by allowing most or all of the micro components of a PC to be located on a single microchip. Even the consolidation of only two microchips into a single microchip provides a significant increase in processing speed and reduced power consumption. The silicon die becomes the motherboard for all the micro components of the PC, leaving only the macro components like battery, power supply, and input/output (I/O) connections to be located on the printed circuit motherboard. The result is ultra-large-scale-integration.

FIG. **29B** shows a top view of the microchip **501** embodiment of FIG. **29A** after the die has been separated from the silicon wafer **500** and positioned in a microchip package **503**.

The fabrication processes illustrated in FIGS. **29A-29B** can include material such as silicon germanium, gallium arsenide, indium phosphide and others used, for example, as deposits on silicon. Besides using different materials in different sections of the microchip, different size processes can be used in different microchip sections, such as a 0.13 micron process on section **511** and a 0.18 micron process on section **521** in the FIG. **29A** example. All or parts of the microchip **501** can be synchronous or asynchronous. Both different size and different material processes can be combined on different sections of the microchip **501**.

Although the maximum increase in speed and decrease in power consumption can be achieved by putting all micro or nano components on a single “system on a chip,” such as for a PC, even a minimal combination of just two different micro or nano components of a single microchip **501** can yield a very significant increase in speed and decrease in power consumption. To take a very simple example, a silicon wafer **500** can have 256 MB of DRAM manufactured onto a section **531** of the microchips **502** located on the wafer by one factory; when that DRAM process is completed, a second factory can add a general purpose CPU like a Pentium 4 to a second section **511** of the microchips **501** on the silicon wafer **500**. Such an approach allows direct communication between microprocessor and DRAM on the microchip **501** for much greater speed and reduced power. Since 256 MB DRAM is an inexpensive commodity product currently, especially if purchased as wafers **500**, there would be little or no increase in the production time of the microprocessor.

FIG. **30A** illustrates an embodiment of the invention, which is an alternative method of uniting separate fabrication processes on the same microchip **501**. Sections **501¹**, **501²**, and **501³** of FIG. **30A** correspond to sections **511**, **521**, and **531** of FIGS. **29A** & **29B** in that both sets of sections represent three separate processes, but in FIG. **30A** each section is a separate die cut from a wafer **500** and all three sections are united in a single package **503**. The section dies **501¹**, **501²**, and **501³** can be held together by the chip package **503** or can be glued together, or a combination of the two in parts or the whole. In addition, the section dies can be assembled into a chip package **503** or the package can be assembled around the dies or a combination of both partially or completely.

The separate process dies illustrated in the FIG. **30A** example may be assembled with the surface that the process is on in each die being substantially level with each other, so that both process surfaces of the dies form a plane that is substantially flat. The edges of the dies are configured so adjoining dies fit together as closely as possible, as shown in FIG. **30A** at **502²** and **502³**.

The circuits of dies **501¹**, **501²**, and **501³** are connected at their edges **502²** and **502³** by interconnect lines **580** that can be widened as shown in **581** of FIG. **30B**, which shows a portion of die edge **502³** and **502²** in an enlarged view. A process can be added in the area **591** overlapping the edges of the dies at **502³** and **502²** bounded by lines **590**; in that process interconnect lines **580** of the two separate dies can be connected by laying down connections at **582** that connect to the enlarged portions **581** of the interconnect lines **580**, as illustrated in FIG. **30B**.

FIG. **30C** shows that the die edges **502³** and **502²** can have any shape or pattern, not just a straight line shown above in FIGS. **30A** & **30B**.

FIG. **31** shows a combination of the embodiments shown in FIGS. **29** and **30**. Microchip **501** as shown in FIG. **29** is shown assembled with separate dies **501¹**, **501²**, and **501³** into a microchip package **503**, with edges between dies at **502¹**, **502²**, **502³**, and **502²³**, which could include a connection process such as the example shown in FIG. **30B**.

The microchip **501** dies shown in FIGS. **29-31** can be packaged using FCPGA (flip-chip pin grid array), FCBGA (flip-chip ball grid array), BBUL (bumpless build-up layer) or other technology.

Any of the embodiments shown in FIGS. **28**, **29A-29B**, **30A-30C**, and **31** can be combined with one or more other embodiments shown in those figures or in the preceding FIGS. **1-27** and described herein.

It is currently contemplated that commercial embodiments of the networks, computers, and other components of the

Internet, World Wide Web, and the Grid (or MetaInternet) described in this application in preceding figures, including hardware, software, firmware, and associated infrastructure will be developed in conjunction and with the assistance of the Internet Society (ISOC), the World Wide Web Consortium (W3C), the Next Generation Internet (NGI), professional organizations like the Institute of Electrical and Electronics Engineers (IEEE) and the American National Standards Institute (ANSI), as well as other national and international organizations, and industry consortia drawn from the telecommunication, T.V. cable, ISP, network, computer, and software industries, as well as university and other research organizations, both U.S. and international, to set agreed upon operating standards which, although often arbitrary, are critical to efficient, reliable functioning of the Grid (or MetaInternet).

It is also presently contemplated that the Linux programming language will take a central role in the Grid (or MetaInternet), since a homogeneous system has an advantage as being most efficient and effective, and Linux is among the most stable, efficient higher level software available, one that has already established a preeminent role in distributed parallel processing. A heterogeneous Grid (or MetaInternet) is certainly feasible too, but less advantageous, as is the Java programming language, which excels in heterogeneous environments. Although Linux may be employed instead of Java in keeping with the more effective homogeneous approach for parallel processing systems that can scale even to the massive numbers of PCs available on the Internet and WWW, either Java or principles employed in Java may be used with benefit, especially in certain cases like security, such as the use of “sandboxes” to provide secure execution environments for downloaded code (see page 39 of *The Grid*, Foster and Kesselman and associated bibliography references **238**, **559**, **555**, and **370**), although use of one or more internal firewalls as discussed earlier in FIGS. **10** and **17** to protect personal user files and critical hardware and software systems, such as the operating system, may provide similar capability.

It is also contemplated currently that, like the Linux programming language, the Grid (or MetaInternet) described in this application can be developed into a commercial form using open source principles for Internet-like standards for software and hardware connections and other components. Such open source development is anticipated to be exceptionally successful, like Linux, because much of it can be free-ware, although modified with one vital enhancement to provide equity for significant contributors: minimal licensing fees that are to be paid only by medium to large commercial and governmental entities at progressive rates based on financial size; the resulting funding can be used for significant financial and other awards for special research and development efforts relating to the Grid (or MetaInternet) and its open source development, particularly outstanding achievements by individuals and teams, especially independent developers and virtual teams, the awards also being progressive in terms of importance of contribution and most being peer-selected. Open source commercial development of the Grid (or MetaInternet) should therefore, like Linux, attract the most interested and best qualified technical expertise on the planet, all linked by the Internet and WWW to collaborate virtually in realtime 24 hours a day and 7 days a week, creating, a virtual entity extraordinarily skilled in the existing art.

It is also anticipated that the exclusive rights to the Grid (or MetaInternet) granted by patents issued on this application, particularly for the homogeneous embodiment of the Grid (or MetaInternet)—which is by far the most effective and efficient form—will ensure that the Grid (or MetaInternet) is homogeneous on critical hardware and software standards

and protocols. That is because any heterogeneous systems cannot compete commercially due to inherent inferiority in efficiency, while any competing homogeneous system would infringe the patents issuing from this and other applications and therefore be enjoined from operations. The open Grid (or MetaInternet) standards would thus be patent-protected.

As noted earlier, the Internet 3 and WWW (and successors or equivalents) are expected to ensure that any single design standard in widespread use, such as the Wintel standard (software/hardware) and the Apple Macintosh standard (also both), are homogeneous as to Grid (or MetaInternet) parallel processing systems as outlined in this application, since the Internet and WWW and equivalents or successors make available such a large pool of homogeneous computers with the same standard, in ever increasingly close proximity as more and more PCs and other devices go online. The increasingly universal connection attribute of the Internet 3 and WWW and, successors therefore create virtual homogeneity for most significant brands.

The term homogeneous as it is used here refers to functional design standards primarily, not physical structure, for example, when applied to hardware. In this sense, then, for example, the Intel Pentium II, the Advanced Micro Devices (AMD) K6-6, and the Cyrix MII microprocessor chips are functionally compatible and homogeneous with no need for special emulation software, although they are each structurally quite different and use different microcode at the microchip level. The new Transmeta microprocessors are expected to be functionally compatible and homogeneous through elaborate and highly efficient emulation, potentially an ideal microprocessor for the Grid (or MetaInternet). In contrast, for example, the Apple G3 processor is also structurally different but in addition requires a different operating system and is therefore not functionally compatible and not homogeneous with the Pentium. K6-6, and MII microprocessors discussed above. Similarly, MS DOS and DR DOS are functionally compatible software PC operating systems and homogeneous, even though their codes are different, whereas Apple Macintosh operating systems are not functionally compatible or homogeneous with the two DOS systems, except with the addition of special emulation software, which is not efficient. Substantially interchangeable use therefore is a defining element of homogeneity as used in this application. An example of a heterogeneous parallel processing system distributed among many computers, which can be of any sort, is the University of Virginia's Legion system, in contrast to the homogeneous systems discussed above.

This application encompasses all new apparatus and methods required to operate the above described network computer system or systems, including any associated computer or network hardware, software, or firmware (or other component), both apparatus and methods, specifically included, but not limited to (in their present or future forms, equivalents, or successors): all enabling PC and network software, hardware, and firmware operating systems, user interfaces and application programs; all enabling PC and network hardware design and system architecture, including all PC and other computers, network computers such as servers, microprocessors, nodes, gateways, bridges, routers, switches, and all other components; all enabling, financial and legal transactions, arrangements and entities for network providers, PC users, and/or others, including purchase and sale of any items or services on the network or any other interactions or transactions between any such buyers and sellers; and all services by third parties, including to select, procure, set up, implement,

integrate, operate and perform maintenance, for any or all parts of the foregoing for PC users, network providers, and/or others.

The combinations of the many elements of the applicant's invention introduced in the preceding figures are shown because those embodiments are considered to be at least among the most useful possible, but many other useful, combination embodiments exist but are not shown simply because of the impossibility of showing them all while maintaining a reasonable brevity in an unavoidably long description caused by the inherently highly interconnected nature of the inventions shown herein, which generally can operate all as part of one system or independently.

Therefore, any combination that is not explicitly described above is definitely implicit in the overall, invention of this application and, consequently, any part of any of the preceding. Figures and/or associated textual description can be combined with any part of any one or more other of the Figures and/or associated textual description of this application to create new and useful improvements over the existing art.

In addition, any unique new part of any of the preceding Figures and/or associated textual description can be considered by itself alone as an individual improvement over the existing art.

The foregoing embodiments meet the overall objectives of this invention as summarized above. However, it will be clearly understood by those skilled in the art that the foregoing description has been made in terms only of the most preferred specific embodiments. Therefore, many other changes and modifications clearly and easily can be made that are also useful improvements and definitely outside the existing art without departing from the scope of the present invention, indeed which remain within its very broad overall scope, and which invention is to be defined over the existing art by the appended claims.

The invention claimed is:

1. A microchip for a computer configured to connect to at least one network of computers, said microchip comprising:
 - at least a first internal hardware-based firewall, said first internal hardware-based firewall configured to deny access to at least a portion of said microchip from said network;
 - at least one general purpose microprocessor including at least two general purpose cores or general purpose processing units; and
 - at least one memory component located inside of at least a second internal hardware-based firewall that is located between said memory component and at least one said core or processing unit with which said memory component is associated; and wherein
 - at least a first said core or processing unit is located within said first portion of said microchip that is protected by at least said first internal hardware-based firewall;
 - at least a second said core or processing unit is located within a second portion of said microchip that is not protected by at least said first internal hardware-based firewall; and
 - at least said second core or processing unit is separated from said first core or processing unit by at least said first internal hardware-based firewall and is located between at least said first internal hardware-based firewall and said at least one network of computers.
2. The microchip of claim 1, wherein said microchip is surrounded by at least one Faraday Cage.
3. The microchip of claim 2, wherein said microchip includes a plurality of Faraday Cages.

57

4. The microchip of claim 1, wherein said microchip includes at least three or more said cores or processing units, each located within a portion of said microchip protected by at least one internal hardware-based firewall.

5. The microchip of claim 1, wherein said microchip includes a plurality of dies, at least two of said dies having been made by a separate fabrication process and assembled into a package with separate die sections connected directly.

6. The microchip of claim 1, wherein at least one control unit is located inside of at least one of said internal hardware-based firewalls and said at least one control unit controls said cores or processing units.

7. The microchip of claim 1, wherein said microchip includes at least three or more said cores or processing units, at least two said cores or processing units being located inside of at least one said internal hardware-based firewall.

8. The microchip of claim 1, wherein said second core or processing unit is located inside of at least a third internal hardware firewall.

9. A microchip for a computer configured to connect to at least one network of computers, said microchip comprising: at least four internal hardware-based firewalls, said internal hardware-based firewalls configured to deny access to at least four portions of said microchip from said network; at least one general purpose microprocessor with at least four general purpose cores or general purpose processing units;

at least three of said cores or said processing units are each located within one said portion of said microchip that is protected by at least one of three separate internal hardware-based firewalls; and

at least a fourth said core or said processing unit is located within a portion of said microchip that is not protected by at least said three separate internal hardware-based firewalls, at least said fourth core or processing unit is separated from said first core or processing unit by at least said three separate internal hardware-based firewalls and is located between said three separate internal hardware-based firewalls and said at least one network of computers; and;

at least one memory component located within a portion of said microchip that is protected by at least said fourth separate internal hardware-based firewall that is located between said memory component and at least one said core or processing unit with which said memory component is associated.

10. The microchip of claim 9, wherein said microchip is surrounded by at least one Faraday Cage.

11. The microchip of claim 10, wherein said microchip includes a plurality of Faraday Cages.

12. The microchip of claim 9, wherein said microchip includes a plurality of dies, at least two of said dies having been made by a separate fabrication process and assembled into a package with separate die sections connected directly.

13. The microchip of claim 9, wherein at least one control unit is located within one said portion of said microchip that

58

is protected by at least one of said three separate internal hardware-based firewalls, and said at least one control unit controls said cores or processing units.

14. A microchip for a computer configured to connect to at least one network of computers, said microchip comprising: at least a first internal hardware-based firewall, said first internal hardware-based firewall configured to deny access to at least a portion of said microchip from said network;

at least one general purpose microprocessor with at least one control unit and at least two general purpose cores or general purpose processing units, said control unit being configured to control said at least two cores or processing units; and

at least one memory component located within a portion of said microchip that is protected by at least a second internal hardware-based firewall that is located between said memory component and at least one said core or processing unit with which said memory component is associated; and wherein

at least said control unit and a first said core or processing unit is located within a portion of said microchip that is protected by at least said first internal hardware-based firewall;

at least a second said core or processing unit is located within a portion of said microchip that is not protected by at least said first internal hardware-based firewall; and

at least said second core or processing unit is separated from said first core or processing unit by said first internal hardware-based firewall and is located between said first internal hardware-based firewall and said at least one network of computers.

15. The microchip of claim 14, wherein said microchip is surrounded by a plurality of Faraday Cages.

16. The microchip of claim 14, wherein said microchip includes three or more internal hardware-based firewalls.

17. The microchip of claim 14, wherein said microchip includes a plurality of dies, at least two of said dies having been made by a separate fabrication process and assembled into a package with separate die sections connected directly.

18. The microchip of claim 14, where said microchip is surrounded by a Faraday cage.

19. The microchip of claim 14, wherein said microchip includes at least three or more said cores or processing units, each located within a portion of said microchip that is protected by at least one said internal hardware-based firewall.

20. The microchip of claim 14, wherein said microchip includes at least three or more said cores or processing units, at least two said cores or processing units being located within a portion of said microchip that is protected by at least one said internal hardware-based firewall.

21. The microchip of claim 14, wherein said second core or processing unit is located within a portion of said microchip that is protected by at least a third internal hardware firewall.

* * * * *

UNITED STATES PATENT AND TRADEMARK OFFICE
CERTIFICATE OF CORRECTION

PATENT NO. : 8,312,529 B2
APPLICATION NO. : 13/283274
DATED : November 13, 2012
INVENTOR(S) : Frampton E. Ellis

Page 1 of 1

It is certified that error appears in the above-identified patent and that said Letters Patent is hereby corrected as shown below:

Title Page;

Section 60, add --Application No. 09/935,779 is a Continuation In Part of Application No. 09/315,026-- to the Related U.S. Application Data, column 1, in line 10, after 7,035,906;

Section 60, column 1, line 13, the reference to --"Patent No. 7,635,529"-- should read --Patent No. 7,634,529--.

Signed and Sealed this
Seventh Day of May, 2013



Teresa Stanek Rea
Acting Director of the United States Patent and Trademark Office